

Stock Code  
6206

***FLYTECH***

**2020**

**ANNUAL REPORT**

Taiwan Stock Exchange Market Observation Post System

<https://mops.twse.com.tw>

2020 Annual Report is available at <http://www.flytech.com>

Printed on April 30th, 2021

**Spokesperson**

Name: Shyu Jia Horng  
Title: President  
Tel: 886-2-87914988  
E-mail: publicrelationship@flytech.com.tw

**Deputy Spokesperson**

Name: Tseng En Chi  
Title: Senior Executive Head on Investment  
Relationship and Legal Affairs  
Tel: 886-2-87914988#6206  
E-mail: publicrelationship@flytech.com.tw

**Stock Agency**

Capital Securities Corp.  
Address: B1F-1, No.97, Sec.2, Dunhua S. Rd., Da'an Dist., Taipei City 10601, Taiwan, R.O.C.  
Tel: 886-2-2702-3999  
Website: <http://www.capital.com.tw>

**Independent Auditors**

KPMG  
Auditors: Wei Ming Shih, Yung-Sheng Wang  
Address: 68F, No.7, Sec.5, Xinyi Rd., Taipei City, Taiwan, R.O.C.  
Tel.: 886-2-8101-6666  
Website: <http://www.kpmg.com.tw>

**Overseas Securities Exchange**

N.A

**Corporate Website**

<http://www.flytech.com>

**Headquarters and Plant****Headquarters**

Address: No.168, Sing-ai Rd., NeiHu District, Taipei City 11494, Taiwan, R.O.C.  
Tel: 886-2- 87914988

**Plant**

Address: No.36, Huaya 3<sup>rd</sup> Rd., Guishan District, Taoyuan City 33383, Taiwan, R.O.C.  
Tel: 886-3-2729688

## Contents

|   |     |
|---|-----|
| I. Report for Shareholders .....  | 1   |
| II. Company Profile .....   | 3   |
| III. Corporate Governance Report .....  | 9   |
| 3.1 Organization.....   | 9   |
| 3.2 Directors and Management Team .....   | 11  |
| 3.3 Implementation of Corporate Governance.....   | 20  |
| 3.4 Information Regarding the Company's Audit Fee and Independence .....  | 68  |
| 3.5 Replacement of CPA:.....  | 69  |
| 3.6 The Company's Chairman, Chief Executive Officer, Chief Financial Officer, and managers<br>in charge of its finance and accounting operations did not hold any positions in the<br>Company's independent auditing firm or its affiliates during 2018. ....   | 69  |
| 3.7 Transfer of shareholder equity transfer and equity pledge by directors, managerial officers<br>and key shareholders holding more than 10% in 2019 and as of the date of publication of the<br>Annual Report. ....   | 69  |
| 3.8 Relationship among the Top Ten Shareholders.....  | 71  |
| 3.9 Ownership of Shares in Affiliated Enterprises.....  | 72  |
| IV. Funding Status .....  | 73  |
| 4.1 Capital stock and stock shares .....  | 73  |
| 4.2 Execution status of issuing corporate bonds.....  | 81  |
| 4.3 Issuance of preferred shares .....  | 81  |
| 4.4 Disclosure relating to depository receipts.....   | 81  |
| 4.5 Status of employee stock certificates.....  | 81  |
| 4.6 The new shares from restricted employee stock option.....   | 81  |
| 4.7 Disclosure on new shares issued in exchange of other company shares .....   | 81  |
| 4.8 Progress on the use of funds.....   | 81  |
| V. Operation overview.....  | 82  |
| 5.1. Business content .....   | 82  |
| 5.2. Market and production and sales overview .....   | 97  |
| 5.3 Number of employees in the last 2 years to the date this report was printed.....  | 107 |
| 5.4 Environmental expenditure information.....  | 108 |
| 5.5 Labor-Management Relations .....  | 110 |
| 5.6 Important contracts: None. ....   | 114 |
| 5.7 Licensing and certification of personnel related to financial transparency by the competent<br>authority.....   | 114 |
| 5.8 Employee Code of Conduct and Ethical Corporate Management Best Practice Principles  | 114 |
| 5.9 Procedure for handling internal information in materiality.....   | 115 |
| 5.10 Work environment and the protection of labor safety.....   | 115 |
| VI. Financial summary .....   | 117 |
| 6.1 Condensed balance sheet, comprehensive income statement, name of the CPAs, and their<br>auditing opinions within the last five years .....  | 117 |
| 6.2 Financial analysis for the latest 5 years .....   | 122 |
| 6.3 Audit report on the most recent year financial statements by the supervisor or the audit<br>committee: .....  | 126 |
| 6.4 The most recent annual financial report .....   | 126 |
| 6.5 The Company's individual financial statements audited and certified by a certified public<br>accountant in the most recent fiscal year.....   | 126 |
| 6.6 If the company or its affiliated enterprises have experienced financial difficulties during the<br>most recent fiscal year or the current fiscal year up to the date of printing of annual report, the<br>annual report shall explain how said difficulties will affect the company's financial status .. | 126 |

|   |     |
|---|-----|
| VII. Review of financial status, business performance, and risk management issues .....   | 127 |
| 7.1 Financial status .....  | 127 |
| 7.2 Financial Performance .....   | 128 |
| 7.3 Cash flow .....   | 129 |
| 7.4 Material capital expenditures in the latest year and impacts on business performance.....   | 129 |
| 7.5 The major causes for profits or losses incurred by investments during the most recent year;<br>rectifications and investment plans for the next year .....  | 130 |
| 7.6 Risk assessment .....   | 131 |
| 7.7 Other important disclosures.....  | 139 |
| VIII. Special remarks.....  | 140 |
| 8.1 Affiliated companies.....   | 140 |
| 8.2 Private placement of securities during the latest year up till the publication date of this<br>annual report.....   | 145 |
| 8.3 Holding or disposal of the company’s shares by its subsidiaries during the latest financial<br>year, up to the publication date of this annual report.....  | 145 |
| 8.4. Other supplementary information.....   | 145 |
| 8.5 Occurrences of events defined under Article 36-3-2 of the Securities and Exchange Act in<br>the latest year up till the publishing date of this annual report that significantly impacted<br>shareholders' equity or security prices..... | 145 |

## I. Report for Shareholders

Ladies and Gentlemen, Dear Shareholders,

In 2020, the pandemic have a major impact on global economic development. To prevent the virus from spreading, countries have closed their cities and the act has severely hit industries like retail and hospitality, hence affected the revenue performance of Flytech.

Under the harsh situation of the epidemic, Flytech sees the crisis as a turning point and takes advantage of the increasing demand for medical solutions. We actively developed new solutions and new products, and successfully secured a respirator Panel PC project. On the one hand, the project paved ways for our future medical solutions. On the other hand, the project helped us adjust our product portfolio and broaden our product lines.

In 2020, Flytech's annual consolidated revenue was NT\$4.43 billion, a decrease of 16.8% from 2019.

In recent years, Flytech has also actively developed our software services. We set up our subsidiary Berry AI which focuses on artificial intelligence and machine learning in 2019, aiming to combine Flytech's existing channels in retail and hospitality to provide smart solutions to our customers. In addition, we also developed a cloud monitoring UEM SaaS service called Inefi to increase the competitiveness of our products by providing software services for monitoring hardware, and to advance toward Flytech's group goal of developing AIoT solutions .

Finally, in the year full of uncertainty, Flytech also released its first ever corporate social responsibility report to share our efforts in education, environment, and industry with society, to communicate with our shareholders, and to build a long term relationship with our shareholders by implementing sustainable relationships with society, environment, and business partners downstream and upstream.

The following reports on financial performance, honors and awards, technology and development, and business environment and prospects:

### **Financial performance**

Flytech's 2020 consolidated annual revenue was NT\$4.43 billion, 16.8% less than 2019. Net profit after tax allocated to the parent company was NT\$590 million, 20% less than 2019. Earnings per share was NT\$4.12.

### **Credentials and awards**

Flytech Technology has won many awards and recognition from all over the world for its outstanding performance. In terms of product design, our touch POS 617 was granted Germany's iF Product Design Award. With respect to corporate governance, Flytech was in the range of top 6%-20% in the "YR 2020 Taiwan Corporate Governance Evaluation Award," maintaining our performance since 2018. Among companies that have a market value between 5B NTD to 10B NTD, Flytech was ranked in top 5% in the "YR 2020 Taiwan Corporate Governance Evaluation Award." Last but not least, Flytech won the 169<sup>th</sup> place of the operating performance of manufacturing industry, 13<sup>th</sup> place of computer peripheral products and equipment and 350<sup>th</sup> place of the comprehensive business operating performance in the "YR2020 Top 5000 Largest Companies in Taiwan" published by China

Credit Information Service Ltd.

### **Technology Development**

Flytech is the industry leader in customized POS design and in manufacturing process, and leads the trend of POS industry hardware specifications. Through continuing sharpen our technics and focus on innovation, we has accumulated 123 intellectual property rights in various countries, ranking highest in the IPC industry in Taiwan.

In response to the market demand, Flytech also launched its hardware monitoring software Inefi in 2020, allowing Flytech's hardware customers to remotely monitor their operating computer and its peripheral. The software is expected to save considerable maintenance costs for Flytech's customers. In the future, Flytech will continue to expand Inefi's functions in response to market demands in order to provide customers with the most complete value-added software services.

### **Operation environment, business operation and development in the future**

Under the influence of the global pandemic, the POS business of Flytech has declined comparing to 2019, but the sales of Panel PC and Mobile POS have shown some growth during the pandemic. On the one hand, it proved the importance of product line diversification, on the other hand, it shows that Flytech's strategy of expanding product lines, moving into different application field, and implementing multiple vertical market entrance have generated its result.

In the future, Mobile POS and KIOSK will be more widely used in response to the development of smart retail, smart hospitality, smart transportation, smart cities, etc., , and Panel PC will also have a strong presence in smart medical, factory automation and other fields. Flytech will seize the trend and continue to develop related products, to invest in related technology, and to cooperate with sales partners from various countries on our sales channel to develop new customers.

Last but not least, Flytech has been actively promoting corporate governance and the implementation of corporate social responsibilities. In the future, we will continue to improve the four major dimensions of corporate governance evaluation: "Maintaining the rights and interests of shareholders and treating shareholders equally", "Strengthening the structure and operation of the board of directors", " "Improve Information Transparency" and "Implement Corporate Social Responsibility" to create higher value for the stakeholders of Flytech

Flytech's competitive advantage "complete products, advanced technology, excellent manufacturing, and strong partner commitment" will continue to lead the company in the future and become the most advanced and innovative service manufacturing company in the industry.

May I wish you all

Have a healthy and prosperous year of 2021

Flytech Technology Co., Ltd.

Lam Tai Seng, Chairman

## II. Company Profile

**2.1 Date of Incorporation:** August 13<sup>th</sup>, 1984

### 2.2 Company History

In the early years, the company designed and sold 8088XT motherboards, I/O interface cards, network interface cards, industrial control cards, and PC peripherals. Currently, the company's main areas of business are industrial computers and peripherals. The company's timeline is as follows:

| Year         | Timeline of Important Events   |
|--------------|--|
| 1984 to 1999 | <ol style="list-style-type: none"> <li>1. The director of the board, Mr. Thomas Lam, established Flytech Technology Co., Ltd on August 13th, 1984, with a starting capital of NT\$1 million. The company develops and produces 8088XT motherboards, I/O interface cards, network interface cards, industrial control cards, etc. At the beginning of the company's operations, because of its R&amp;D and sales capacity, the company performed well and laid a good foundation for its steady growth.</li> <li>2. In 1989, the company developed the world's smallest book-size PC, the 8000 series, which included two personal computers. With them, the company expanded to Europe and North America and received the CEBIT Best Design Award. A German television channel made a special report about the 8000 series, and these computers also received multiple patents domestically and abroad. (Dell has requested authorization for one of the patents).</li> <li>3. In 1990, the company moved to Taipei's Nankang Software Park and successfully developed the 6000 series AT BOOK PC and the 9000 series BOOK desktop PC.</li> <li>4. In 1991, the company successfully developed its 5000 series computer (BOOK PC-2xSlot).</li> <li>5. In 1992, the company received the Best Product Award from the Taiwan External Trade Development Council, and successfully developed the 3000 series 80486 BOOK computers, adding removable disk drive structures for better confidentiality and portable, diversified applications.</li> <li>7. In 1993, the company developed the improved 5000 series, upgrading the BOOK PCs and making them compatible with 80486 processors.</li> <li>8. In 1994, the company successfully developed the 4000 model of the Pentium series, upgrading BOOK PC products' caliber and expanding their applications.</li> <li>9. In 1995, the company's Pentium Book PCs and book-size external multimedia connection series were given two awards, including the Taiwan Excellence Award.</li> <li>10. In 1996, the company successfully developed the 1000 model for the Pentium series and received TUV ISO-9002 certification, as well as the Taiwan Excellence Award for the Pentium multimedia book-size PCs.</li> <li>11. In 1997, the company successfully developed the Pentium BOOK PC and Net PC series. The company also expanded to the realm of industrial computers and developed the 9000 industrial computer series.</li> <li>12. In 1998, the company successfully developed the Pentium-II book-size PCs and industrial computers, IPC-1 (1U), and IPC-2(2U), among others. We received Taiwan Excellence Awards for our Pentium multimedia book-size computers, Pentium II book desktop PC, and net PCs.</li> <li>13. In 1999, we passed the ISO-9001 international quality certification and received Taiwan Excellence Awards for our Socket-370 multifunction net PCs, Cyrix multimedia net PCs, and the world's smallest Socket-370 net PCs. We expanded to core application technology in the computer systems and further developed, produced, and sold 1000- and 4000-model detachable POS systems.</li> </ol> |

|              |   |
|--------------|---|
| 2000 to 2008 | <p>14. In 2000, the company successfully developed the 400-model touch screen POS system and received a National Quality Award in the second year of the award. The factory moved to the Hsi-Chih District to a space of 900 square meters. The company was home to 130 employees, and the capital amount increased to NT\$180,000,000.</p> <p>15. In 2001, passed ISO-14001 certification, the company received the 4th Rising Star Award and successfully developed a new Touch POS series: POS112/500/430. POS 400/500 were awarded the 2001 Taiwan Design Award. In the same year, the company went public and applied for the OTC stock exchange.</p> <p>16. In 2002, passed certification by ISO-9001: 2000, the company set up its Neihu HQ and successfully developed a new POS series, POS 115/435/600/605/505. The POS 500 received the Taiwan Excellence Award from the Ministry of Economic Affairs, as well as the 9th Innovative Research Award, and the 11th National Awards of Outstanding SMEs. In the same year, the company's stocks were listed on the Taiwan OTC Stock Market.</p> <p>17. In 2013, the company successfully developed a new series of POS products: POS 530/630, Mini Web POS 3 series, and OPOS Driver, which is specifically for POS systems. The company actively expanded its business in China; invested in its subsidiary, Flytech (Shanghai) Co., Ltd; and received the 4th Industrial Sustainable Development Excellence Award from the Ministry of Economic Affairs (MOEA).</p> <p>18. In 2004, the company's Neihu HQ was finished, and the company's factories were moved to Wu-Gu Industrial Park, Taipei County. The company's sales team grew and POS, ODM, and KIOSK business offices were established. The company successfully developed its new POS products (POS 430/435 P4) and new kiosk products (K810/K811/K84X). The company received 2nd Taiwan Enterprise Awards - Best Innovative SMB Award, Excellent Innovation and R&amp;D Enterprise, and 2nd Taiwan Golden Root Award, etc. It was ranked as one of the top 500 fastest-growing high-tech companies in the Asia-Pacific region. In the same year, the company was permitted to relist as a high-tech stock.</p> <p>19. In 2005, the company successfully developed POS 460/660 P4, POS122/125, POS104/105/106. The company also developed the new KIOSK series K845/K892 and the Digital Signage K805/807/809. The company was rated as one of the "Top 500 Fast-growing Companies in Electronics and Technology" by China Credit Information Service Ltd, and the POS 460/660/KIOSK 840 products received the Excellently Designed Products Certificate from the Ministry of Economic Affairs.</p> <p>20. In 2006, the company developed new POS products (POS 5000, POS 36X) and new KIOSK products (K72X/79X/K81X/K84X/K895). KIOSK K845A received the 2006 14<sup>th</sup> Industrial Technology Advancement Award from the Industrial Development Bureau, Ministry of Economic Affairs, as well as being one of the 2006 DIMA Photo KIOSK Shoot-Out Winners. The POS 660 series became the 2006 Computex - Best Choice Winner.</p> <p>21. In 2007, the company developed POS 72X/79X and new KIOSK products (K847/893, K207, KPC5) and Panel PCs (K830/K877). The K870 Series became the 2007 Computex Best Choice Winner, and the company was nominated as one of the "Top 500 Fast-growing Companies in Electronics and Technology." It was rated by CW magazine as one of the "Top 100 Highest-Performing Companies in 2006" and one of Asia's 200 Best Under A Billion by Forbes magazine. The company was also rated as one of Taiwan's "Best Potential 99" manufacturers by ET today.</p> |
|--------------|---|



|              |   |
|--------------|---|
| 2000 to 2008 | <p>22. In 2008, the company successfully developed a new POS series and peripherals (POS 370/475/355), a new KIOSK series (K897/795/795T/832.835), and Panel PCs (PA23/24, Bedside Terminal TC200). Multiple series of the company's products were selected by Computex Taipei to be used at the conference and as computers for application displays in 2008. The company was rated by Forbes Asia as one of "Asia's 200 Best Under a Billion," one of the "Top 500 Fast-growing Companies in Electronics and Technology in 2008" by China Credit Information Service, and one of the "Top 100 Taiwan Tech Companies in 2008."</p>   |
| 2009 to 2015 | <p>23. In 2009, the company successfully developed industrial computers and peripherals: P335/345/357/88X/234, KPC1/6, K78X, Bedside Terminal PA38. Passed ISO-9001:2008 and ISO-13485 certification. Again multiple series of the company's products were selected to be used at the 2009 Computex conference and as computers for application display. The KIOSK series were used as guidance computers by the 2009 World Games. The company was rated by Global View Monthly as part of the "A+ Club," the top 69 Taiwan companies that are the best money makers for shareholders. Business Next rated the company as one of the Top 100 Tech Companies – Overall Taiwan/China/World Ranking. China Credit Information Service rated it as one of the "Top 500 Fast-Growing Companies in Electronics and Technology in 2009," and one of the "Top 100 Taiwan Tech Companies in 2009."</p> <p>24. In 2010, the company developed its industrial computer series and peripherals: P385/78X/137, P223/235, K773/88X, KPC7, and Bedside Terminal K938. The company was again named by Global View Monthly as part of the "A+ Club," the 69 Taiwan companies that are the best money makers for shareholders. Its POS P235 received the 2010 Reddot Design Award and the 2010 iF Best Product Design Award. For the third year in a row, multiple series of the company's products were selected by Computex Taipei to be used at the conference and as computers for application display. The company was invited to exhibit at the 2010 Taiwan Design Expo. Our products were also used for ticket sales, checkouts, and guidance systems at the 2010 Taipei International Flora Exposition.</p> <p>25. In 2011, the manufacturing center at Hwa Ya Technology Park, Linkou was finished, giving the company three times as much production capacity as before. We successfully developed a new series of industrial computers and peripherals: P355H/554/485/495, POS8000, P14X/185/195, K75X/787, Bedside Terminal K936. POS562 was awarded Germany's iF Best Product Design Award. Multiple series of the company's products were selected by Computex to be used at the conference and as computers for application display. Development Plan for Flytech's Service-oriented Manufacturing Value Chain System approved by the Industrial Development Bureau of the Ministry of Economic Affairs' Special Tech Endorsement Project.</p> <p>26. In 2012, the Manufacturing Center officially moved to Linkou's Hwa Ya Technology Park, and its production capacity was in full power. It successfully developed a new series of industrial computers and peripherals: P345N/385N, PA72/93, K755/759, P145/149, Bedside Terminal PA79. Multiple series of the company's products were selected by Computex to be used at the conference and as computers for application display, and its POS products received Germany's iF Best Product Design Award. Again, the company was chosen by China Credit Information Service as one of the "Top 500 Fast-growing Companies in Electronics and Technology."</p> |

|              |  |
|--------------|--|
| 2009 to 2015 | <p>27. In 2013, we successfully developed a new industrial computer series and peripherals: P375N/391/395/425, PA35/97/98, Bedside Terminal K948. Multiple series of the company's products were selected by Computex Taipei to be used at the conference and as computers for application display, and our PA Series POS received the iF Best Product Design Award and passed ISO-27001 Information Security Certification.</p> <p>28. IN 2014, the company celebrated its 30<sup>th</sup> anniversary and developed a new industrial computer series and peripherals: P314/325/355N/375/485/P495, KPC8, K77X/78X/73X/74X, and Mobile POS series P263/265. Again, the company was named one of the Top 5000 Large Companies in Taiwan, 2014. The company was also ranked 17<sup>th</sup> in the computer accessory industry, 40<sup>th</sup> in terms of performance in the manufacturing sector, and 95<sup>th</sup> in combined ranking for company performance by China Credit Information Service. Multiple series of the company's products were selected by Computex Taipei to be used at the conference and as computers for application display.</p> <p>29. In 2015, the company successfully developed its new industrial computer series and peripherals: J640/690/690L/240, new MB compatible with Panel PC series, K74X/75A/76X/778, Payment Terminal T635/635M/636/645/646. Awarded at the 3<sup>rd</sup> Potential Taiwan Mittelstand Awards by the Ministry of Economic Affairs. Received the Intel 2015 Outstanding Business Achievement Award. Multiple series of the company's products were selected by Computex Taipei to be used at the conference and as computers for application display. Flytech ranked among the top one-third in the Second Corporate Governance Evaluation (In the year 2015 as promulgated in April 2016)</p>  |
| 2016 to 2019 | <p>30. In 2016, the company successfully developed industrial computers and peripherals: P395/531/P534/255, K735/75C/767, new MB compatible with POS and Panel PC series P325/357/795/K75X, Payment Terminal T635M/602/603, and T605, T606 A/B/C series. We purchased renowned U.K. retail technology provider Box Technologies (Holdings), and we acquired 100% of this subsidiary's shares. Our Panel PC 18.5 achieved the IP67-level waterproof grade. We adopted 304 food-grade and medical-grade stainless steel material for sweat and stain proofing. For this we received the iF 2016, Computex d&amp;I awards, and many other honors. We were recognized by the Ministry of Economic Affairs' Bureau of Foreign Trade as one of the top 500 manufacturers in imports/exports. Multiple series of the company's products were selected by Computex Taipei to be used at the conference and as computers for application display. Passed certificate renewal review ISO14001: 2015 version certification (validity period from September 22, 2016 through September 21, 2019). Flytech ranked among the top one-third in the Third Corporate Governance Evaluation (In the year 2016 as promulgated in April 2017)</p> <p>31. In 2017, the company successfully developed the industrial computer series and new peripheral products: P335N2/P455/ P544, B41/PB53/PB55/PB57/PB61/PB62/PB63/PB65/PB66/PB77, P274. It likewise successfully developed a monitoring system that users can operate from a mobile phone APP, the patented System Diagnostic Recorder (SDR) device for critical part scenarios and the corresponding mobile phone APP. We were recognized by Ministry of Economic Affairs' Bureau of Foreign Trade as one of the top 500 manufacturers in imports/exports. Touch POS P655 was awarded the Grand Award for Best Design in the 2017 German iF Design Award, with a continual win in the Computex Taipei Computer Show, using multiple series of models as venues and application display machines; Ranked among the Top One-Third Plus in the 4th Corporate Governance Appraisal Competition (The honors of Year 2017 as announcement in April 2018).</p> |

|              |   |
|--------------|---|
| 2016 to 2019 | <p>32. In 2018, the company successfully developed industrial computer series and new peripheral products: P337N2/P655/ T605A+/K75D/PB81/PB85/PB88/K85B. New-generation P274 continues to lead the industry in the field of Mobile POS. Through the synergistic effect of the integrated channel supply chain of the British subsidiary Box Technologies (Holdings), the British domain was successfully expanded, injecting Flytech Technology Co., Ltd. Group's revenues. Awarded the 12th place in the Computer Peripheral Equipment Industry of the China Credit Information Service in the "Top 5000 Large Enterprises in Taiwan in 2018" Competitions. Multiple series of the company's products were selected by Computex Taipei to be used at the conference and as computers for application display for 10 consecutive years. The certificate renewal passed Taiwan Intellectual Property Management System (TIPS) (Level A 2016 Version) certification of the Ministry of Economic Affairs. Awarded among the top 20% best good results in the Fifth Corporate Governance Evaluation (the honors of 2018 announced in April 2019).</p> <p>33. During 2019, Flytech successfully completed research &amp; development for such computer and peripheral products including notably: P337/P458/P617/P667/P274/K757V/K865/K86B/K959/PB82/PB88/PB96/PC12/P155N with successful pass of the strict review process for replacement of certificates of honors: ISO9001: 2015 Version (valid starting from August 13, 2019 until August 21, 2020); ISO13485: 2016 Version (valid starting from January 28, 2019 until January 27, 2022), ISO14001: 2015 Version (valid starting from September 22, 2019 until September 21, 2022), ISO27001: 2013 Version (valid starting from July 31, 2019 until June 25, 2022). Honorably awarded the 12th place in the Computer Peripheral Equipment Industry of the China Credit Information Service in the "Top 5000 Large Enterprises in Taiwan in 2019" Competitions. KIOSK K86B was honorably the Best European Design Award 2019. Awarded every year in eleven years in a row in the Computex Taipei Computer Show, adopting multiple series of models as venues and application display machines; honorably rated among the top 20% in the 6th Corporate Governance Evaluation (honors of Year 2019 announced in April 2020)</p> |
| 2020         | <ol style="list-style-type: none"> <li>1. Flytech announced its successful research &amp; development of new computer series and peripherals, including notably New All-in-one POS Series, New Mobile POS Series; New Panel PC Series, New KIOSK Series; New PC POS Series, Non-PC and New MB Matching Host Series: P615, P665, P617N, P667N, PB96, M276, M278, K736, K737, K738, K739, K889, PC17, PC18, PC26</li> <li>2. Touch POS P617 was honorably awarded the【Grand Award for Best 2020 iF Design】in Germany.</li> <li>3. Flytech successfully launched Hardware Monitoring Service Software known as Inefi, enabling Flytech customers to remote-control the operations of their machines and peripherals, enabling them to control at a distance, remarkably helping Flytech customers conserve significant costs required for maintenance &amp; upkeep service.</li> <li>4. Flytech successfully passed the strict review for license renewal: ISO9001: 2015 Version (valid starting from December 3, 2020 until August 31, 2023), ISO14001: 2015 Version (valid starting from December 3, 2020 until September 21, 2022).</li> <li>5. Flytech successfully passed ISO45001 Certification for Occupational Safety &amp; Health Manager System 2018 Version (valid starting from December 1, 2020 until November 30, 2023).</li> <li>6. Awarded the 13th place in the Computer Peripheral Equipment Industry of the China Credit Information Service in the "Top 5000 Large Enterprises in Taiwan in 2020" Competitions.</li> </ol>   |

|      |  |
|------|--|
| 2020 | <ol style="list-style-type: none"><li data-bbox="336 226 1417 465">7. Continually in coordination with “Flytech Foundation” in sponsoring a variety of social public welfare programs along with the promotion into science &amp; technology innovation programs, e.g. Design For Taiwan focusing on one-year seminar and workshop toward the university/college students where we invited well-known experts both in Taiwan and throughout the world to render instructions in the seminars, focusing on Taiwan-based innovation culture where Flytech fulfilled its corporate social responsibility (CSR).</li><li data-bbox="336 479 1417 808">8. Here at the Company, we started compiling the first “Corporate Social Responsibility (CSR) Report which was officially issued to public in February 2021, concretely revealing Flytech’s incessant endeavors and performance toward corporate social responsibility (CSR) with feedback in real time to the stakeholders on their requirements and expectations. It is our earnest hope that through such warm mutual understanding amidst close two-way communications, we at Flytech would set up close ties with our valued customers and entire society into sustainable co-fusion partnership toward our brilliant future.</li><li data-bbox="336 822 1417 927">9. Ranked top 20 in the listed company group of the Corporate Governance Evaluation for three years in a row, and the good performance of top 5% in the listed company group with a market value between US\$5 and US\$10 billion.</li></ol> |
|------|--|

### III、Corporate Governance Report

#### 3.1 Organization

##### 3.1.1 Organizational Chart (Date : April 30, 2021)

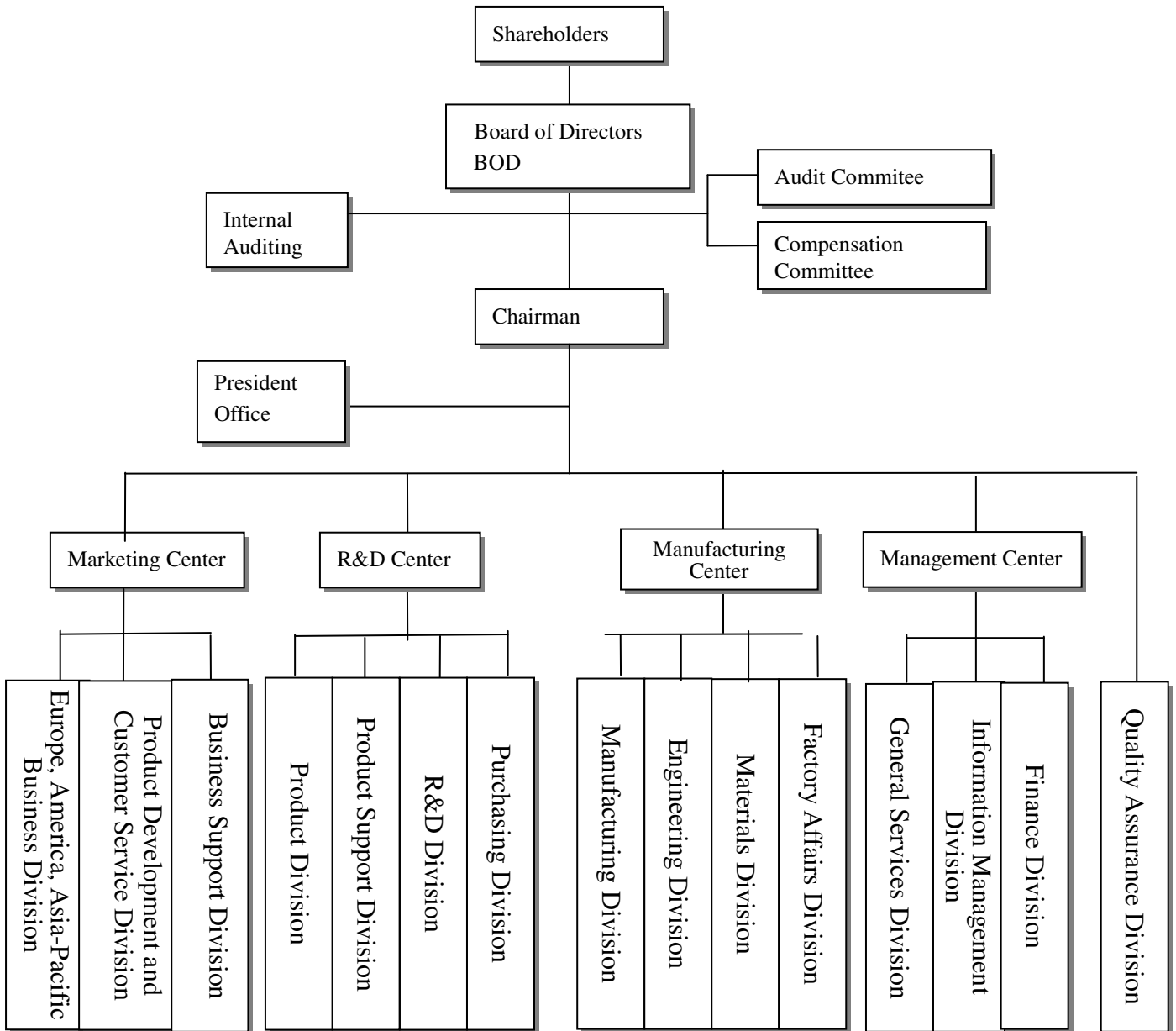

## 3.1.2 Major Corporate Functions

| Department                 | Main Responsibilities  |
|----------------------------|--|
| President Office           | Establish corporate culture, promote corporate governance, set growth visions and operational goals, lead the four centers towards the goals, promote and supervise corporate social responsibility implementation and integrity operations, review and revise various management systems, plan and implement human resources policies, recruit talents, conduct training programs and performance assessments, manage group subsidiary systems and business performance. Investment strategy formulation and management, external information release, media corporate contact, contract and legal affair review, intellectual property management. |
| Internal Auditing          | Evaluate the operational risk of all operational units and validity of internal control systems, set annual audit plans, and implement and propose improvement recommendations according to the plan.  |
| Marketing Center           | Set product positioning and deploy global marketing strategies, engage in Touch POS, Panel PC, Mobile POS, KIOSK, PC POS, and other IPC products related market development, business orders, and customer services, differential analysis and management improvement.   |
| R&D Center                 | New product system, MB, and related peripheral product development, design, trial production, trail planning operations, and new technology R&D. Raw material production equipment supplier development, inquiry and price negotiation, purchase plans, purchase operations, and management, differential analysis and management improvement.   |
| Manufacturing Center       | Material management for various products, production capacity plans, schedule management, product manufacture, site management, engineering management, equipment management, and inventory management, differential analysis and management improvement. .  |
| Management Center          | Various property equipment management, general affairs management, workplace labor safety and hygiene management, and information security policy formulation and management. Plan and implant accounting, cost, finance, budget, taxation, capital, and other operations; prepare financial statements and differential analysis, supervise group subsidiary financial operations, prepare consolidated financial statements and differential analysis, assist the General Manager's Office in promoting corporate governance, corporate social responsibility, and integrity operations.   |
| Quality Assurance Division | Set up quality policies, establish and maintain quality management systems, incoming materials/manufacturing process/finished products quality inspection, correction prevention & abnormal measures, instrument calibration, after-sales maintenance services, assisting in procurement and implementation of supplier qualification and evaluation, differential analysis and management improvement.  |

### 3.2 Directors and Management Team

#### 3.2.1 Directors

April 30, 2021

| Title                | Nationality / Country of Origin | Name                           | Gender | Date Elected | Term (Years) | Date First Elected | Shareholding when Elected |        | Current Shareholding |        | Spouse & Minor Shareholding |        | Shareholding by Nominee Arrangement |   | Experience ( Education )  | Other Position | Executives or Directors who are spouses or within two degrees of kinship |              |          | Note |
|----------------------|---------------------------------|--------------------------------|--------|--------------|--------------|--------------------|---------------------------|--------|----------------------|--------|-----------------------------|--------|-------------------------------------|---|---|----------------|--|--------------|----------|------|
|                      |                                 |                                |        |              |              |                    | Shares                    | %      | Shares               | %      | Shares                      | %      | Shares                              | % |   |                | Title  | Name         | Relation |      |
| Chairman             | R.O.C.                          | Lam Tai Seng                   | Male   | 2018.06.08   | 3 years      | 1984.08.13         | 16,217,505                | 11.34% | 16,423,263           | 11.48% | 11,040,443                  | 7.72%  | —                                   | — | EMBA Guanghai School of Management, Peking University<br>EMBA of National Chengchi University<br>Department of electronic engineering, National Taiwan University<br>President of Flytech Technology                  | Note 1         | Director   | Wang Wei Wei | Spouse   |      |
| Vice Chairman        | R.O.C.                          | Liu Chiu Tsao                  | Male   | 2018.06.08   | 3 years      | 2006.06.14         | 200,588                   | 0.14%  | 107,637              | 0.08%  | —                           | —      | —                                   | — | MBA University of Oklahoma, USA<br>President of Flytech Technology<br>Vice President of Lite-on Technology Corp.<br>VP of Liteon Technology Corporation<br>President of Flytech Technology                            | Note 2         |  |              |          |      |
| Director             | R.O.C.                          | Wang Wei Wei                   | Female | 2018.06.08   | 3 years      | 1984.08.13         | 11,040,443                | 7.72%  | 11,040,443           | 7.72%  | 16,423,263                  | 11.48% | —                                   | — | MBA University of Tennessee, USA<br>SVP of Flytech Technology   | Note 3         | Chairman   | Lam Tai Seng | Spouse   |      |
| Director             | R.O.C.                          | Yi Hua Investment              | Male   | 2018.06.08   | 3 years      | 2018.06.08         | 78,022                    | 0.05%  | 78,022               | 0.05%  | —                           | —      | —                                   | — | Doctor of Management Central South University, China<br>MBA, Business Administration, Lake Superior State University, U.S.A.<br>VP of RD and Manufacturing Department, KYE Systems Corp.<br>EVP of Flytech Technology | None           |  |              |          |      |
|                      |                                 | Representative: Liaw Jui Tsung |        |              |              |                    | —                         | —      | 1,644,869            | 1.15%  | —                           | —      | —                                   | — |   |                |  |              |          |      |
| Independent director | R.O.C.                          | Chen Kuo Hong                  | Male   | 2018.06.08   | 3 years      | 2001.04.10         | 130,000                   | 0.09%  | 130,000              | 0.09%  | —                           | —      | —                                   | — | Department of electronic engineering, National Taiwan University<br>Chairman of Howtech Technology Co., Ltd<br>President of Tailyn technologies, inc.   | Note 4         |  |              |          |      |
| Independent director | R.O.C.                          | Hsieh Han Chang                | Male   | 2018.06.08   | 3 years      | 2012.6.15          | —                         | —      | —                    | —      | —                           | —      | —                                   | — | EMBA of National Chengchi University<br>VCEO of Yeangder Group<br>President of Shihlin Electric and Engineering Corp<br>President of the Ambassador Hotel Led   | Note 5         |  |              |          |      |
| Independent director | R.O.C.                          | Liang Wei Ming                 | Male   | 2019.06.12   | 2 years      | 2019.06.12         | —                         | —      | —                    | —      | —                           | —      | —                                   | — | University of Iowa IE & MBA<br>Department of Industrial Engineering, Tunghai University<br>VP of Chief Land Electronic Co., Ltd.<br>President and Director of Sinbon Electronics Company Ltd.                         | Note 6         |  |              |          |      |

Note 1: Flytech Technology USA INC., Chairman of the Board, Flytech Technology Hong Kong Ltd., Chairman of the Board, Flytech Technology (Shanghai) Co.,Ltd.,Chairman of the Board, Yeedex Electronic Corporation, Chairman of the Board, Yi Hua Investment Co., Ltd., Chairman of the Board

Note 2: Flytech Co., Ltd., Vice Chairman; Fei Mao Electronic (Shanghai) Co., Ltd. Director

Note 3: Chairman of Flytech Technology Hong Kong Ltd., Chairman of Flytech USA International Co., Ltd., Chairman of Flytech HK International Co., Ltd., Chairman of Flytech CN International Co., Ltd., Chairman of Flytech Technology (Shanghai) Co.,Ltd., CEO of Bluerider ART

Note 4: Chairman of Howteh Technology Co., Ltd., Board Director of Thilyn Technologies, Inc., Board Director of Stark technology inc., Chairman of Chaintel Technology Co., Ltd., Independent director of Ability Enterprise Co., Ltd.

Note 5: VCEO of Yeangder Group, MD & COO of Shihlin Electric and Engineering Corp, Director and COO of the Ambassador Hotel Led, Director of HCT LOGISTICS CO., LTD., Supervisor of Yeangder Invested Company, Chairman of Hsin Ling Electric and Engineering Corp, Director of Chuan Lin Scien-Technical Corp., Director of Ruei Lin Electric & Engineering Corp. , Director of Xiamen Shihlin Electric and Engineering Co., Ltd, Director and President of Yeangder Entertainment Co.Ltd, Director of Yeang-der Senior High School, Director of SEEC International Trading Ltd., Director of SEEC International Holdings Ltd., Director of Kingdon Trading Shanghai Co., Ltd, Director of Shihlin Electric (Suzhou) Power Equipment Co., Ltd., Director of Yeangder Culture and Education Foundation, Vice CEO of memorial Foundation of Mr.Ching Teh Hsu, Supervisor of Yeangder safety consultant Corp., Director of Sankyo Company Ltd., Director of Aces Electronics Co., Ltd., Director of Mec Imex Inc. (Corporate representative)

Note 6: Worldwide Wire Harnesses Ltd. director (corporate representative), SINBON Electronics general manager and director, Starconn Electronics Vice President, Tungcheng SINBON Electronics chairman (corporate representative), Jiangyin SINBON Electronics director (corporate representative), Hong Kong SINBON Electronics director (corporate representative), Beijing SINBON Electronics director (corporate representative), Beijing Tungan SINBON Electronics director (corporate representative), Shenzhen SINBON Electronics director (corporate representative), Shanghai SINBON Electronics director (corporate representative), Jiangsu EMS5 Technology Inc. chairman (corporate representative), Kunshan EMS5 Technology Inc. chairman (corporate representative), EMS5 Technology Inc. director (corporate representative).

**Major shareholders of the institutional shareholders**

April 30, 2021

| Name of Institutional Shareholders | Major Shareholders |
|------------------------------------|--------------------|
| Yi Hua Investment                  | Lam Tai Seng       |



**Professional qualifications and independence analysis of directors**

| Name   | Condition  |   |  | Independence Criteria |   |   |   |   |   |   |   |   |    |    |    | Number of Other Public Companies in Which the Individual is Concurrently Serving as an Independent Director |
|--|--|---|--|-----------------------|---|---|---|---|---|---|---|---|----|----|----|---|
|  | Meet One of the Following Professional Qualification Requirements, Together with at Least Five Years Work Experience   |   |  | 1                     | 2 | 3 | 4 | 5 | 6 | 7 | 8 | 9 | 10 | 11 | 12 |   |
|  | An Instructor or Higher Position in a Department of Commerce, Law, Finance, Accounting, or Other Academic Department Related to the Business Needs of the Company in a Public or Private Junior College, College or University | A Judge, Public Prosecutor, Attorney, Certified Public Accountant, or Other Professional or Technical Specialist Who has Passed a National Examination and been Awarded a Certificate in a Profession Necessary for the Business of the Company | Have Work Experience in the Areas of Commerce, Law, Finance, or Accounting, or Otherwise Necessary for the Business of the Company |                       |   |   |   |   |   |   |   |   |    |    |    |   |
| Chairman- Lam Tai Seng                               |  |   | V  |                       |   |   |   | V | V | V |   | V |    | V  | V  | Not holding a concurrent position.  |
| Vice Chairman- Liu Chiu Tsao                         |  |   | V  | V                     | V | V | V | V | V | V | V | V | V  | V  | V  | Not holding a concurrent position.  |
| Director- Wang Wei Wei                               |  |   | V  |                       |   |   |   | V | V |   |   | V |    | V  | V  | Not holding a concurrent position.  |
| Representative of Yi Hua Investment : Liaw Jui Tsung |  |   | V  | V                     | V | V | V | V | V | V | V | V | V  | V  | V  | Not holding a concurrent position.  |
| Chen Kuo Hong  |  |   | V  | V                     | V | V | V | V | V | V | V | V | V  | V  | V  | Independent Director of Ability Enterprise Co., Ltd   |
| Hsieh Han Chang                                      |  |   | V  | V                     | V | V | V | V | V | V | V | V | V  | V  | V  | Not holding a concurrent position.  |
| Liang Wei Ming                                       |  |   | V  | V                     | V | V | V | V | V | V | V | V | V  | V  | V  | Not holding a concurrent position.  |

1. Not an employee of the Company or any of its affiliates.
2. Directors and supervisors not affiliated with the company or is conglomerates (not limited to concurrent independent directors designated by the company, parent company, subsidiary, or subsidiary under the same parent company by the local regulations).
3. Not a natural-person shareholder who holds shares, together with those held by the person's spouse, minor children, or held by the person under others' names, in an aggregate amount of 1% or more of the total number of outstanding shares of the Company or ranking in the top 10 in holdings.
4. Not managers listed in (1) or spouses, within second-degree relatives or within third-degree immediate relatives.
5. No direct holding of more than 5% of shares issued by the company, not ranking top five in shareholding, and not representatives appointed in Subparagraph 1 and 2 of Article 27 of the Company Act serving as corporate shareholder directors, supervisors, or employed persons, (not limited to concurrent independent directors designated by the company, parent company, subsidiary, or subsidiary under the same parent company by the local regulations).
6. Directors, supervisors, or employed persons of other companies not exceeding half of the company's director seats or shares with voting rights controlled by the same person (not limited to

concurrent independent directors designated by the company, parent company, subsidiary, or subsidiary under the same parent company by the local regulations).

7. Not the same person as the company's chairman, general manager (or equivalent position); not the spouse's company or institution board of directors (directors), supervisors (members of the board of supervisors), or employed persons (not limited to concurrent independent directors designed by the company, parent company, subsidiary, or subsidiary under the same parent company by the local regulations).
8. Board of directors (directors), supervisors (members of the board of supervisors), managers, or shareholders with more than 5% shareholding of specific companies or institutions without financial or business dealings with the company (not limited to specific companies or institutions with more than 20% but not exceeding 50% of shares issued by the company and concurrent independent directors designated by local regulations of the company and its parent company and subsidiary company or subsidiaries under the same parent company).
9. Professionals engaged in commercial, legal, financial, accounting, and other related services whose audits are not provided by the company or its conglomerates or whose cumulative rewards in the recent two years have not exceeded NT\$500,000, sole proprietors, company or institution owners, partners, directors (board of directors (directors), supervisors (members of the board of supervisors), managers, and their spouses. (not limited to the members of the Remuneration Committee, Public Takeover Review Committee, or Mergers and Acquisition Special Committee performing their duties in accordance with the Securities Exchanges Act or the Business Mergers And Acquisitions Act)
10. Not having a marital relationship, or a relative within the second degree of kinship to any other director of the Company.
11. Not been a person of any conditions defined in Article 30 of the Company Law.
12. Not a governmental, juridical person or its representative as defined in Article 27 of the Company Law

### 3.2.2 Management Team

Apr 30, 2021

| Title  | Nationality/<br>Country of<br>Origin | Name             | Gender | Date<br>Effective | Shareholding |       | Spouse & Minor<br>Shareholding |       | Shareholding<br>by Nominee<br>Arrangement |   | Experience ( Education )   | Other Position   | Managers who are Spouses or<br>Within Two Degrees of Kinship |      |          | Note |
|--|--------------------------------------|------------------|--------|-------------------|--------------|-------|--------------------------------|-------|---|---|--|--|--|------|----------|------|
|  |                                      |                  |        |                   | Shares       | %     | Shares                         | %     | Shares                                    | % |  |  | Title  | Name | Relation |      |
| President  | R.O.C.                               | Chuo Chun Hung   | Male   | 2020.01           | 20,600       | 0.01% | 1,153                          | 0.00% | —   | — | Engineering Science, National Cheng Kung University<br>AVP, Uniwill Computer<br>AVP, JPC Company<br>VP, SZBroad Tech.  | 1. Box Technologies Limited,<br>Director<br>2. Lo Chieh System Co., Ltd.,<br>Chairman (corporate<br>representative)<br>3. Hua Chieh Intellectual Co.,<br>Ltd., Director (corporate<br>representative)<br>4. Pu Ta System Co., Ltd.,<br>Director (corporate<br>representative)  |  |      |          |      |
| President concurrently<br>serving as the Marketing<br>Center Supervisor                        | R.O.C.                               | Shyu Jia Horng   | Male   | 2020.01           | 24,118       | 0.02% | —                              | —     | —   | — | MS, NYU Electrical Engineering<br>Sales Div. Director Supply Chain<br>Management Div. Director of<br>Mediatek Inc  | 1. Hua Chieh Intellectual Co.,<br>Ltd., Chairman (corporate<br>representative)<br>2. box Technologies (Holdings)<br>Limited, Director<br>3. box Technologies Limited,<br>Director<br>3. Flytech USA International Co.,<br>Ltd, Chairman<br>4. Flytech HK International Co.,<br>Ltd, Chairman<br>5. Flytech CN International Co.,<br>Ltd, Chairman<br>6. Fei Hsun Investment Co., Ltd.,<br>Chairman |  |      |          |      |
| Assistant Vice President<br>of Marketing Center  | R.O.C.                               | Hung Dong Chang  | Male   | 2013.09           | 88,246       | 0.06% | 28,054                         | 0.02% | —   | — | EMBA , Soochow University<br>Manager, Evertop Wire Cable<br>Corporation  | .box Technologies Limited ,<br>Director  |  |      |          |      |
| Vice President of R&D<br>Center  | R.O.C.                               | Liu Yun Ping     | Male   | 2011.10           | 30,362       | 0.02% | —                              | —     | —   | — | Executive program, National<br>Cheng-Chi University<br>EMBA of National Chengchi<br>University<br>SAVP, Elitegroup Computer<br>Systems   | None   |  |      |          |      |
| Assistant Vice President<br>of Manufacturing Center  | R.O.C.                               | Chen Chun Hsiung | Male   | 2014.02           | —            | —     | —                              | —     | —   | — | Electronic Engineering, Hwa Hsia<br>University of Technology<br>Manager of Material Management<br>Center, Top Vision Electronics<br>Procurement Manager, Lite-On<br>Technology Corp.<br>Director, Division of Logistics,<br>Flytech Technology Co., Ltd. | None   |  |      |          |      |
| Vice President of<br>Management Center<br>concurrently serving as<br>the Chief Finance Officer | R.O.C.                               | Lee Mei Huei     | Female | 2006.01           | 99,986       | 0.07% | —                              | —     | —   | — | EMBA of National Chengchi<br>University<br>EMBA, Department of Business<br>Administration, National Taipei<br>University<br>Assistant Manager, Division of<br>Finance, Flytech Technology Co.,<br>Ltd.   | 1. Hua Chieh Intellectual Co.,<br>Ltd., Supervisor<br>2. Fei Mao Electronic (Shanghai)<br>Co., Ltd., Director  |  |      |          |      |

### 3.2.3 Remuneration of Directors, Supervisors, President, and Vice President

#### 1. Remunerations for General Directors and Independent Directors

As of 2020/12/31 Unit: NT\$ thousands; shares

| Title                | Name   | Remuneration of Directors      |   |                   |   |                                 |   |                         |   | Ratio of Total Remuneration (A+B+C+D) to Net Income (%) (Note 7) |   | Relevant Remuneration Received by Directors Who are Also Employees |   |   |       |   |       | Ratio of Total Compensation (A+B+C+D+E+F+G) to Net Income (%) (Note 7) |  | Compensation Paid to Directors from an Invested Company Other than the Company's Subsidiary |       |      |
|----------------------|--|--------------------------------|---|-------------------|---|---------------------------------|---|-------------------------|---|--|---|--|---|---|-------|---|-------|--|--|---|-------|------|
|                      |  | Base Compensation (A) (Note 1) |   | Severance Pay (B) |   | Bonus to Directors (C) (Note 2) |   | Allowances (D) (Note 3) |   | Salary, Bonuses, and Allowances (E) (Note 4)                     |   | Severance Pay (F) (Note 6)   |   | Profit Sharing- Employee Bonus (G) (Note 5) |       |   |       |  |  |   |       |      |
|                      |  | The Company                    | Companies in the consolidated financial statements (Note 6) | The Company       | Companies in the consolidated financial statements (Note 6) | The Company                     | Companies in the consolidated financial statements (Note 6) | The Company             | Companies in the consolidated financial statements (Note 6) | The Company  | Companies in the consolidated financial statements (Note 6) | The Company  | Companies in the consolidated financial statements (Note 6) | The Company                                 |       | Companies in the consolidated financial statements (note 6) |       | The Company  | Companies in the consolidated financial statement (Note 6) |   |       |      |
|                      |  |                                |   |                   |   |                                 |   |                         |   |  |   |  |   | Cash  | Stock | Cash  | Stock |  |  |   |       |      |
| Chairman             | Lam Tai Seng   |                                |   |                   |   |                                 |   |                         |   |  |   |  |   |   |       |   |       |  |  |   |       |      |
| Director             | Wang Wei Wei   |                                |   |                   |   |                                 |   |                         |   |  |   |  |   |   |       |   |       |  |  |   |       |      |
| Director             | Liu Chiu Tsao  |                                |   |                   |   |                                 |   |                         |   |  |   |  |   |   |       |   |       |  |  |   |       |      |
| Director             | Yi Hua Investment Limited Company Representative: Liaw Jui Tsung | 0                              | 0   | 0                 | 0   | 3,500                           | 3,500   | 980                     | 980   | 0.76%  | 0.76%   | 7,122  | 7,122   | 108   | 108   | 3,020   | 0     | 3,020  | 0  | 2.50%   | 2.50% | None |
| Independent director | Chen Kuo Hong  |                                |   |                   |   |                                 |   |                         |   |  |   |  |   |   |       |   |       |  |  |   |       |      |
| Independent director | Hsieh Han Chang  |                                |   |                   |   |                                 |   |                         |   |  |   |  |   |   |       |   |       |  |  |   |       |      |
| Independent director | Liang Wei Ming   |                                |   |                   |   |                                 |   |                         |   |  |   |  |   |   |       |   |       |  |  |   |       |      |

1. State the relevance of the independent director remuneration payment policy, system, standard, and structure and remuneration amount based on duties, risks, input time, and other factors:  
The company's policy of remuneration payments to all the directors (including independent directors) in reference to the following terms has been drafted into a payment plan submitted to the Remunerations Committee and Board of Directors for review and approval.

- Based on the directors' degree of involvement and the value of contribution in the board of directors for the current year (number of meetings attended, number of motions, risk of motions, majority of motions, review time) and other operations (interviews and discussions with CPAs/internal auditors/management level).
- Standards of the same trade at home and abroad.
- Annual performance results of individual directors and the board of directors.
- The company's overall operational performance.
- Provisions of the Company Charter: If the company has incurred profits for the year, 3%~15% shall be allocated as remunerations for employees and no higher than 3% shall be allocated as remunerations for directors.

The total amount of remunerations for the company directors paid by company and all the companies in the consolidated statement in 2020 accounts for 2.50% of after-tax net profit.

2. Remunerations claimed by the directors for providing services to all the companies in the financial statement in the most recent year (such as serving as non-staff consultants) other than the disclosure in the table above: None.

Note 1: It refers to the remuneration toward directors for 2020 (including directors' salary, job allowance, severance payment, various bonuses, incentives, etc.)

Note 2: It refers to the amount of remuneration to directors to be allocated in 2020 as duly resolved in the board of directors meeting.

Note 3: It refers to the traffic allowances payable to directors in 2020.

Note 4: It refers to the salary, job allowances, severance pay, various bonuses, incentives, traffic allowances, special expenditures, various allowances, dormitory fares, provision of vehicles and such objects in kind received by directors and concurrent employees (including the concurrent general manager, deputy general manager(s), other managers and employees) in 2020. Besides, such "shares-based payments" under IFRS 2, including acquired employee stock option certificates, new shares with restricted employee interests, and participation in subscription to new shares through capital increase through cash injection should be counted into the remuneration.

Note 5: Remuneration to employees (including stocks and cash) obtained by directors and concurrent employees (including the concurrent general manager, deputy general managers, other managers, and employees) of the proposed distribution for 2020 based on the actual distribution ratio in 2019.

Note 6: It refers to the total amount of the remuneration paid by all companies (including the Company itself) in the consolidated financial statements to the directors of the Company.

Note 7: It refers to the net profit after tax amidst the individual financial statements of 2020.

## 2. Remuneration of the President and Vice President

As of 2020/12/31 Unit: NT\$ thousands; shares

| Title          | Name                  | Salary (A)<br>(Note 1) |   | Severance Pay (B) |   | Bonuses and Allowances (C)<br>(Note 2) |   | Profit Sharing- Employee Bonus (D) (Note 3) |       |   |       | Ratio of total compensation<br>(A+B+C+D) to net income (%) (Note 5) |   | Compensation Paid to Directors from an Invested Company Other than the Company's Subsidiary |
|----------------|-----------------------|------------------------|---|-------------------|---|--|---|---|-------|---|-------|---|---|---|
|                |                       | The Company            | Companies in the consolidated financial statements (Note 4) | The Company       | Companies in the consolidated financial statements (Note 4) | The Company                            | Companies in the consolidated financial statements (Note 4) | The Company                                 |       | Companies in the consolidated financial statements (Note 4) |       | The Company   | Companies in the consolidated financial statements (Note 4) |   |
|                |                       |                        |   |                   |   |  |   | Cash  | Stock | Cash  | Stock |   |   |   |
| President      | Chuo Chun Hung        | 10,551                 | 10,551  | 351               | 351   | 1,940                                  | 1,940   | 11,000                                      | 0     | 11,000  | 0     | 4.04%   | 4.04%   | None  |
| President      | Shyu Jia Horng        |                        |   |                   |   |  |   |   |       |   |       |   |   |   |
| Vice President | Liu Yun Ping          |                        |   |                   |   |  |   |   |       |   |       |   |   |   |
| Vice President | Teng Chun I (Note 6)  |                        |   |                   |   |  |   |   |       |   |       |   |   |   |
| Vice President | Lee Mei Huei (Note 9) |                        |   |                   |   |  |   |   |       |   |       |   |   |   |

| Range of Remuneration            | Name of Presidents and Vice Presidents |  |
|----------------------------------|--|--|
|                                  | The Company                            | Companies in the consolidated financial statements |
| Under NT\$ 1,000,000             |  |  |
| NT\$1,000,001 ~ NT\$2,000,000    | Teng Chun I                            | Teng Chun I  |
| NT\$2,000,001 ~ NT\$3,000,000    |  |  |
| NT\$3,000,001 ~ NT\$4,000,000    | Lee Mei Huei                           | Lee Mei Huei                                       |
| NT\$4,000,001 ~ NT\$5,000,000    | Liu Yun Ping                           | Liu Yun Ping                                       |
| NT\$5,000,001 ~ NT\$10,000,000   | Chuo Chun Hung, Shyu Jia Horng         | Chuo Chun Hung, Shyu Jia Horng                     |
| NT\$10,000,001 ~ NT\$15,000,000  |  |  |
| NT\$15,000,001 ~ NT\$30,000,000  |  |  |
| NT\$30,000,001 ~ NT\$50,000,000  |  |  |
| NT\$50,000,001 ~ NT\$100,000,000 |  |  |
| Over NT\$ 100,000,000            |  |  |
| Total                            | 5                                      | 5  |

Note 1: It refers to the salaries, job allowances, severance pay for the general manager and deputy general managers in 2020.

Note 2: It refers to a variety of award bonuses, incentives, traffic allowances, special expenditures, various allowances, dormitory fares, provision of vehicles and such objects in kind and other remunerations provided to the general manager and deputy general managers in 2020. Besides, such salary expenses, including employee stock option certificates acquired by employees as "shares-based payments" under IFRS 2, including acquired employee stock option certificates, new shares with restricted employee interests and participation in subscription to new shares through capital increase through cash injection should be counted into the remuneration as well.

Note 3: The amount of employee remunerations proposed to be allocated to the general manager and vice presidents (including stocks and cash) for 2020 based on the actual allocation ratio in 2019.

Note 4: It refers to the aggregate total of all sorts of remunerations paid by all companies covered within the Consolidated Financial Statements (including the Company itself) to the Company's general manager and deputy general managers.

Note 5: It refers to the net profit after tax under indescribable financial statements of 2020.

Note 6: Vice President Teng Chun I of the Research and Development Center resigned on February 29, 2020.

### 3. Names of the managerial officers allocated with remuneration to employees and performance in allocation.

As of 2020/12/31 Unit: NT\$ thousands; shares

|         | Title                                  | Name                 | Employee Bonus - in Stock (Fair Market Value) | Employee Bonus - in Cash | Total      | Ratio of Total Amount to Net Income (%) |
|---------|--|----------------------|---|--------------------------|------------|---|
| Manager | President                              | Chuo Chun Hung       | 0   | 18,750,000               | 18,750,000 | 3.18%                                   |
|         | President                              | Shyu Jia Horng       |   |                          |            |   |
|         | Vice President of Marketing Center     | Hung Dong Chang      |   |                          |            |   |
|         | Vice President of R&D Center           | Liu Yun Ping         |   |                          |            |   |
|         | Vice President of R&D Center           | Teng Chun I (Note 2) |   |                          |            |   |
|         | Vice President of Manufacturing Center | Chen Chun Hsiung     |   |                          |            |   |
|         | Vice President of Division of Finance  | Lee Mei Huei         |   |                          |            |   |

Note 1: The remuneration to employees allocated to managerial officers anticipated for 2020 based on the actual allocation ratio of 2019.

Note 2: Vice President Teng Chun I of the Research and Development Center resigned on February 29, 2020.

#### 3.2.4 Comparison of Remuneration for Directors, Supervisors, Presidents and Vice Presidents in the Most Recent Two Fiscal Years and Remuneration Policy for Directors, Supervisors, Presidents and Vice Presidents

- The ratio of the total amount of remuneration paid to the directors and supervisors of the company and all the companies in the consolidated financial statements in the recent two years in the net profit after tax.

|                              | 2019 Total Amount of Remunerations<br>The ratio of net profit after tax for the current year |   | 2020 Total Amount of Remunerations<br>The ratio of net profit after tax for the current year |   |
|------------------------------|--|---|--|---|
|                              | The Company  | All companies included in the consolidated statements | The Company  | All companies included in the consolidated statements |
| Director                     | 2.43%  | 2.43%   | 2.50%  | 2.50%   |
| President and Vice President | 5.69%  | 5.69%   | 4.04%  | 4.04%   |

- B. Description and Analysis (Refer to Pages 16~17 of the list of remunerations for

directors, GM, and Vice President.

- (1) Remunerations paid to directors are in accordance with the provisions in the “Company Charter.” If the company incurs profits in the current year, 3%~15% of the profits should be designated as remunerations for employees and no more than 3% of remunerations for directors. In addition to transportation fees for regularly attending meetings, remunerations paid are based on the periodically completed annual board performance assessment results of the “Board Performance Assessment Guidelines” and are in reference to the company’s annual overall business performance (performance assessment results of excellence for both 2020 and 2019), which will be reported to the Remunerations Committee and board for review and approval in accordance with the “Remuneration Committee Organization Provisions” before remuneration distribution. In addition, the Remuneration Committee shall periodically review the reasonability of the remuneration policy, system, standard, and structure; the amounts paid in 2020 and 2019 were \$3,500,000 and \$3,500,000 respectively, not exceeding the upper limit. The amounts were deemed reasonable in relation to the board’s annual performance assessment results and operational performance; the “expenses for performing business” referred to transportation fees for attending meetings, accounting for \$980,000 in 2020 and \$1,040,000 in 2019.
- (2) The standards of remunerations granted to the general manager, vice general managers and managerial officers (including salaries, incentive awards and remuneration to employees) are first proposed by the Human Resources Department pursuant to the scopes of their duties and responsibilities in accordance with the Managerial Regulations “Regulations Governing Management over Position Titles”; “Managerial Rules over Salaries”; “Organizational Rules of Remuneration Committee” with reference to the rates prevalent in the counterpart peers in the same industry into the rational remuneration structures which were, in turn, submitted to the Remuneration Committee and Board of Directors for resolutions after deliberation process. The incentive awards and remuneration to employees were determined based on the personal KPI performance accomplishment rates, and contribution degree toward the performance indicators, submitted to the Remuneration Committee for final decisions. Moreover, the Remuneration Committee further checks and reviews the remuneration policies, systems, standards/criteria structure to check and make sure of the rationality. The remunerations granted to the general manager, vice general managers and managerial officers in 2020 and 2019 were found without a significant gap and prove rational when compared with the Company’s annual business performance.

### 3.3 Implementation of Corporate Governance

#### 3.3.1 Board of Directors

The Board called 7 (A) meetings in 2020. The attendance of directors is specified as follows:

| Title                | Name   | Attendance in Person (B) | By Proxy | Attendance Rate (%) 【 B/A 】       | Remarks  |
|----------------------|--|--------------------------|----------|-----------------------------------|--|
| Chairman             | Lam Tai Seng   | 7                        | 0        | 100 %<br>(Required attendance: 7) | Re-elected (Re-election date: June 8 <sup>th</sup> , 2018) |
| Director             | Liu Chiu Tsao  | 7                        | 0        | 100 %<br>(Required attendance: 7) | Re-elected (Re-election date: June 8 <sup>th</sup> , 2018) |
| Director             | Wang Wei Wei   | 7                        | 0        | 88 %<br>(Required attendance: 7)  | Re-elected (Re-election date: June 8 <sup>th</sup> , 2018) |
| Director             | Representative of Yi Hua Investment : Liaw Jui Tsung | 7                        | 0        | 100 %<br>(Required attendance: 7) | New elect (Re-election date: June 8 <sup>th</sup> , 2018)  |
| Independent director | Chen Kuo Hong  | 7                        | 0        | 100 %<br>(Required attendance: 7) | Re-elected (Re-election date: June 8 <sup>th</sup> , 2018) |
| Independent director | Hsieh Han Chang                                      | 7                        | 0        | 100 %<br>(Required attendance: 7) | Re-elected (Re-election date: June 8 <sup>th</sup> , 2018) |
| Independent director | Liang Wei Ming                                       | 7                        | 0        | 100 %<br>(Required attendance: 7) | New elect (date of election: June 12 <sup>th</sup> , 2019) |

Other mentionable items:

- If any of the following circumstances occur, the date of the meetings, sessions, contents of motion, all independent directors' opinions and the company's response should be specified:

(1) Matters referred to in Article 14-3 of the Securities and Exchange Act.

| Board of Directors   | Details of the relevant agendas and the subsequent   | Issues listed in the Securities and Exchange Act, Article 14, Part 3 | Independent directors opposed or reserved their opinion |
|--|--|--|---|
| 2020.3.19<br>11 <sup>th</sup> Board of Directors<br>14 <sup>th</sup> Meeting | Pass of the partial amendment to the Company's internal control system financing circulation "Managerial Operation Subject to International Accounting Standards."                                 | V  | None  |
|  | Company's response to independent director's opinion: not applicable<br>Resolution results: After inquiries made by the chairman, consent and approval were obtained by all the directors present. |  |   |



| Board of Directors   | Details of the relevant agendas and the subsequent  | Issues listed in the Securities and Exchange Act, Article 14, Part 3 | Independent directors opposed or reserved their opinion |
|--|---|--|---|
| 2020.5.7<br>11 <sup>th</sup> Board of Directors<br>15 <sup>th</sup> Meeting  | Passing the 2020 Financial Statement Auditor expenses case (Reviewed and passed by the Audit Committee review on 2020/5/7)<br><br>Company's response to independent director's opinion: not applicable<br><br>Resolution results: After inquiries made by the chairman, consent and approval were obtained by all the directors present.  | V  | None  |
| 2020.8.16<br>11 <sup>th</sup> Board of Directors<br>17 <sup>th</sup> Meeting | Passed the "Subsidiary Box Technologies Limited applying for GBP \$2million credit line with 100% guarantee at Changhua Commercial Bank" case (reviewed and passed by the Audit Committee on 2020/8/16) and authorized the chairman to handle contract related matters.<br><br>Company's response to independent director's opinion: not applicable<br><br>Resolution results: After inquiries made by the chairman, consent and approval were obtained by all the directors present. | V  | None  |

(2) In addition to the aforementioned matters, other matters resolved by the board opposed or retained by other independent directors with records or written declarations: None.

2. The avoidance of the conflict of interest by the Directors on related motions, specify the names of the Independent Directors, the content of the motions, the principle of the avoidance of the conflict of interest, and the participation in casting the ballots: None.

## 3. Director Assessment Implementation Situation

|                    |   |
|--------------------|---|
| Assessment Cycle   | <p>The Company officially enacted in 2017 “Regulations Governing Evaluation of Performance by the Board of Directors” containing highlights including notably the period frequency and timing of evaluation, scope of evaluation, unit of execution, evaluation process, instruction guide on evaluation indicators. Accordingly, the General Manager Office (the unit in charge of execution) conducts the performance evaluation on an annual basis. Further at the end of every year, the General Manager Office produces the self-evaluation questionnaires to help the directors and functional committees to conduct self-evaluation before they assemble the reports and offer the report to the board of directors meeting convened in the first quarter of the ensuing year. In the report process, they would review and ascertain the key plans to further enhance the functional performance.</p> <p>The 2020 self-assessment results are rated excellent and were reported at the board meeting on March 18, 2021.</p> |
| Assessment Period  | The 2020 board performance (January 1, 2020 to December 31, 2020) was assessed.   |
| Assessment Scope   | The board, individual board members, Audit Committee, and Remuneration Committee.   |
| Assessment Method  | The board internal self-assessment, board member self-Assessment, Audit Committee member self-assessment, Remuneration Committee member self-assessment   |
| Assessment Content | <p>(1) Board performance assessment indicators include five aspects:<br/>The degree of participation in company operations, board decision-making quality, board makeup and structure, director election, training, internal control.</p> <p>(2) Individual board member performance assessment indicators include six aspects:<br/>Grasp of company goals and missions, recognition of Director duties, degree of participation in company operations, internal relations management and communication, director professionalism and training, internal control.</p> <p>(3) Functional Committee (Audit Committee and Remunerations Committee) performance assessment indicators include five aspects:<br/>Degree of participation in company operations, recognition of duties of Functional Committee, improvement of Functional Committee decision-making quality, Functional Committee makeup and member election, internal control.</p>   |

4. Evaluate goals and status of strengthening the board's job functions in the past few years:

- (1) The Company set up two independent directors starting from 2002 and increased one more independent director in 2018. Here at the Company under the Board of Directors, there is the Audit Committee and Remuneration Committee. The Audit Committee (organized in 2018) was organized by three independent directors and the Remuneration Committee (organized in 2011) was organized by two independent directors and one expert. The organizational rules of all functional committees have been duly approved by the Board of Directors.
- (2) In an attempt to enhance the function and efficiency of the Board of Directors, the Company officially enacted the "Regulations Governing Evaluation of the Performance by the Board of Directors" in 2017. Accordingly, the performance by the Board of Directors is evaluated at end of every fiscal year. In the evaluation process, the General Manager Office first collects the Board of Directors activities related information to work out the questionnaires accordingly and distributes the questionnaires to all directors and all functional committees, assembles the self-evaluation outcome and creates the report which is delivered to the board of directors meeting convened in the first quarter of the ensuing year.
- (3) To thoroughly implement corporate governance, the Company set the corporate governance head in 2019 to assume the responsibility to provide the directors with all information and data required for performance of duty and law compliance and further arrange continuing education programs to help the Board of Directors fulfill their responsibilities and powers well.
- (4) The Company's Board of Directors faithfully complies with the "Rules of Procedures Governing Board of Directors Meeting" where both the Auditor Head and Financial Head shall attend as guest participants. In a board of directors meeting, the directors shall, other than discussing the motions within the agenda, request the management level to report on the Company's business performance, market analyses, business strategy, product layout, managerial operation, human resources, financial data, operation by the respective departments on a regular basis so as to oversee the management teams to faithfully fulfill their duties and responsibilities.

### 3.3.2 Implementation of the Audit Committee or supervisors' participating in the operation of the Board of Directors:

The Auditing Committee convened for 4 times (A) in 2020. The attendance of the independent directors is shown below:

| Title                | Name            | Actual number of attendance (B) | Attend through proxy | Percentage of actual attendance (%) [B/A] | Note   |
|----------------------|-----------------|---------------------------------|----------------------|---|--|
| Independent director | Chen Kuo Hong   | 4                               | 0                    | 100 %<br>(Required attendance: 4)         | Re-elected (Re-election date: June 8 <sup>th</sup> , 2018) |
| Independent director | Hsieh Han Chang | 4                               | 0                    | 100 %<br>(Required attendance: 4)         | Re-elected (Re-election date: June 8 <sup>th</sup> , 2018) |
| Independent director | Liang Wei Ming  | 4                               | 0                    | 100 %<br>(Required attendance: 4)         | New elect (date of election: June 12 <sup>th</sup> , 2019) |

Other mentionable items:

- For the operation of the Audit Committee in any of the following circumstances, please specify the date, term, the contents of the proposals, the resolution of the Audit Committee, and the process of the opinions proposed by the Audit Committee:

(1) Matters referred to in Article 14-5 of the Securities and Exchange Act.

| Audit Committee  | Details of the relevant agendas and the subsequent  | Independent directors opposed or reserved their opinion |
|--|---|---|
| 2020.3.19<br>1 <sup>st</sup> Board of Directors 8 <sup>th</sup> Meeting  | 1. Passed the 2019 financial statement (including consolidate ate dinner financial statement)<br>2. Passed the 2019 "Internal Control System Announcement", which deems effective the company's Internal Control System Design<br>3. Pass of the partial amendment to the Company's internal control system financing circulation "Managerial Operation Subject to International Accounting Standards." | None  |
|  | Company's response to independent director's opinion: not applicable<br>Resolution: Passed by all the independent directors present.  |   |
| 2020.5.7<br>1 <sup>st</sup> Board of Directors 9 <sup>th</sup> Meeting   | 1. Passing the 2020 Financial Statement Auditor expenses case<br>2. Passed the financial statement CPA independence assessment case.  | None  |
|  | Company's response to independent director's opinion: not applicable<br>Resolution: Passed by all the independent directors present.  |   |
| 2020.8.06<br>1 <sup>st</sup> Board of Directors 10 <sup>th</sup> Meeting | 1. Passed the "Subsidiary Box Technologies Limited applying for GBP \$2million credit line with 100% guarantee at Changhua Commercial Bank" case.   | None  |
|  | Company's response to independent director's opinion: not applicable<br>Resolution: Passed by all the independent directors present.  |   |

- (2) In addition to the aforementioned motions, other motions without approval by the Auditing Committee but passed by the Board with 2/3 of the Directors: None.

2. With respect to the avoidance of conflicting interest agendas, describe the names of independent directors, details of the relevant agendas, reasons for avoiding conflicting interest, and the voting decisions: None.
3. Performance of communications by and between independent directors, audit head and Certified Public Accountant(s) (should include the Company's financial, business operation affairs, issued, methods and outcomes of communications among them).

The company's Audit Committee is made up of three independent directors. The internal audit supervisors and financial statement CPAs assist independent directors in fulfilling their duties and urging the board to engage in more effective operations through the following communication meetings:

- (1) Here at the Company, the internal audit head shall join a meeting with the independent directors in the Audit Committee at least on a quarterly basis. The contents of communications shall include performance of the internal audit and key issues linked up with business operation. In case of an extraordinary circumstance, the internal audit head shall report to the independent directors in the Audit Committee in real time. In 2020, there was not any extraordinary circumstance as mentioned above. The Company's internal audit head has been in very close and sound communications with the Audit Committee.
- (2) The Company's certified public accountants would, after completing the review process of the Company's financial statements, hold a symposium with the directors to explain the audit opinions, findings in the auditing over the internal control system, updates of major laws and proposals on countermeasures. In case of an extraordinary circumstance, the certified public accountants shall report to the independent directors in the Audit Committee in real time. In 2020, there was not any extraordinary circumstance as mentioned above. The certified public accountants have been in very close and sound communications with the Audit Committee.

Communication between Independent Directors and internal audit officers and CPA:

| Date      | Summary of Talks  |
|-----------|---|
| 2020.3.19 | <p>8 meetings were convened by the first Audit Committee. The communication matters and results are as follows:</p> <ol style="list-style-type: none"> <li>1. The audit supervisor reported the summary of the actual audit for 2019.</li> <li>2. The audit supervisors repurposed the declaration of the 2019 internal control self-assessment results and internal control system.</li> <li>3. The chief audit executive reported on the company's internal audit from Dec. 2019 to February of 2020.</li> <li>4. The audit head explains the partial amendments to the "Internal Control Financing Circulation would subject to 'International Accounting Standards (IAS),' "Articles of Incorporation," "Ethical Corporate Management Best-Practice Principles," "Best-Practice Principles on Good Faith Management and Ethic Act Guide," "Rules of Procedures Governing Board of Directors Meeting," "Shareholders' Meeting Procedure Rules."</li> <li>5. The Audit Head helps the General Manager' Office with the consolidated report as enumerated below: In 2019, the Board of Directors was evaluated in "good" in performance; the Company did not show anything abnormal in its Ethical Corporate Management Best-Practice Principles; the Company showed no abnormality in implementation of corporate social responsibility (CSR) or in communications with stakeholders; and the Company showed no abnormality in management over information security.</li> <li>6. The certified public accountants reported the audit of the consolidated and individual financial statements in 2019, their communications with the Company as well as their interchange and communications with the corporate governance department and with the independent directors.</li> </ol> <p>Opinion of independent director: None.</p> |

| Date  | Summary of Talks   |
|---|--|
| 2020.5.7  | <p>9 meetings were convened by the first Audit Committee. The communication matters and results are as follows:</p> <ol style="list-style-type: none"> <li>1. The chief audit executive reported on the company's internal audit from March to April of 2020.</li> <li>2. The chief audit executive reported on the improvements to the flaws in 2019's internal control system and unusual affairs</li> <li>3. The Audit Head explains the partial amendment to the "Operating Regulations of the Offense-Reporting System" and "Corporate Social Responsibility (CSR)."</li> </ol> <p>Opinion of independent director: None.</p>   |
| 2020.8.6  | <p>10 meetings were convened by the first Audit Committee. The communication matters and results are as follows:</p> <ol style="list-style-type: none"> <li>1. The chief audit executive reported on the company's internal audit from May to July of 2020.</li> <li>2. The Audit Head reported about the Company's subsidiary Box Technologies Limited that to meet its need to expand European markets, the subsidiary applies to Chang Hwa Commercial Bank for credit line amounting to GBP2 million</li> <li>4. The audit supervisor explained the "annual bank credit line renewal" case.</li> </ol> <p>Opinion of independent director: None.</p>  |
| 2020.11.5   | <p>11 meetings were convened by the first Audit Committee. The communication matters and results are as follows:</p> <ol style="list-style-type: none"> <li>1. The chief audit executive reported on the company's internal audit from August to October of 2020.</li> <li>2. The Audit Head reports about the plans scheduled for audit in 2021.</li> <li>3. The Audit Head helps the General Manager Office with the planning for management over intellectual property and the implementation in 2020.</li> <li>4. The Audit Head reports about formulation process of the "Risk Management Policy and Regulations Governing of Management thereof."</li> </ol> <p>Opinion of independent director: None.</p> |
| <p>All independent directors responded with no objection at all in response to the aforementioned issues.</p> |  |

(3) The annual work focuses of the company's Audit Committee are as follows:

- Review the establishment or review the public offering, issuance, or private placement of equity-type securities.
- Review the appointment, dismissal, or compensation of the CPAs.
- Review CPA independence and performance assessments.
- Appointment and dismissal of the Finance Officer, Accounting Officer, or Internal Chief Auditor.
- Review the Annual financial reports and interim financial report.
- Review audit plans and reports.
- Review the integrity operation system and implementation results.
- Audit Committee self-assessment of performance
- Review other significant matters required by the Company or the competent authorities
- vision of the internal control system.
- Evaluate the effectiveness of the internal control system.
- Review the Procedures for the Acquisition and Disposal of Assets, the trade of derivatives, loaning of funds, making of endorsement/guarantees or amended
- Review matters that involve the best interests of the directors.
- Review material assets or derivative transactions.
- Review the lending, endorsement, or guarantee of capital in huge sum.

### 3.3.3 Corporate Governance Implementation Status and Deviations from “the Corporate Governance Best-Practice Principles for TWSE/TPEX Listed Companies”

| Evaluation Item   | Implementation Status |    |  | Deviations from “the Corporate Governance Best-Practice Principles for TWSE/TPEX Listed Companies” and Reasons |
|---|-----------------------|----|--|--|
|   | Yes                   | No | Abstract Illustration  |  |
| 1.Does the company establish and disclose the Corporate Governance Best-Practice Principles based on “Corporate Governance Best-Practice Principles for TWSE/TPEX Listed Companies”?  | V                     |    | The Company has established the Corporate Governance Best-Practice Principles based on “Corporate Governance Best-Practice Principles for TWSE/TPEX Listed Companies” on May 2015. The information has been disclosed on the Company’s website.  | None   |
| 2.Shareholding structure & shareholders’ rights<br>(1) Does the company establish an internal operating procedure to deal with shareholders’ suggestions, doubts, disputes and litigations, and implement based on the procedure?<br>(2) Does the company possess the list of its major shareholders as well as the ultimate owners of those shares?<br>(3) Does the company establish and execute the risk management and firewall system within its conglomerate structure?<br>(4) Does the company establish internal rules against insiders trading with undisclosed information? | V                     |    | (1) In addition to the existing hotline and email channels, the Company has established an internal operating procedure, and has designated appropriate departments, such as spokesman, deputy spokesman, investor Relations, to handle shareholders’ suggestions, doubts, disputes and litigation.<br>(2) The Finance & Shared Services Division is responsible for collecting the updated information of major shareholders and the list of ultimate owners of those shares.<br>(3) The company has created the Regulations for Transactions among Stakeholding Corporate Groups and Specific Companies, the Regulations for Company-Invested Enterprises, internal control’s Supervision and Management of Subsidiary Companies, the Regulations for Transactions Between Stakeholders, and other relevant management standards, in which we clearly specify and regulate management authority and control methods among companies with connected interests. Moreover, we can supervise our subsidiaries as they establish and carry out necessary internal control systems, and as they build good risk-control systems and firewalls in compliance with our Company Governance Principles<br>(4) The company has made the following management regulations<br>(A) The Ethical Management Principles and the Company Ethical Behavior Principles, which stipulate that internal personnel should not take advantage of unpublicized information and engage in insider trading or disclose information to others so they can engage in insider trading. | None   |

| Evaluation Item  | Implementation Status |    |   | Deviations from “the Corporate Governance Best-Practice Principles for TWSE/TPEX Listed Companies” and Reasons |
|--|-----------------------|----|---|--|
|  | Yes                   | No | Abstract Illustration   |  |
|  |                       |    | <p>(B) The Procedures for Handling Major Internal News state that internal personnel aware of major internal news should not disclose the information to others.</p> <p>The above regulations are all compliant with our Company Governance Principles.</p> <p>(1)~(4) above were implemented in 2020 as provisioned.</p>   |  |
| <p>3.Composition and Responsibilities of the Board of Directors</p> <p>(1) Does the Board develop and implement a diversified policy for the composition of its members?</p> | V                     |    | <p>(1) The company made its Company Governance Principles based on the Corporate Governance Best Practice Principles for TWSE/TPEX-Listed Companies. In these principles, below the strengthening of the board’s job functions part, is a regulation that reads, “the Board of Directors should consist of a diverse group of members. The company’s operations, management models and development needs should embrace a principle of diversity that shall include but not be limited to two major aspects: (I) Basic personal information and values: gender, age, nationality, and cultural background; (II) Expertise and skills: specialized background (such as law, accounting, industry, finance, sales, or technology), specialized skills, industry experience, etc.”</p> <p>The company board’s diversified and specific goal achievement situations are explained below:</p> <p>(A) Gender goal: Female directors accounting for 25% of all the directors (or two seats).</p> <p>Achievement situations: The company elected one female director in 2018, accounting for 14%. The company will continue to work on this part.</p> <p>(B) Age goal: Those below age 60 accounting for 30%.</p> <p>Achievement situation: Two directors are under age 60, and the other five are aged 60~65. The company will continue to work on this part.</p> <p>(C) Education/work goal: higher than master’s degree holders or professional managers of TAIEX and OTC listed companies.</p> <p>Achievement situation: One doctorate degree holder and five</p> | None.  |



| Evaluation Item | Implementation Status |    |  | Deviations from “the Corporate Governance Best-Practice Principles for TWSE/TPEx Listed Companies” and Reasons |
|-----------------|-----------------------|----|--|--|
|                 | Yes                   | No | Abstract Illustration  |  |
|                 |                       |    | <p>master’s degree holders. External directors are all professional managers concurrently or formerly working at TAIEX and OTC listed companies.</p> <p>(D) Professional goal: Operational judgment ability, accounting and financial analysis ability, operational management ability, crisis handling ability, industrial knowledge, international market outlook, leadership, decision-making ability.</p> <p>Achievement situation: The backgrounds of the directors are as shown in the following table. The goal of diversified complementariness has been achieved.</p> |  |

| Diversification Core Projects | Specialized Background                          | Gender | Operating judgment | Accounting and Finance Analysis Skills | Operational and Management Ability | Crisis Response Ability | Industry Experience |             |            | Understanding of International Markets | Leadership | Decision Making |
|-------------------------------|---|--------|--------------------|--|------------------------------------|-------------------------|---------------------|-------------|------------|--|------------|-----------------|
|                               |   |        |                    |  |                                    |                         | Computer            | Electronics | Investment |  |            |                 |
| Name of Director              |   |        |                    |  |                                    |                         |                     |             |            |  |            |                 |
| Lam Tai Seng                  | Industry, Technology, Sales, Management         | Male   | √                  |  | √                                  | √                       | √                   | √           |            | √                                      | √          | √               |
| Wang Wei Wei                  | Sales, Finance, Design, Management              | Female | √                  | √                                      | √                                  | √                       | √                   |             | √          | √                                      | √          | √               |
| Liu Chiu Tsao                 | Industry, Technology, Sales, Management         | Male   | √                  | √                                      | √                                  | √                       | √                   | √           |            | √                                      | √          | √               |
| Liaw Jui Tsung                | Industry, Technology, Manufacturing, Management | Male   | √                  | √                                      | √                                  | √                       | √                   | √           |            | √                                      | √          | √               |
| Chen Kuo Hong                 | Industry, Technology, Sales, Management         | Male   | √                  |  | √                                  | √                       |                     | √           | √          | √                                      | √          | √               |
| Hsieh Han Chang               | Industry, Finance, Sales, Management            | Male   | √                  | √                                      | √                                  | √                       |                     | √           | √          | √                                      | √          | √               |
| Liang Wei Ming                | Industry, Technology, Sales, Management         | Male   | √                  |  | √                                  | √                       | √                   | √           |            | √                                      | √          | √               |

| Evaluation Item  | Implementation Status |    |  | Deviations from “the Corporate Governance Best-Practice Principles for TWSE/TPEx Listed Companies” and Reasons |
|--|-----------------------|----|--|--|
|  | Yes                   | No | Abstract Illustration  |  |
| <p>(2) Does the company voluntarily establish other functional committees in addition to the Remuneration Committee and the Audit Committee?</p> <p>(3) Does the company set board performance assessment guidelines and the assessment method? Is a performance assessment periodically carried out each year, and are the performance assessment results reported to the board as a reference for remunerations of individual directors and re-election nominations?</p> |                       |    | <p>(2) The company has established the following functional committee</p> <p>(A) In October 2011, the company set up the Remuneration Committee and established the Organizational Protocols of the Remuneration Committee by which the committee will be guided.</p> <p>(B) The Audit Committee was set up in June 2018 and the “Organizational Regulations for the Audit Committee” was formulated and implemented in accordance with the regulations.</p> <p>(3) The company passed the “board assessment guidelines” on March 29, 2017, including assessment cycle and period, assessment scope, implementation unit, assessment procedure, and assessment indicators. The General Manager’s Office (implementation unit) implements a performance assessment once a year according to the guidelines and reports and summarizes assessment results at the board meeting in the first quarter the following year. The assessment indicators and implementation method are as follows:</p> <p>(A) Evaluation criteria for the board include level of participation in the company’s operations, improvement in the board’s decision making, organization and structure of the board, election of directors, continued education, internal control, etc.</p> <p>(B) Evaluation criteria for board members include mastery of the company’s goals and tasks, knowledge of director’s job responsibilities, level of participation in the company’s operations, management of internal relationships and communication, expertise, continued education of directors, internal control, etc.</p> <p>(C) The designated implementation unit General Manager’s office is responsible for conducting a performance assessment on the board and individual directors from the end of year to early the following year. The performance assessment results are</p> |  |

| Evaluation Item  | Implementation Status |    |  | Deviations from “the Corporate Governance Best-Practice Principles for TWSE/TPEX Listed Companies” and Reasons |
|--|-----------------------|----|--|--|
|  | Yes                   | No | Abstract Illustration  |  |
| (4) Does the company regularly evaluate the independence of CPAs?  |                       |    | <p>reported to the board in the first quarter to review items for improvement and discuss the function strengthening improvement plan as a reference for remunerations of individual directors and re-election nominations.</p> <p>The 2020 assessment results of the performance of all the directors and the overall performance of the board were excellent, which were reported to the board on March 18, 2021.</p> <p>(4) During the board meeting on May 7, 2020, according to the Statement of Independence made by Shih Wei Ming and Wang Yung-Sheng from KPMG Taiwan, the company audited the following items in order to evaluate the accountants' independence. All directors agreed that there were no violations and that accountants auditing the company's financial report were sufficiently objective and independent:</p> <p>(A) Whether the service provided by the accountants violate the terms of independence</p> <p>(B) Whether the audit of the company's financial reports and the quality of verification are accurate and professional</p> <p>(C) Whether the accountants have major exchange of interests or financing guarantees with the company's clients, directors, or supervisors</p> <p>(1)~(4) above were implemented in 2020 as provisioned.</p> |  |
| 4.Does the company allocated an appropriate number of competent corporate governance staff members, has it designated a corporate governance supervisor responsible for corporate governance related matters (including but not limited to information required by directors and supervisors for business operations), matters at board and shareholders' meetings conducted in accordance with the law, production of board and shareholders' meeting proceedings, etc.)? | V                     |    | <p>Here at the Company, the General Manager Office teams up with the Management Center to jointly organize the “Sustainable Management Task Force” to assume the responsibility of carrying out corporate governance. The “Sustainable Management Task Force” is one of the five branch task forces under the “Corporate Social Responsibility Committee.” Vice General Manager Li of the Management Center concurrently serves as the Corporate Governance Head to oversee the members to help the Board of Directors faithfully carry out their duties. The responsibilities and powers and key issues of implementation as well as continued refresher programs in 2020 are as enumerated below:</p>  | None   |

| Evaluation Item | Implementation Status |    |  | Deviations from “the Corporate Governance Best-Practice Principles for TWSE/TPEx Listed Companies” and Reasons |
|-----------------|-----------------------|----|--|--|
|                 | Yes                   | No | Abstract Illustration  |  |
|                 |                       |    | <p>Corporate governance supervisor’s authority</p> <p>(A) Conducted board of director meetings and shareholder meetings in accordance with the law.</p> <p>(B) Produced board of directors and shareholders' meeting records and handle the application/revisions to the company’s registration certificate.</p> <p>(C) Assisted directors in their appointment and continued education.</p> <p>(D) Provided the information required by the directors to conduct business</p> <p>(E) Assisted directors to comply with the law</p> <p>(F) Handle matters stipulated in the company's articles of association or contracts</p> <p>(G) Arranged meetings between directors, internal auditors, and auditing accountants</p> <p>(H) Arranged meetings between the board and leaders of the company’s business branches to better understand the company</p> <p>(I) Followed legislation updates relevant to the company’s operations and governance</p> <p>(J) Supervise sustainable management implementation by members: Collect, formulate, and promote corporate governance related policies.</p> <p>2020 Performances</p> <p>(A) Assisted all directors in performing their duties and provided information required by the directors. This included: board meeting information, updates to the laws and regulations for business operation and corporate governance, important company information, and quarterly general manager business performance reports.</p> <p>(B) Developed and revised company policies or management regulations related to corporate governance.</p> |  |

| Evaluation Item  | Implementation Status                          |   |   | Deviations from “the Corporate Governance Best-Practice Principles for TWSE/TPEx Listed Companies” and Reasons |               |           |             |                |            |  |   |   |            |   |   |            |                                |   |   |
|--|--|---|---|--|---------------|-----------|-------------|----------------|------------|--|---|---|------------|---|---|------------|--------------------------------|---|---|
|  | Yes  | No  | Abstract Illustration   |  |               |           |             |                |            |  |   |   |            |   |   |            |                                |   |   |
|  |  |   | (C) Arranged all directors to complete six hours of educational training<br>(D) Arranged for meetings between directors and chief audit executive and auditors.<br>(E) Arranged for meetings between the company’s various managers, subsidiary owners and the board of directors.<br>(F) Conducted board meetings and shareholder meetings by providing meeting notices, calls, meeting materials, and making agendas in accordance with laws and regulations.<br>(G) Tracked the completion of proposals after board meetings and shareholder meetings.<br>(H) Handled uploading the information from the shareholder meetings and the company registration certificate in accordance with the law.<br>The 2020 training situations are as follows: |  |               |           |             |                |            |  |   |   |            |   |   |            |                                |   |   |
| <table border="1" style="width: 100%; border-collapse: collapse;"> <thead> <tr> <th style="width: 15%;">Training date</th> <th style="width: 20%;">Organizer</th> <th style="width: 50%;">Course name</th> <th style="width: 15%;">Training hours</th> </tr> </thead> <tbody> <tr> <td>2020.08.17</td> <td rowspan="2">Accounting Research and Development Foundation</td> <td>The practical performance of enterprise corporate governance: Sound performance of the management to boost the managerial efficiency.</td> <td>3</td> </tr> <tr> <td>2020.11.09</td> <td>Analyses on the latest corporate governance policies and establishment of the “corporate governance personnel” to audit the hands-on performance of law compliance.</td> <td>6</td> </tr> <tr> <td>2020.09.08</td> <td>Securities &amp; Futures Institute</td> <td>How shall we innovate amidst the digital economic era and KPI performance management?</td> <td>3</td> </tr> </tbody> </table> |  |   |   |  | Training date | Organizer | Course name | Training hours | 2020.08.17 | Accounting Research and Development Foundation | The practical performance of enterprise corporate governance: Sound performance of the management to boost the managerial efficiency. | 3 | 2020.11.09 | Analyses on the latest corporate governance policies and establishment of the “corporate governance personnel” to audit the hands-on performance of law compliance. | 6 | 2020.09.08 | Securities & Futures Institute | How shall we innovate amidst the digital economic era and KPI performance management? | 3 |
| Training date  | Organizer                                      | Course name   | Training hours  |  |               |           |             |                |            |  |   |   |            |   |   |            |                                |   |   |
| 2020.08.17   | Accounting Research and Development Foundation | The practical performance of enterprise corporate governance: Sound performance of the management to boost the managerial efficiency.                               | 3   |  |               |           |             |                |            |  |   |   |            |   |   |            |                                |   |   |
| 2020.11.09   |  | Analyses on the latest corporate governance policies and establishment of the “corporate governance personnel” to audit the hands-on performance of law compliance. | 6   |  |               |           |             |                |            |  |   |   |            |   |   |            |                                |   |   |
| 2020.09.08   | Securities & Futures Institute                 | How shall we innovate amidst the digital economic era and KPI performance management?   | 3   |  |               |           |             |                |            |  |   |   |            |   |   |            |                                |   |   |
| 5.Does the company establish a communication channel and build a designated section on its website for stakeholders, as well as handle all the issues they care for in terms of  | V  |   | Here at the Company, we have set up the Stakeholders’ Special Zone on the Company’s website in both Chinese and English version ( <a href="http://www.flytech.com">http://www.flytech.com</a> ) where we duly provide the channels to the   | None.  |               |           |             |                |            |  |   |   |            |   |   |            |                                |   |   |

| Evaluation Item  | Implementation Status |    |   | Deviations from “the Corporate Governance Best-Practice Principles for TWSE/TPEx Listed Companies” and Reasons |
|--|-----------------------|----|---|--|
|  | Yes                   | No | Abstract Illustration   |  |
| corporate social responsibilities?   |                       |    | <p>stakeholders regarding the issues within their concern and contact means. Through continued interactions, we closely respond to the stakeholders’ requirements, expectation and concerns. In turn, we can reassess our internal management with feedback in response with concrete acts so as to thoroughly put into implementation responsible business management. Further, with the Company’s effort to compile the “Corporate Social Responsibility (CSR) Report” (with the initial issuance as CSR 2019) to look into stakeholders’ key concerns. Accordingly, we would elaborately map out business policies. Through follow-up evaluation &amp; appraisal process, we shall assure constant validity of the CSR as the very annual goal of our advancement.</p> <p>In 2020, the above tasks were verifiably implemented.</p>  |  |
| 6.Does the company appoint a professional shareholder service agency to deal with shareholder affairs?   | V                     |    | The Company designates Capital Securities Inc. to deal with shareholder affairs.  | None   |
| 7.Information Disclosure<br>(1) Does the company have a corporate website to disclose both financial standings and the status of corporate governance? | V                     |    | <p>(1) The Company has set up a Chinese/English website (www.flytech.com.tw) to disclose information regarding the Company’s financials, business and corporate governance status.</p> <p>The company has in place its Procedures for Handling Major Internal News, and the PR and accounting departments will organize news about company finances and operations, as well as about Results Conference Calls, which are legally required to be revealed for public knowledge. The news will then be sent by a spokesperson to the Market Observation Post System as well as the company’s corporate website (http://www.flytech.com). Important information about the company’s financial state and governance includes company governance, important regulations, board resolutions, communications between independent directors and internal auditors and accountants, internal control organization and operations, corporate social responsibility, implementation of ethical management, environmental and energy conservation policies, supplier management, employee benefits, specialized</p> | None   |

| Evaluation Item  | Implementation Status |    |   | Deviations from “the Corporate Governance Best-Practice Principles for TWSE/TPEx Listed Companies” and Reasons |
|--|-----------------------|----|---|--|
|  | Yes                   | No | Abstract Illustration   |  |
| <p>(2) Does the company have other information disclosure channels (e.g. building an English website, appointing designated people to handle information collection and disclosure, creating a spokesman system, webcasting investor conferences)?</p> <p>(3) Does the company announced and declared annual financial statements within two months after the end of the scouting year and announced and declared the financial statements for the first, second, and third quarter and the monthly operational situations in advance before the provisioned deadline?</p> |                       |    | <p>space for stakeholders, etc. In 2020, the above tasks were verifiably implemented.</p> <p>(2) Is the same as the description in (1).</p> <p>(3) The company announced and declared the financial statements for the first, second, and third quarter and the monthly operational situations in advance in 2020.</p>  |  |
| <p>8. Is there any other important information to facilitate a better understanding of the company’s corporate governance practices (e.g., including but not limited to employee rights, employee wellness, investor relations, supplier relations, rights of stakeholders, directors’ and supervisors’ training records, the implementation of risk management policies and risk evaluation measures, the implementation of customer relations policies, and purchasing insurance for directors and supervisors)?</p>   | V                     |    | <p>(1) Since our Company first came into being in 1984, we have, as always, adhered to the belief of “focus on our base industry, sustainable operation with pursuit toward excellence” to operate our enterprises. We have held the advantages of “complete products, advanced technology, excellent manufacturing and strong commitment from partners in full.” Our Company already obtained verified ISO 9001/13485 Quality Management System, ISO 14001 Environmental Management System, ISO 45001 Occupational Safety and Health Management System, and ISO 27001 Information Security System Certification. We have further set up the Company’s intellectual property management system exactly in accordance with the Ministry of Economic Affairs’ “Taiwan Intellectual Property Management Systems (TIPS)” providing high-quality products and services and sound protection of intellectual property rights. Further, under the philosophy of Ethical Corporate Best-Practice Principles, through risk management to set up a sound corporate governance environment, we have duly formulated: Internal control system, management regulations, accounting system, budget system, ISO Standard Operating Procedures, intellectual property management systems and risk control designs such as the MIS system which have been duly operated as hierarchically authorized by employees at respective levels to perform their own duties and operations. The</p> | None.  |

| Evaluation Item | Implementation Status |    |  | Deviations from “the Corporate Governance Best-Practice Principles for TWSE/TPEx Listed Companies” and Reasons |
|-----------------|-----------------------|----|--|--|
|                 | Yes                   | No | Abstract Illustration  |  |
|                 |                       |    | <p>Company’s Board of Directors and Audit Committee would perform the respective functions to check and balance.</p> <p>(2) Amidst our continued watchfulness over all sorts of potential risks either internally or externally that are likely to impact our business operation, we have duly set up appropriate managerial measures and countermeasures to render sound and accurate risk management toward out stakeholders. Thanks to such sound system, whenever an incident takes place, we can continually carry out our key business operation without interruption. Our “Risk Management Policy and Operating Rules” (including scope of risk management, policies of risk management, organization chart of risk management, powers and responsibilities in risk management, categories of risks, risk management PDCA flowcharts) were officially resolved by the Board of Directors on January 20, 2021. Accordingly, we have set up sound managerial framework and countermeasures against potential major risks.</p> <p>(3) The company has made the following management regulations related to company governance:</p> <p>(A) Company Governance Principles: Clearly stipulates systems and regulations that should be covered.</p> <p>(B) The company has set up the Code for Integrity Operations” and “Code for Moral Conduct” (passed by the board on May 12, 2015), the “Integrity Operation Procedure and Conduct Guidelines” (passed by the board on November 10, 2016), Guidelines for Transactions with Specific Companies and Stakeholders,” “Stakeholder Transaction Management Operation,” “Re-investment Company Operation Management Guidelines,” and related regulations and systems.</p> <p>These regulations stipulate moral principles that should be followed during exchanges among stakeholders, clients, suppliers, investors, employees, and other people of interest so that they can build harmonious and trust-based relationships.</p> <p>(C) Board Performance Evaluation Protocols: These protocols</p> |  |



| Evaluation Item | Implementation Status |    |   | Deviations from “the Corporate Governance Best-Practice Principles for TWSE/TPEx Listed Companies” and Reasons |
|-----------------|-----------------------|----|---|--|
|                 | Yes                   | No | Abstract Illustration   |  |
|                 |                       |    | <p>determine the evaluation cycle and time frame, evaluation range, executive units, evaluation processes, evaluation criteria, etc. Through periodical evaluation, we will continue to discuss how to improve the board’s functions.</p> <p>(4) The company has created the Employee Benefits Committee and the Labor Safety and Sanitation Committee, providing each employee with benefits and guarantees of safety and sanitation. In the company HR Guidelines, the committee also clearly defines employee behavior guidelines, job clearance, safety and sanitation, benefits/bonuses/penalties, raise evaluation, education/training, etc. The company offers employees a safe, steady, communicative, and excellent work environment.</p> <p>(5) The management of the company attaches great importance to corporate governance. During regular business meetings, they continue to pay attention to the system (division of powers and responsibilities, risk management, operating procedures, information transmission, etc.) and the effectiveness of actual operation and evaluation and adjustment. The directors will communicate it through the Board with management team and internal auditors to understand the company's governance operations and make suggestions.</p> <p>In 2020, the above tasks were verifiably implemented.</p> <p>The company has purchased liability insurance for all directors as of January 2020. We have also arranged periodic trainings and professional lessons that have to do with specific job responsibilities and company governance; the arrangement for 2020 is as follows:</p> |  |

| Evaluation Item                   |                 |               |               | Implementation Status  |   |                       | Deviations from “the Corporate Governance Best-Practice Principles for TWSE/TPEx Listed Companies” and Reasons |
|-----------------------------------|-----------------|---------------|---------------|--|---|-----------------------|--|
|                                   |                 |               |               | Yes  | No  | Abstract Illustration |  |
| Title                             | Name            | Election Date | Training date | Organizer  | Course name   | Training hours        | Compliance with Regulations  |
| Chairman                          | Lam Tai Seng    | 2018.06.08    | 2020.09.24    | Securities and Futures Institute                                     | The principle and application of blockchain   | 3                     | Yes  |
|                                   |                 |               | 2020.09.24    |  | Talking about how the Company should plan the equity from the recent cases of competition over the management powers              | 3                     | Yes  |
| Vice Chairman                     | Liu Chiu Tsao   | 2018.06.08    | 2020.08.06    | Corporate Governance Association                                     | Competition for management power with case analysis   | 3                     | Yes  |
|                                   |                 |               | 2020.10.14    | Securities and Futures Institute                                     | Probe into the Human Resources and M&A Integration Issues in the Process of Enterprise M&A  | 3                     | Yes  |
| Director                          | Wang Wei-wei    | 2018.06.08    | 2020.09.15    | Corporate Governance Association                                     | Practical Issues on Business Risk Management and Issues on Law Compliance   | 3                     | Yes  |
|                                   |                 |               | 2020.11.07    |  | The Latest Trends of Corporate Governance Evaluation Indicators that Directors and Supervisors Cannot Afford to Ignore            | 3                     | Yes  |
| Corporate Director representative | Liao Rui-cong   | 2018.06.08    | 2020.09.24    | Securities and Futures Institute                                     | The principle and application of blockchain   | 3                     | Yes  |
|                                   |                 |               | 2020.10.06    | Corporate Governance Association                                     | Trend of Taxation Management for the Group in the Post-COVID-19 Era   | 3                     | Yes  |
| Independent director              | Chen Kuo Hong   | 2018.06.08    | 2020.09.08    | Securities and Futures Institute                                     | How to Innovate KPI and Performance Management in the Digital Economic Era  | 3                     | Yes  |
|                                   |                 |               | 2020.09.08    |  | Probe into Legal Risks and Responses to the Directors and Supervisors from the Perspective of Major Enterprise Malpractice Cases  | 3                     | Yes  |
| Independent director              | Hsieh Han Chang | 2018.06.08    | 2020.03.17    | Chinese National Association of Industry and Commerce Taiwan (CNAIC) | Probe into the new thinking of group tax governance from the future taxation trend of digital taxation and international taxation | 3                     | Yes  |
|                                   |                 |               | 2020.09.24    |  | The up-to-date Securities Investors and Futures Traders Protection Act  | 3                     | Yes  |

| Evaluation Item      |                |            |            | Implementation Status            |   |                       | Deviations from “the Corporate Governance Best-Practice Principles for TWSE/TPEX Listed Companies” and Reasons |
|----------------------|----------------|------------|------------|----------------------------------|---|-----------------------|--|
|                      |                |            |            | Yes                              | No  | Abstract Illustration |  |
| Independent director | Liang Wei-Ming | 2019.06.12 | 2020.08.11 | Corporate Governance Association | The impact of the update Company Act upon directors & supervisors and shareholders                | 3                     | Yes  |
|                      |                |            | 2020.08.11 |                                  | Disclosure of the Company’s major Information and the Responsibility of Directors and Supervisors | 3                     | Yes  |

9. Please explain the improvements which have been made in accordance with the results of the Corporate Governance Evaluation System released by the Corporate Governance Center, Taiwan Stock Exchange, and provide the priority enhancement measures. The company has ranked 21%-35% in the corporate assessment for three consecutive years, advanced to 6%-20% from 5th~7th Evaluation , Among companies that have a market value between 5B NTD to 10B NTD, Flytech was ranked in top 5% in the 7th (2020) Evaluation, without improvement requirements from the competent authority. The company’s corporate governance promotion unit took the initiative to continue to make improvement on items without a score, including proceedings manual (English version), annual reports, etc. to strengthen information disclosure, complete the compilation of the 2019 “CSR Report”.

### 3.3.4 Composition, Responsibilities and Operations of the Remuneration Committee

#### 1. Professional Qualifications and Independence Analysis of Remuneration Committee Members

| Title                | Name            | Criteria | Meets One of the Following Professional Qualification Requirements, Together with at Least Five Years' Work Experience   |   |   | Independence Criteria (Note) |   |   |   |   |   |   |   | Number of Other Public Companies in Which the Individual is Concurrently Serving as an Remuneration Committee Member | Remarks |  |
|----------------------|-----------------|----------|--|---|---|------------------------------|---|---|---|---|---|---|---|--|---------|--|
|                      |                 |          | An instructor or higher position in a department of commerce, law, finance, accounting, or other academic department related to the business needs of the Company in a public or private junior college, college or university | A judge, public prosecutor, attorney, Certified Public Accountant, or other professional or technical specialist who has passed a national examination and been awarded a certificate in a profession necessary for the business of the Company | Has work experience in the areas of commerce, law, finance, or accounting, or otherwise necessary for the business of the Company | 1                            | 2 | 3 | 4 | 5 | 6 | 7 | 8 |  |         |  |
| Independent Director | Chen Kuo Hong   |          |  |   | √   | √                            | √ | √ | √ | √ | √ | √ | √ | √  | 1       |  |
| Independent director | Hsieh Han Chang |          |  |   | √   | √                            | √ | √ | √ | √ | √ | √ | √ | √  | 0       |  |
| Other                | Tseng Ming-ren  |          |  |   | √   | √                            | √ | √ | √ | √ | √ | √ | √ | √  | 1       |  |

Note:

1. Not an employee of the Company or any of its affiliates.
2. Directors and supervisors not affiliated with the company or its conglomerates (not limited to concurrent independent directors designated by the company, parent company, subsidiary, or subsidiary under the same parent company by the local regulations).
3. Not a natural-person shareholder who holds shares, together with those held by the person's spouse, minor children, or held by the person under others' names, in an aggregate amount of 1% or more of the total number of outstanding shares of the Company, or ranking in the top 10 in holdings.
4. Not managers listed in (1), or listed in (2) or (3) spouses, within second-degree relatives or within third-degree immediate relatives.
5. No direct holding of more than 5% of shares issued by the company, not ranking top five in shareholding, and not representatives appointed in Subparagraph 1 and 2 of Article 27 of the Company Act serving as corporate shareholder directors, supervisors, or employed persons, (not limited to concurrent independent directors designated by the company, parent company, subsidiary, or subsidiary under the same parent company by the local regulations).
6. Directors, supervisors, or employed persons of other companies not exceeding half of the company's director seats or shares with voting right controlled by the same person (not limited to concurrent independent directors designated by the company, parent company, subsidiary, or subsidiary under the same parent company by the local regulations).
7. Not the same person as the company's chairman, general manager (or equivalent position); not the spouse's company or institution board of directors (directors), supervisors (members of the board of supervisors), or employed persons (not limited to concurrent independent directors designed by the company, parent company, subsidiary, or subsidiary under the same parent company by the local regulations).

8. Board of directors (directors), supervisors (members of the board of supervisors), managers, or shareholders with more than 5% shareholding of specific companies or institutions without financial or business dealings with the company (not limited to specific companies or institutions with more than 20% but not exceeding 50% of shares issued by the company and concurrent independent directors designated by local regulations of the company and its parent company and subsidiary company or subsidiaries under the same parent company).
9. Professionals engaged in commercial, legal, financial, accounting, and other related services whose audits are not provided by the company or its conglomerates or whose cumulative rewards in the recent two years have not exceeded NT\$500,000, sole proprietors, company or institution owners, partners, directors (board of directors (directors), supervisors (members of the board of supervisors), managers, and their spouses. (not limited to the members of the Remuneration Committee, Public Takeover Review Committee, or Mergers and Acquisition Special Committee performing their duties in accordance with the Securities Exchanges Act or the Business Mergers And Acquisitions Act)
10. Not a person of any conditions defined in Article 30 of the Company Law.

## 2. Attendance of Members at Remuneration Committee Meetings

(1) There are 3 members in the Remuneration Committee.

(2) The term in office of the members (4<sup>th</sup> term): from June 8, 2018 to June 7, 2021. The Remuneration Committee convened 3 [A] meetings in 2020. The qualification of members and their attendance status are as follows:

| Title     | Name            | Actual number of attendance (B) | Attend through proxy | Percentage of actual attendance (%) [B/A] | Note  |
|-----------|-----------------|---------------------------------|----------------------|---|---|
| Convener  | Chen Kuo Hong   | 3                               | 0                    | 100 % (Required attendance: 5)            | Re-elected (date of election: June 8, 2018) |
| Committee | Hsieh Han Chang | 3                               | 0                    | 100 % (Required attendance: 5)            | New elect (date of election: June 8, 2018)  |
| Committee | Tseng Ming-ren  | 3                               | 0                    | 100 % (Required attendance: 5)            | New elect (date of election: June 8, 2018)  |

Other mentionable items:

1. The Board may not accept the recommendations of the Remuneration Committee, or revise the recommendations, specify the date of the Board meeting, the term, the content of the motion, the resolution of the Board, and the response of the Board towards the opinions of the Remuneration Committee (e.g., the remuneration package passed by the Board is superior to the recommendation of the Remuneration Committee, specify the difference and the reasons): None.
2. If any of the members of the Remuneration Committee hold adverse opinion or qualified opinions with record or in written declaration against the resolutions of the committee, specify the date and the session of the committee meeting, the content of the motion, the opinions of all members and the response to the opinions of the members: None.

| Remuneration Committee                          | Details of the relevant agendas and the subsequent  | Compensation Committee member's objection or reservation | The company's handling of the Compensation Committee's opinions           |
|---|---|--|---|
| 2020.1.18<br>4th Board of Directors 8rd Meeting | 1. Review the company's 2019 performance bonus (year-end bonus) case: The principle of distribution involves the adoption of the two-month salary of all the employees as the upper limit. The department supervisors shall submit distribution recommendation based on employees' annual contribution to the company, which based on performance assessment authority shall be submitted to the general manager for approval.  | None   | Board of Directors Meeting on 1/18<br>Approved by all attending directors |
|   | 2. Reviewed the company's 2020 manager performance bonus (year-end bonus) case: The distribution principle is based on the work performance of managers, annual contribution, and KPI achievement situation. In addition, based on the overall performance of departments, distribution recommendations are reported as shown in the attachment, which shall be resolved by the Remunerations Committee.                        | None   |   |
|   | 3. The motion of appointment of the new general manager:<br>The Senior General Manager of Manufacturing Center and the Vice General Manager of Marketing Center Hsu Chia-Hung is promoted to the post of General Manager of the double General Manager system   | None   |   |
|   | 4. Head of the Management Center:<br>The former head of the Management Center resigned amidst his career planning. That post is concurrently served by the Vice General Manager Li Mei-Hui of the Department of Finance.  | None   |   |
|   | The company's handling of the Compensation Committee member's opinion: not applicable<br>Resolution: All present member of the Remuneration Committee agreed and passed every proposal  |  |   |
| 2020.3.19<br>4th Board of Directors 9th Meeting | 1. The motion of a routine evaluation of the performance by directors, managerial officers and their remuneration in terms of policies, systems, standards/criteria and structure. The outcome of evaluation indicates that the current remunerations granted to the directors and managerial officers, their evaluation of performance and rules for their remuneration prove appropriate and shall be put into continued use. | None   | Board of Directors Meeting on 3/19<br>Approved by all attending directors |
|   | 2. Reviewed the Company's 2019 remunerations for employees and directors case: In accordance with the corporate charter, if profits are made, 3%~15% of profits should be allocated as remuneration for employees and not more than 3% allocated as remuneration for directors. The remunerations for employees totaled \$77,000,000, and the remunerations for the directors totaled \$3,500,000.                              | None   |   |
|   | The company's handling of the Compensation Committee member's opinion: not applicable<br>Resolution: All present member of the Remuneration Committee agreed and passed every proposal  |  |   |

| Remuneration Committee   | Details of the relevant agendas and the subsequent   | Compensation Committee member's objection or reservation | The company's handling of the Compensation Committee's opinions           |
|--|--|--|---|
| 2020.9.29<br>4 <sup>th</sup> Board of Directors 10 <sup>th</sup> Meeting | 1. Reviewed the company's 2019 remunerations distributed to directors' case: Passed the 2019 remuneration for directors in the amount of \$3,500,000 and amounts distributed to the directors at the shareholders' meeting on June 10, 2020.   | None   | Board of Directors Meeting on 9/29<br>Approved by all attending directors |
|  | 2. Reviewed the company's 2019 distribution of bonuses to managers case: According to the corporate charter, the manager's work performance and annual contribution, and the departments' overall performance, the bonus distribution is as shown in the attachment, which shall be resolved by the Remunerations Committee. | None   |   |
|  | 3. Reviewed the company's Compensation Committee 2021 calendar schedule case.  | None   |   |
|  | The company's handling of the Compensation Committee member's opinion: not applicable<br>Resolution: All present member of the Remuneration Committee agreed and passed every proposal   |  |   |

### 3.3.5 Corporate Social Responsibility

| Evaluation Item   | Implementation Status |    |  | Deviations from “the Corporate Social Responsibility Best-Practice Principles for TWSE/TPEX Listed Companies” and Reasons |
|---|-----------------------|----|--|---|
|   | Yes                   | No | Abstract Explanation   |   |
| 1. Does the company conducted a risk assessment on the company’s operational plan related environment and social and corporate governance issues, and has it formulated related risk management policies or strategies? | V                     |    | <p>Here at the Company, the Implementation Office under the jurisdiction of the Corporate Social Responsibility Committee” initiate the “CSR Report” Project. Through surveys of six major types of stakeholders, including customers, employees, suppliers, investors/mass media, government/academic units, communities/nonprofit organizations toward the key concerns about economic, social, environmental, and corporate governance, we duly conduct risk impact analysis based on their respective levels of impact, evaluate the potential risks that they fail to achieve, and formulate management policies and risk management policies and measures and continually ensure their effectiveness through tracking and evaluation procedures as annual progress goals of every year..</p> <p>The major issues of concern were identified and underwent risk management in 2020. The issues have been announced on the website.</p>  | None  |
| 2. Does the company establish exclusively (or concurrently) dedicated first-line managers authorized by the board to be in charge of proposing the corporate social responsibility policies and reporting to the board? | V                     |    | <p>Flytech has set up “Corporate Social Responsibility Code of Practice” based on “Corporate Governance Best Practice Principles for TWSE List Companies” and approved it on 2015 May board of director meeting. It has been disclosed on company official website: <a href="http://www.flytech.com">http://www.flytech.com</a> and M.O.P.S.</p> <p>In the Company, we have duly set up the “Corporate Social Responsibility Committee” where the Chairman serves as the convener and the General Manager serves as the Chief Committee Member. The committee thereunder oversees five branch sections, i.e. Sustainability Management Section/Corporate Commitment Section/Green Operation Section/Employee Care Section/Social Participation Section to arrange resources and plan management methods and to assume the respective responsibility for tracking each Section’s duties (for more details about the relevant job duties, please refer to the Company’s corporate website: About Flytech/Investor relations/Corporate Governance/Explanation of Corporate Sustainability and CSR) to</p> | None  |



| Evaluation Item  | Implementation Status |    |  | Deviations from “the Corporate Social Responsibility Best-Practice Principles for TWSE/TPEX Listed Companies” and Reasons |
|--|-----------------------|----|--|---|
|  | Yes                   | No | Abstract Explanation   |   |
|  |                       |    | <p>jointly fulfill corporate social responsibility and to reassess the implementation effectiveness. In each and every year, on a regular basis, we arrange publicity courses to publicize the CSR policy toward directors and employees. The performance of implementation and improvement plan would be reported to the board of directors meeting convened in the first quarter of the ensuing year.</p> <p>In 2020, the Corporate Social Responsibility (CSR) policy was faithfully implemented exactly as required while the Company did not undergo any significant abnormalities or risks. The outcome of implementation including key issues the communications with stakeholders were already reported to the board of directors meeting convened on March 18, 2021.</p>  |   |
| <p>3. Environmental Issues</p> <p>(1) Does the company establish proper environmental management systems based on the characteristics of their industries?</p> | V                     |    | <p>(1) The company’s Corporate Social Responsibility Guidelines have set principles for sustainable development by which the company should abide. These principles including obeying environmental legislation and related international guidelines, increasing resource utility efficiency, building a proper environmental management system, setting up dedicated departments/units/staff for environmental management that will draft, implement and maintain related environmental management systems and concrete action plans; organize environmental educational classes for management and employees; properly utilize water resources; and conduct company greenhouse gas emission audits to reduce the company’s environmental impact on the environment. With ethical and sustainability as principles, we will build a positive operational environment. We will focus on our expertise and develop excellent products to generate revenue and profit that we can share with customers, suppliers, shareholders, employees, and other stakeholders, all the while fulfilling our social responsibilities.</p> <p>The company obtained International Environmental Management System ISO14001 certification in 2011 (passed certificate renewal</p> | None.   |

| Evaluation Item  | Implementation Status |    |   | Deviations from “the Corporate Social Responsibility Best-Practice Principles for TWSE/TPEX Listed Companies” and Reasons |
|--|-----------------------|----|---|---|
|  | Yes                   | No | Abstract Explanation  |   |
| <p>(2) Does the company endeavor to utilize all resources more efficiently and use renewable materials which have low impact on the environment?</p> <p>(3) Does the company assessed the risks and opportunities arising from climate change on the present and future of the enterprise? Have coping measures for climate change related issues been adopted?</p> <p>(4) Does the company monitor the impact of climate change on its operations and conduct greenhouse gas inspections, as well as establish company strategies for energy conservation and carbon reduction?</p> |                       |    | <p>review in 2019: 2015 version (validity period from September 22, 2019 through September 21, 2022). In terms of product design, we adopt energy-conserving, environmentally friendly design, and primary materials that have minimal pollution and are environmentally friendly; in production processes, we adopt lead-free production procedures, and both our spare parts and finished products are RoHS certified; through waste management plans, obeying laws, improving resource recycling, and preventing and monitoring air/water pollution, we continue to reduce carbon emissions and build a sustainable environment while reducing our impact on the environment, and keeping pace with international trends and client expectations.</p> <p>(2) the same as the description in (1).</p> <p>(3) The Company evaluates its business model and determines that the most relevant issues related to climate change include such factors: Greenhouse gas emissions, rise in average temperature, increase in the number of extreme weather days, the definite difference between dry and wet seasons and the like. After assessing the degrees of impact and risks, we duly enumerate the risks and opportunities along with the correspondent countermeasures through the Company’s corporate website: Investor Relationship/Corporate Governance/Risk Management page.</p> <p>(4) The company began checking greenhouse emissions beginning 2015. The management strategies, methods, goals, and emission reduction goal have been set up, and improvement continues to be monitored. For management policies pertaining to energy conservation, carbon reduction, greenhouse gas reduction, water usage deduction, or other waste, refer to descriptions on page 109~110, including monitoring data of greenhouse gas, waste, and electricity and indirect reduction of water and energy discharge, as follows. Improvement continued to be made in 2020. The checking reports for two years have been disclosed on the Market Observation Post System.</p> |   |

| Evaluation Item   | Implementation Status |   |   | Deviations from “the Corporate Social Responsibility Best-Practice Principles for TWSE/TPEX Listed Companies” and Reasons |      |                         |       |           |                   |      |             |     |           |      |             |     |           |              |      |               |     |           |      |               |     |           |          |      |                           |                                |                                     |                   |      |       |        |        |      |       |        |        |              |      |        |        |       |      |        |        |       |          |      |   |                                |                                     |                   |                    |             |        |        |              |            |      |                    |             |        |        |             |            |      |              |                    |               |         |        |              |            |      |                    |               |        |       |             |            |      |  |
|-------------------|-----------------------|---|---|---|------|-------------------------|-------|-----------|-------------------|------|-------------|-----|-----------|------|-------------|-----|-----------|--------------|------|---------------|-----|-----------|------|---------------|-----|-----------|----------|------|---------------------------|--------------------------------|-------------------------------------|-------------------|------|-------|--------|--------|------|-------|--------|--------|--------------|------|--------|--------|-------|------|--------|--------|-------|----------|------|---|--------------------------------|-------------------------------------|-------------------|--------------------|-------------|--------|--------|--------------|------------|------|--------------------|-------------|--------|--------|-------------|------------|------|--------------|--------------------|---------------|---------|--------|--------------|------------|------|--------------------|---------------|--------|-------|-------------|------------|------|--|
|                   | Yes                   | No                                      | Abstract Explanation  |   |      |                         |       |           |                   |      |             |     |           |      |             |     |           |              |      |               |     |           |      |               |     |           |          |      |                           |                                |                                     |                   |      |       |        |        |      |       |        |        |              |      |        |        |       |      |        |        |       |          |      |   |                                |                                     |                   |                    |             |        |        |              |            |      |                    |             |        |        |             |            |      |              |                    |               |         |        |              |            |      |                    |               |        |       |             |            |      |  |
|                   |                       |   | <p>(A) The annual discharge volume of greenhouse emissions is related to the area of the office floor and the number of users.</p> <table border="1"> <thead> <tr> <th>Location</th> <th>Year</th> <th>Electricity consumption</th> <th>Labor</th> <th>Per labor</th> </tr> </thead> <tbody> <tr> <td rowspan="2">Neihu Headquarter</td> <td>2019</td> <td>833,623 kWh</td> <td>188</td> <td>4,434 kWh</td> </tr> <tr> <td>2020</td> <td>842,237 kWh</td> <td>192</td> <td>4,387 kWh</td> </tr> <tr> <td rowspan="2">Linkou Plant</td> <td>2019</td> <td>2,174,679 kWh</td> <td>265</td> <td>8,206 kWh</td> </tr> <tr> <td>2020</td> <td>2,089,214 kWh</td> <td>255</td> <td>8,192 kWh</td> </tr> </tbody> </table> <p>(B) Direct Discharge of Waste</p> <table border="1"> <thead> <tr> <th>Location</th> <th>Year</th> <th>Total disposal volume (t)</th> <th>Total CO2 Discharge volume (t)</th> <th>Ratio in total discharge volume (%)</th> </tr> </thead> <tbody> <tr> <td rowspan="2">Neihu Headquarter</td> <td>2019</td> <td>6.7 t</td> <td>13.8 t</td> <td>23.7 %</td> </tr> <tr> <td>2020</td> <td>6.3 t</td> <td>13.0 t</td> <td>22.4 %</td> </tr> <tr> <td rowspan="2">Linkou Plant</td> <td>2019</td> <td>29.8 t</td> <td>61.3 t</td> <td>5.1 %</td> </tr> <tr> <td>2020</td> <td>29.2 t</td> <td>60.2 t</td> <td>5.4 %</td> </tr> </tbody> </table> <p>(C) Indirect discharge of energy from electricity and water consumption</p> <table border="1"> <thead> <tr> <th>Location</th> <th>Year</th> <th>Total electricity and water consumption</th> <th>Total CO2 Discharge volume (t)</th> <th>Ratio in total discharge volume (%)</th> </tr> </thead> <tbody> <tr> <td rowspan="4">Neihu Headquarter</td> <td>2019 (Electricity)</td> <td>833,623 kWh</td> <td>43.9 t</td> <td rowspan="2">76.3 %</td> </tr> <tr> <td>2019 (water)</td> <td>3,209 unit</td> <td>0.5t</td> </tr> <tr> <td>2020 (Electricity)</td> <td>842,237 kWh</td> <td>44.3 t</td> <td rowspan="2">77.5 %</td> </tr> <tr> <td>2020(water)</td> <td>4,136 unit</td> <td>0.6t</td> </tr> <tr> <td rowspan="4">Linkou Plant</td> <td>2019 (Electricity)</td> <td>2,174,679 kWh</td> <td>1,158 t</td> <td rowspan="2">94.9 %</td> </tr> <tr> <td>2019 (water)</td> <td>7,450 unit</td> <td>1.1t</td> </tr> <tr> <td>2020 (Electricity)</td> <td>2,089,214 kWh</td> <td>1,063t</td> <td rowspan="2">94.6%</td> </tr> <tr> <td>2020(water)</td> <td>7,450 unit</td> <td>1.1t</td> </tr> </tbody> </table> | Location  | Year | Electricity consumption | Labor | Per labor | Neihu Headquarter | 2019 | 833,623 kWh | 188 | 4,434 kWh | 2020 | 842,237 kWh | 192 | 4,387 kWh | Linkou Plant | 2019 | 2,174,679 kWh | 265 | 8,206 kWh | 2020 | 2,089,214 kWh | 255 | 8,192 kWh | Location | Year | Total disposal volume (t) | Total CO2 Discharge volume (t) | Ratio in total discharge volume (%) | Neihu Headquarter | 2019 | 6.7 t | 13.8 t | 23.7 % | 2020 | 6.3 t | 13.0 t | 22.4 % | Linkou Plant | 2019 | 29.8 t | 61.3 t | 5.1 % | 2020 | 29.2 t | 60.2 t | 5.4 % | Location | Year | Total electricity and water consumption | Total CO2 Discharge volume (t) | Ratio in total discharge volume (%) | Neihu Headquarter | 2019 (Electricity) | 833,623 kWh | 43.9 t | 76.3 % | 2019 (water) | 3,209 unit | 0.5t | 2020 (Electricity) | 842,237 kWh | 44.3 t | 77.5 % | 2020(water) | 4,136 unit | 0.6t | Linkou Plant | 2019 (Electricity) | 2,174,679 kWh | 1,158 t | 94.9 % | 2019 (water) | 7,450 unit | 1.1t | 2020 (Electricity) | 2,089,214 kWh | 1,063t | 94.6% | 2020(water) | 7,450 unit | 1.1t |  |
| Location          | Year                  | Electricity consumption                 | Labor   | Per labor   |      |                         |       |           |                   |      |             |     |           |      |             |     |           |              |      |               |     |           |      |               |     |           |          |      |                           |                                |                                     |                   |      |       |        |        |      |       |        |        |              |      |        |        |       |      |        |        |       |          |      |   |                                |                                     |                   |                    |             |        |        |              |            |      |                    |             |        |        |             |            |      |              |                    |               |         |        |              |            |      |                    |               |        |       |             |            |      |  |
| Neihu Headquarter | 2019                  | 833,623 kWh                             | 188   | 4,434 kWh   |      |                         |       |           |                   |      |             |     |           |      |             |     |           |              |      |               |     |           |      |               |     |           |          |      |                           |                                |                                     |                   |      |       |        |        |      |       |        |        |              |      |        |        |       |      |        |        |       |          |      |   |                                |                                     |                   |                    |             |        |        |              |            |      |                    |             |        |        |             |            |      |              |                    |               |         |        |              |            |      |                    |               |        |       |             |            |      |  |
|                   | 2020                  | 842,237 kWh                             | 192   | 4,387 kWh   |      |                         |       |           |                   |      |             |     |           |      |             |     |           |              |      |               |     |           |      |               |     |           |          |      |                           |                                |                                     |                   |      |       |        |        |      |       |        |        |              |      |        |        |       |      |        |        |       |          |      |   |                                |                                     |                   |                    |             |        |        |              |            |      |                    |             |        |        |             |            |      |              |                    |               |         |        |              |            |      |                    |               |        |       |             |            |      |  |
| Linkou Plant      | 2019                  | 2,174,679 kWh                           | 265   | 8,206 kWh   |      |                         |       |           |                   |      |             |     |           |      |             |     |           |              |      |               |     |           |      |               |     |           |          |      |                           |                                |                                     |                   |      |       |        |        |      |       |        |        |              |      |        |        |       |      |        |        |       |          |      |   |                                |                                     |                   |                    |             |        |        |              |            |      |                    |             |        |        |             |            |      |              |                    |               |         |        |              |            |      |                    |               |        |       |             |            |      |  |
|                   | 2020                  | 2,089,214 kWh                           | 255   | 8,192 kWh   |      |                         |       |           |                   |      |             |     |           |      |             |     |           |              |      |               |     |           |      |               |     |           |          |      |                           |                                |                                     |                   |      |       |        |        |      |       |        |        |              |      |        |        |       |      |        |        |       |          |      |   |                                |                                     |                   |                    |             |        |        |              |            |      |                    |             |        |        |             |            |      |              |                    |               |         |        |              |            |      |                    |               |        |       |             |            |      |  |
| Location          | Year                  | Total disposal volume (t)               | Total CO2 Discharge volume (t)  | Ratio in total discharge volume (%)   |      |                         |       |           |                   |      |             |     |           |      |             |     |           |              |      |               |     |           |      |               |     |           |          |      |                           |                                |                                     |                   |      |       |        |        |      |       |        |        |              |      |        |        |       |      |        |        |       |          |      |   |                                |                                     |                   |                    |             |        |        |              |            |      |                    |             |        |        |             |            |      |              |                    |               |         |        |              |            |      |                    |               |        |       |             |            |      |  |
| Neihu Headquarter | 2019                  | 6.7 t                                   | 13.8 t  | 23.7 %  |      |                         |       |           |                   |      |             |     |           |      |             |     |           |              |      |               |     |           |      |               |     |           |          |      |                           |                                |                                     |                   |      |       |        |        |      |       |        |        |              |      |        |        |       |      |        |        |       |          |      |   |                                |                                     |                   |                    |             |        |        |              |            |      |                    |             |        |        |             |            |      |              |                    |               |         |        |              |            |      |                    |               |        |       |             |            |      |  |
|                   | 2020                  | 6.3 t                                   | 13.0 t  | 22.4 %  |      |                         |       |           |                   |      |             |     |           |      |             |     |           |              |      |               |     |           |      |               |     |           |          |      |                           |                                |                                     |                   |      |       |        |        |      |       |        |        |              |      |        |        |       |      |        |        |       |          |      |   |                                |                                     |                   |                    |             |        |        |              |            |      |                    |             |        |        |             |            |      |              |                    |               |         |        |              |            |      |                    |               |        |       |             |            |      |  |
| Linkou Plant      | 2019                  | 29.8 t                                  | 61.3 t  | 5.1 %   |      |                         |       |           |                   |      |             |     |           |      |             |     |           |              |      |               |     |           |      |               |     |           |          |      |                           |                                |                                     |                   |      |       |        |        |      |       |        |        |              |      |        |        |       |      |        |        |       |          |      |   |                                |                                     |                   |                    |             |        |        |              |            |      |                    |             |        |        |             |            |      |              |                    |               |         |        |              |            |      |                    |               |        |       |             |            |      |  |
|                   | 2020                  | 29.2 t                                  | 60.2 t  | 5.4 %   |      |                         |       |           |                   |      |             |     |           |      |             |     |           |              |      |               |     |           |      |               |     |           |          |      |                           |                                |                                     |                   |      |       |        |        |      |       |        |        |              |      |        |        |       |      |        |        |       |          |      |   |                                |                                     |                   |                    |             |        |        |              |            |      |                    |             |        |        |             |            |      |              |                    |               |         |        |              |            |      |                    |               |        |       |             |            |      |  |
| Location          | Year                  | Total electricity and water consumption | Total CO2 Discharge volume (t)  | Ratio in total discharge volume (%)   |      |                         |       |           |                   |      |             |     |           |      |             |     |           |              |      |               |     |           |      |               |     |           |          |      |                           |                                |                                     |                   |      |       |        |        |      |       |        |        |              |      |        |        |       |      |        |        |       |          |      |   |                                |                                     |                   |                    |             |        |        |              |            |      |                    |             |        |        |             |            |      |              |                    |               |         |        |              |            |      |                    |               |        |       |             |            |      |  |
| Neihu Headquarter | 2019 (Electricity)    | 833,623 kWh                             | 43.9 t  | 76.3 %  |      |                         |       |           |                   |      |             |     |           |      |             |     |           |              |      |               |     |           |      |               |     |           |          |      |                           |                                |                                     |                   |      |       |        |        |      |       |        |        |              |      |        |        |       |      |        |        |       |          |      |   |                                |                                     |                   |                    |             |        |        |              |            |      |                    |             |        |        |             |            |      |              |                    |               |         |        |              |            |      |                    |               |        |       |             |            |      |  |
|                   | 2019 (water)          | 3,209 unit                              | 0.5t  |   |      |                         |       |           |                   |      |             |     |           |      |             |     |           |              |      |               |     |           |      |               |     |           |          |      |                           |                                |                                     |                   |      |       |        |        |      |       |        |        |              |      |        |        |       |      |        |        |       |          |      |   |                                |                                     |                   |                    |             |        |        |              |            |      |                    |             |        |        |             |            |      |              |                    |               |         |        |              |            |      |                    |               |        |       |             |            |      |  |
|                   | 2020 (Electricity)    | 842,237 kWh                             | 44.3 t  | 77.5 %  |      |                         |       |           |                   |      |             |     |           |      |             |     |           |              |      |               |     |           |      |               |     |           |          |      |                           |                                |                                     |                   |      |       |        |        |      |       |        |        |              |      |        |        |       |      |        |        |       |          |      |   |                                |                                     |                   |                    |             |        |        |              |            |      |                    |             |        |        |             |            |      |              |                    |               |         |        |              |            |      |                    |               |        |       |             |            |      |  |
|                   | 2020(water)           | 4,136 unit                              | 0.6t  |   |      |                         |       |           |                   |      |             |     |           |      |             |     |           |              |      |               |     |           |      |               |     |           |          |      |                           |                                |                                     |                   |      |       |        |        |      |       |        |        |              |      |        |        |       |      |        |        |       |          |      |   |                                |                                     |                   |                    |             |        |        |              |            |      |                    |             |        |        |             |            |      |              |                    |               |         |        |              |            |      |                    |               |        |       |             |            |      |  |
| Linkou Plant      | 2019 (Electricity)    | 2,174,679 kWh                           | 1,158 t   | 94.9 %  |      |                         |       |           |                   |      |             |     |           |      |             |     |           |              |      |               |     |           |      |               |     |           |          |      |                           |                                |                                     |                   |      |       |        |        |      |       |        |        |              |      |        |        |       |      |        |        |       |          |      |   |                                |                                     |                   |                    |             |        |        |              |            |      |                    |             |        |        |             |            |      |              |                    |               |         |        |              |            |      |                    |               |        |       |             |            |      |  |
|                   | 2019 (water)          | 7,450 unit                              | 1.1t  |   |      |                         |       |           |                   |      |             |     |           |      |             |     |           |              |      |               |     |           |      |               |     |           |          |      |                           |                                |                                     |                   |      |       |        |        |      |       |        |        |              |      |        |        |       |      |        |        |       |          |      |   |                                |                                     |                   |                    |             |        |        |              |            |      |                    |             |        |        |             |            |      |              |                    |               |         |        |              |            |      |                    |               |        |       |             |            |      |  |
|                   | 2020 (Electricity)    | 2,089,214 kWh                           | 1,063t  | 94.6%   |      |                         |       |           |                   |      |             |     |           |      |             |     |           |              |      |               |     |           |      |               |     |           |          |      |                           |                                |                                     |                   |      |       |        |        |      |       |        |        |              |      |        |        |       |      |        |        |       |          |      |   |                                |                                     |                   |                    |             |        |        |              |            |      |                    |             |        |        |             |            |      |              |                    |               |         |        |              |            |      |                    |               |        |       |             |            |      |  |
|                   | 2020(water)           | 7,450 unit                              | 1.1t  |   |      |                         |       |           |                   |      |             |     |           |      |             |     |           |              |      |               |     |           |      |               |     |           |          |      |                           |                                |                                     |                   |      |       |        |        |      |       |        |        |              |      |        |        |       |      |        |        |       |          |      |   |                                |                                     |                   |                    |             |        |        |              |            |      |                    |             |        |        |             |            |      |              |                    |               |         |        |              |            |      |                    |               |        |       |             |            |      |  |

| Evaluation Item   | Implementation Status |    |  | Deviations from “the Corporate Social Responsibility Best-Practice Principles for TWSE/TPEX Listed Companies” and Reasons |
|---|-----------------------|----|--|---|
|   | Yes                   | No | Abstract Explanation   |   |
|   |                       |    | <p>In accordance with the latest announcement of the Bureau of Energy, Ministry of Economic Affairs, the 2019 water discharge coefficient is calculated by 0.150kg CO2/degree.</p> <p>In accordance with the latest announcement of the Bureau of Energy, Ministry of Economic Affairs, the 2019 electricity discharge coefficient is calculated by 0.509kg CO2/degree.</p> <p>(1)~(4) above were implemented in 2020 as provisioned.</p>  |   |
| <p>4. Social Issues</p> <p>(1) Does the company formulate appropriate management policies and procedures according to relevant regulations and the International Bill of Human Rights?</p> <p>(2) Does the company set up and implemented reasonable employee welfare measures (including salaries, holidays, and other benefits), and have business performance or results been appropriately reflected in employee remunerations?</p> | V                     |    | <p>(1) In consideration to the fulfillment of corporate social responsibility and human rights protection and in reference to the Universal Declaration of Human Rights, Un Global Compact, ILO Declaration on Fundamental Principles and Rights at Work, and other internationally recognized human rights standards, the company has set up the “human rights policy,” which was announced in January for implementation in order to prevent conduct infringing upon and violating human rights. In addition to providing a reasonable and safe environment and ensuring current employees are given reasonable and dignified treatment.</p> <p>(2) The company has set up the ‘Leave Category Management Guidelines’ to regulate the leave-taking and holiday management system. In 1992, the Employee Welfare Committee was set up to provide various employee welfare activities and subsidies. In terms of remunerations, the provisions in the “Corporate Charter” shall apply. If the company has made profits for the year, 3%~15% shall be designated as employee remunerations. In addition, the company has set up the “Salary and Bonus Management Guidelines,” “Performance Management Guidelines,” and “Award and Punishment Management Guidelines” to provision remuneration policies such as fixed salaries, bonuses, and employee remunerations, etc. The Remunerations Committee shall periodically conduct reviews, which are supplemented by performance operation assessments including: employee performance, internal control system compliance situation, and compliance to various company policies including the social</p> | None.   |

| Evaluation Item  | Implementation Status |    |  | Deviations from “the Corporate Social Responsibility Best-Practice Principles for TWSE/TPEX Listed Companies” and Reasons |
|--|-----------------------|----|--|---|
|  | Yes                   | No | Abstract Explanation   |   |
| (3) Does the company provide a healthy and safe working environment and organize training on health and safety for its employees on a regular basis? |                       |    | <p>responsibility system. Awards or punishments are granted accordingly based on the remuneration policies and Award and Punishment Management Guidelines. The remuneration policies are briefed below:</p> <p>(A) Fixed salary (this salary, professional addition, job addition): According to the labor law and the employee's academic experience and work ability, it is not determined by age, gender and ethnicity.</p> <p>(B) Year-end bonus and performance bonus: The year-end bonus is based on the annual operating status. According to the performance of each employee's performance appraisal and KPI, the bonus amount is determined. The performance bonus is based on the business/production/R&amp;D/project performance of each department and the contribution of each employee. And approved.</p> <p>(C) Employee compensation: Calculate the approved individual allocation amount based on the results of each employee's performance appraisal and KPI achievement.</p> <p>(D) Salary policy: The annual salary adjustment is based on the previous year's business performance and market salary status. Individual promotion and salary adjustment will be handled in accordance with the “Management Measures for Awards and Punishments.”</p> <p>(3) The Company successfully obtained the ISO 14001 environmental management system certification in 2001 and obtained the ISO 45001 occupational safety and health standard management structure in 2020. That means the Company has integrated and established a complete and very sound safety and health working environment.</p> <p>The Company has duly established a “Labor Safety and Health Committee” in accordance with the Occupational Safety and Health Act and laws and ordinances concerned (which was consolidated and upgraded into the “Environmental Safety and</p> |   |

| Evaluation Item | Implementation Status |    |   | Deviations from “the Corporate Social Responsibility Best-Practice Principles for TWSE/TPEX Listed Companies” and Reasons |
|-----------------|-----------------------|----|---|---|
|                 | Yes                   | No | Abstract Explanation  |   |
|                 |                       |    | <p>Health Committee” after the Company obtained the ISO 45001 system certification in 2020). The members of such Committee include the supervisors and staff members working with the Neihu Headquarters and the Linkou Plant. Other than such duties to draft methods of operation, the Committee assumes the responsibilities for occupational safety training at the Neihu Headquarters and the Linkou plant in such professional duties including reviewing the training programs for safety of machinery, equipment and raw materials, reviewing occupational calamity investigation reports, assessing on-the-spot occupational safety performance and the like to carry out all aspects of security. Further, on a regular basis, the Committee sponsors and carries out educational &amp; training programs focusing on safety and health, fire protection and other related contents, and takes necessary preventive measures against potential occupational disaster to minimize the potential risk factors of the working environment. Through all such efforts in combination, the Committee establishes and ensures a safe and healthy workplace. The hands-on implementation status is as enumerated below:</p> <p>(A) Take labor insurance, health insurance, and group insurance for the protection of the employees.</p> <p>(B) Ensure safe workplace environments and provide qualified operating equipment in accordance with the Labor Facilities Safety Regulations.</p> <p>(C) Have regular quarterly inspections and maintenances of fire-fighting facilities (fire extinguishers, fire prevention refuge facilities, emergency lights, electrical appliances, fire pumps and fire hydrants), annual inspections and maintenances of smoke ventilation equipment, employee safety educational training sessions and disaster prevention drills every 6 months.</p> <p>(D) Conduct daily / weekly / month / quarterly maintenance for various types of manufacturing equipment according to the ISO’s “Equipment Maintenance Procedures.”</p> |   |

| Evaluation Item  | Implementation Status |    |   | Deviations from “the Corporate Social Responsibility Best-Practice Principles for TWSE/TPEX Listed Companies” and Reasons |
|--|-----------------------|----|---|---|
|  | Yes                   | No | Abstract Explanation  |   |
| (4) Does the company setup a communication channel with employees on a regular basis, as well as reasonably inform employees of any significant changes in operations that may have an impact on them? |                       |    | <p>(E) Appoint professional technicians to inspect electrical equipment monthly.</p> <p>(F) Daily patrols by the Company’s security personnel.</p> <p>(G) Routine health examination for the employees every year.</p> <p>(H) Maintenances, replacement of filters, and water quality inspections for the company drinking-water equipment every 3 months.</p> <p>(I) Providing nutritious and healthy group lunch services for employees of the Linkou factory.</p> <p>(4) Exactly in accordance with ISO education and training methods and internal control procedures, the Company has duly mapped out employee training programs. The training methods are included in outsourced training programs and in-house courses.</p> <p>In terms of outsourced training programs, each and every department is required to submit its respective training programs and budgets to be approved at the end of each fiscal year and the employees shall submit their training applications based on the annual programs and their substantial needs. After the training programs are satisfactorily completed, they are required to submit their training experience report or opinion questionnaire to the Human Resources Training Department to register credits and share the course information or share training internally.</p> <p>The in-house training programs include: 1. Newcomer training. New recruits enter the basic course training on the day upon their registry in employment to ensure that they can quickly understand the team concept and culture at the very beginning when they join Flytech; 2. Project training. Such training programs are exclusive courses specifically intended to reserve cadres and middle- and high-level elite cadres, allowing the talent trainees from all levels to inherit the wisdom and practical operation of Flytech members</p> |   |

| Evaluation Item   | Implementation Status |    |  | Deviations from “the Corporate Social Responsibility Best-Practice Principles for TWSE/TPEX Listed Companies” and Reasons |
|---|-----------------------|----|--|---|
|   | Yes                   | No | Abstract Explanation   |   |
| <p>(5) Does the company complied with relevant regulations and international standards with regard to the health and safety of customers purchasing products or services, customer privacy, marketing, and labeling? Have relevant consumer rights protection policies and appeal procedures been set up?</p> <p>(6) Does the company set up supplier management policies and requested suppliers comply with relevant regulations on environmental protection, vocational safety and health, the human rights of laborers, and other issues? What is the implementation situation?</p> |                       |    | <p>to cultivate more elites and leaders in the future; 3. Credit system learning programs. Flytech sets the basic training credit requirements that all colleagues must achieve within the year and colleagues are participating to accumulate credits from various in-house and outsourced programs to leave a firm record for their own learning process to continually improve professional skills and self-growth; 4. Monthly Seminars [Flytech knowledge +] lectures. We invite external experts to share their hands-on profession. With the comprehensive training programs mentioned above, we have trained employees to improve their professional skills and career planning ability.</p> <p>(5) The company has provisioned in the “Code for Corporate Social Responsibility” compliance with relevant regulations and international standards regarding the marketing and labeling of its products and services. There must be no deceitful, misleading, or fraudulent conduct that breaks consumers’ trust or deprives consumers of their rights. In 2019, in compliance with GDPR, Taiwan’s Personal Information Protection Act, and other regulations, a personal information management system was established to protect customers’ privacy.</p> <p>(6) Within the Company’s “Corporate Social Responsibility Code,” we have duly regulated that whenever the Company signs a contract with a major supplier, the contents of such contract should include compliance with the corporate social responsibility policies of both parties and whenever a supplier violates the policy, it will cause a significant impact on the environment and society of the supply source community. The contract shall, as well, contain such terms that in case of violation, the contract can be either terminated or rescinded forthwith. In the substantial implementation, we faithfully comply with the Company’s ISO 9001 “Supplier Qualification Procedure” and “Supplier Evaluation and Performance Tracking Procedure” to select and firmly manage suppliers and counsel the suppliers to team up with the Company in close cooperative ties to implement corporate social</p> |   |



| Evaluation Item  | Implementation Status |    |   | Deviations from “the Corporate Social Responsibility Best-Practice Principles for TWSE/TPEX Listed Companies” and Reasons |
|--|-----------------------|----|---|---|
|  | Yes                   | No | Abstract Explanation  |   |
|  |                       |    | responsibilities, abide by business ethics, government environmental regulations, occupational safety and health regulations, labor regulations, and non-employment of child labor and other labor related human rights regulations.<br>(1)~(6) were implemented as provisioned in 2020.      |   |
| 5. Has the company compiled corporate social responsibility reports and other reports disclosing the company’s non-financial information in reference to internationally accepted report preparation standards or guides? Has the abovementioned report acquired validation or guarantee opinions from a third-party verification unit?  |                       | V  | The Company’s “Corporate Social Responsibility Committee” was successfully compiled in February 2021. Exactly in accordance with GRI standards, we have completed compilation of the 2019 Corporate Social Responsibility Report. The 2020 CSR Report is scheduled to be issued in June 2021. |   |
| 6. If the Company has established the corporate social responsibility principles based on “the Corporate Social Responsibility Best-Practice Principles for TWSE/TPEX Listed Companies”, please describe any discrepancy between the Principles and their implementation: None.  |                       |    |   |   |
| 7. Other important information to facilitate better understanding of the company’s corporate social responsibility practices :   |                       |    |   |   |
| <p>(1) Advocate full participation in social services, through community service and participation in various public welfare activities, to give back to society and fulfill the obligations of business operations. The 2020 annual preparation activities are as follows:</p> <p>(A) Cooperate with the "Blessing Committee" to set up "Flytech Loves Public Welfare Club " to organize and care for the weak activities and give gifts every two months.</p> <p>(B) As always, on an annual basis, we team up with universities/colleges to sponsor the “Starry Training Camp” during the summer and winter vacations. Through such an elaborately designed Camp, we provide a seven-day training program for university/college and graduate school students. Through the experience sharing with the Company’s senior executives and close practical interactions, the student trainees will be instructed with the updates of industry trends and will have a more direct understanding of the application field of industrial computers, the business model and products of the industrial computer industry. In turn, we promote cross-field and cross-professional student exchange programs. The training camp is held in each winter and summer vacation and each Camp is attended by more than thirty trainees from northern, central and southern areas of Taiwan to gather together in the significant learning process. Student trainees from different fields, expertise and backgrounds learn together in the well-designed training courses and grow together. Through the intensive training activities, in addition to allowing outstanding domestic students regarding the practical operation of the industry, the Camp further enables the trainees to learn practical hands-on experiences from each other amidst the exchange. Further, on a regular basis, we hold “Starry Alumni Association” lectures and gatherings to continually track the shared experiences and learned achievements among the Starry Alumni. So far, many student trainees have joined Flytech Group as regular employees after graduation from the Camp and become outstanding cadres with exceptional performance.</p> <p>(C) In coordination with the “Flytech Foundation” we organize activities to cultivate underprivileged students and promote technological innovation, including notably: (1) Scholarship trip “Corporate Heart Tours”: We generously offer scholarships to students from Taitung County High School (Vocational) schools for the outstanding students from poverty-stricken families. After the name list of the target students is confirmed, we sponsor award-winning programs to the</p> |                       |    |   |   |

| Evaluation Item | Implementation Status |    |                      | Deviations from “the Corporate Social Responsibility Best-Practice Principles for TWSE/TPEX Listed Companies” and Reasons |
|-----------------|-----------------------|----|----------------------|---|
|                 | Yes                   | No | Abstract Explanation |   |

worthy students who participate in the “Corporate Heart Tour” activities and award programs to broaden their horizons through the well-organized corporate visits. (2) The Design For Taiwan “DFT Workshop”: This is a plan for university/college students across Taiwan, from summer to winter vacations over a period of one year, with eight workshops to be sponsored (including three online workshops). Those students from colleges and universities will be organized into the respective teams to work out how to improve performance and efficiency on environmental/society/energy/education/discipline issues. After the fourth workshop was completed, we will sponsor the outstanding results display exhibition at Warehouse No. 2 of Taipei Sungshan Tobacco Mill in September 2020.

(D) Sponsored social service units or academic events.

(E) Held a company-wide energy conservation and carbon-reduction performance competition, held mountain-cleaning event in conjunction with the company’s annual factory celebration to realize the company’s environmental protection policy.

(F) Collect receipts monthly and donate to the Genesis Social Welfare Foundation, and donate books and magazines and recycled items to the Tzu Chi Foundation.

(2) The details of the events, the number of participants and the beneficiaries, industry-academia collaborations are as listed:

Unit: No. of Person

| Event Name                                     | Month of Event | Contents of Event   | Amount of Participating Employees | Beneficiaries / Number of Participants |
|--|----------------|---|-----------------------------------|--|
| Star Training Camp                             | 1,8            | Star Winter and Summer Training Camp, both sessions each had eight days of activities   | 60                                | 71                                     |
|  | 6,12           | Fanxin Alumni Association-two sessions (meals and social activities each for one day).  | 18                                | 96                                     |
| “Flytech Loves Public Welfare” Club Activities | 1              | Co-organized the "Send Warmth to Old Homes" with the Huashan Social Welfare Foundation to and provide resources.                            | 40                                | 25                                     |
|  | 8              | Second-hand goods online tendering into charity   | 150                               | 7,595 元                                |
|  | 7              | Second-hand goods auction tendering into charity  | 150                               | 2,900 元                                |
|  | 9              | Bali Animal Protection Association organized “Wave Me to Safeguard You” campaign  | 30                                |  |
|  | 11             | Guanyin Mountain “Climbing the mountains and crossing the ridges to purify mountains. We have you joining us all” clean mountain activities | 65                                | Clean up 61kg                          |

| Evaluation Item | Implementation Status |    |                      | Deviations from “the Corporate Social Responsibility Best-Practice Principles for TWSE/TPEX Listed Companies” and Reasons |
|-----------------|-----------------------|----|----------------------|---|
|                 | Yes                   | No | Abstract Explanation |   |

| Event Name   | Month of Event     | Contents of Event   | Amount of Participating Employees | Beneficiaries / Number of Participants |
|--|--------------------|---|-----------------------------------|--|
| Co-organized events with Flytech Foundation.         | 7                  | The "Travel Around Taiwan" event, a scholarship for the impoverished or outstanding students of Taitung County's Senior High Schools (including Vocational), had 1 sessions of activities and awards for three days each, leading students to visit enterprises to expand their horizons. | 20                                | 60                                     |
| Co-organized events with Flytech Foundation.         | 3,4,5,7,8,10,11,12 | Seven "DFT Workshop" (Online programs only during March, April, May)  | 36                                | 560                                    |
|  | 9                  | “DFT Workshop” Result Presentation  | 30                                | 6,694                                  |
| Sponsored Events                                     | 4                  | Sponsored Association of Police Friends in the amount of \$300,000.   |                                   |  |
| Energy-conservation and Carbon-reduction Competition | Monthly            | Electricity usage Evaluations and Awards Competition  | All Employees                     |  |

8.If the Company's products or Corporate Social Responsibility (CSR) report have passed the verification criteria of the relevant verification agree upon, they should be stated expressly:

Passed the certification review (validity period from December 3, 2020 through August 21, 2023).

ISO 13485 Medical Equipment Quality System: The 2016 version passed the certificate renewal review (validity period from January 29, 2019 through January 27, 2022).

ISO 14001 Environmental Management System: The 2015 version passed the certificate renewal review (validity period from September 22, 2019 through September 21, 2022).

ISO 45001 Occupational Safety and Health Management System: 2018 versoin (first time certification, valid from December 1, 2020 to November 30, 2023).

### 3.3.6 Ethical Corporate Management

| Evaluation Item   | Implementation Status |    |   | Deviations from “the Ethical Corporate Management Best-Practice Principles for TWSE/TPEX Listed Companies” and Reasons |
|---|-----------------------|----|---|--|
|   | Yes                   | No | Abstract Explanation  |  |
| <p>1. Establishment of ethical corporate management policies and programs</p> <p>(1) Has the company set up integrity operation policies passed by the board and explicitly stipulated integrity operation policies and practices in the regulations and external documents, as well as the board and senior management level’s commitment to active operational policy implementation?</p> <p>(2) Has the company established a dishonest conduct risk assessment mechanism to periodically analyze and assess business activities with higher dishonest conduct risk within the business cope, based on which plans for preventing dishonest conducts have been set up, at least covering the preventive measures of the conducts in Paragraph 2, Article 7 of the “Code for Integrity Operations of TAIEX and OTC Listed Companies”?</p> | V                     |    | <p>(1) The company has established Ethical Management Principles based on the Company Ethical Behavior Principles for Exchange-Listed and OTC-Listed Companies, submitted it, and had it approved to take effect by the board in May 2015. The Principles determine that the company and related enterprises/organizations should clearly demonstrate their ethical management policies in both their regulations and documents meant for the public. The board and management must ensure the policies are implemented both in internal management and business operations.</p> <p>(2) The company has set up the “Integrity Operation Procedure Guideline” in accordance with the “Code for Integrity Operations,” which was passed by the board on November 10, 2016 and implemented. The “Integrity Operation Promotion Team” under the board is the dedicated unit for the amendment, implementation, interpretation of this operational procedure and the conduct guidelines, as well as the supervision and implementation of consultation services, report content registration, archiving, and related operations. It periodically reports to the board (at least once a year) and is responsible for the following matters:</p> <p>(A) Assist in incorporating the value of integrity into the company’s operational strategies and set up anti-fraud measures to ensure integrity operations in accordance with the regulatory system.</p> <p>(B) Periodically analyze and assess the risk of dishonest conduct within the business scope and set up plans for preventing “dishonest conduct,” and set up work-related standard operational procedures and conduct guidelines in the plans.</p> <p>(C) Set up a monitoring and balance mechanism for high-risk business activities prone to “dishonest behaviors” within the business scope.</p> | None   |

| Evaluation Item  | Implementation Status |    |   | Deviations from “the Ethical Corporate Management Best-Practice Principles for TWSE/TPEX Listed Companies” and Reasons |
|--|-----------------------|----|---|--|
|  | Yes                   | No | Abstract Explanation  |  |
| (3) Has the company explicitly stipulated and implemented operational procedures, conduct guidelines, violation punishments, and appeal system in the plan for preventing dishonest conduct? Is the abovementioned plan periodically reviewed and revised? |                       |    | <p>(D) Promote and plan integrity operation policy propaganda activities.</p> <p>(E) Plan and implement the offense reporting system to ensure the effectiveness of implementations.</p> <p>(F) Assist the board and management level in checking and assessing whether measures, plans, and mechanisms established to prevent “dishonest conduct” operate effectively, and which are periodically made into reports.</p> <p>(G) Produce and properly keep integrity operation policies and compliance declarations, fulfillment commitment, and implementation situation related documented information.</p> <p>(3) The company’s Integrity Operation Procedure and Conduct Guidelines provision specific integrity operation related practices, definition of dishonest conduct, procedures to comply when providing/receiving/promising interests, internal propaganda/establishment of awards and punishments/appeal system and disciplinary actions, inclusion of integrity operation in the employee performance assessment and human resources policies, and establishment of specific and effective award, punishment, and appeal systems. Management regulations for preventing dishonest conduct include: Management regulations “basic requirements for services,” “award and punishment management guidelines,” “offense reporting operational guidelines,” and declaration of incorruptibility in the recruitment contract duly signed by the employee provisioning incorruptibility clauses including the prohibition of personal fraud, public property misappropriation, public fund embezzlement, bribery commission acceptance, and avoidance of conflict of interest clause to be complied by employees as provisioned. Violations will be dealt with according to the severity of events in order to ensure the company’s integrity operations.</p> |  |

| Evaluation Item   | Implementation Status |    |   | Deviations from “the Ethical Corporate Management Best-Practice Principles for TWSE/TPEX Listed Companies” and Reasons |
|---|-----------------------|----|---|--|
|   | Yes                   | No | Abstract Explanation  |  |
|   |                       |    | <p>As stated in No. 2 of Item (2), the “Integrity Operation Promotion Team” is responsible for periodically analyzing and assessing the risk of dishonest conduct within the business scope, based on which reviews and amendments are carried out. In 2020, the annual review was completed. No anomalies pertaining to dishonest conduct occurred in 2020, and the policy system review situation and supervision implementation results were compiled and reported to the boards in March 18, 2021 (first quarter).</p> <p>(1)~(3) were implemented as provisioned in 2020.</p>  |  |
| <p>2. Fulfill operations integrity policy</p> <p>(1) Does the company evaluate business partners’ ethical records and include ethics-related clauses in business contracts?</p> <p>(2) Has the company set up a dedicated unit to promote enterprise integrity operations and periodically (at least once a year) report to the board regarding the integrity operation policy, the plans for preventing dishonest conduct, and the supervision implementation situation?</p> | V                     |    | <p>(1) Since its beginning, the company has upheld its core policies of “pursue excellence, be honest and accountable, focus on expertise.” Apart from our risk management system (which was built according to laws and accounting regulations), internal control system, and auditing regulations, we also include in our contracts with clients and suppliers terms regarding liabilities and protection of both parties’ rights. We exclude the possibility of insider trading and conduct business fairly and transparently.</p> <p>We have also created the Ethical Management and Behavior Guidelines, which stipulate that before signing contracts with any party, we must fully understand the extent of their business practices. Observation of our ethical business practice policies should be included in contracts, or issues of ethical transactions should be clearly defined in the contracts. After the contracts are checked against the Contract Vetting Methods, they can be approved for signing. There were no dishonest matters from the transacting parties in 2020.</p> <p>(2) In accordance with the provisions in the “Integrity Operation Procedure and Conduct Guidelines,” the company set up the “Integrity Operation Promotion Team” in November 2016 as the dedicated unit under the board for the amendment, implementation, interpretation of the said procedure guidelines, as well as the</p> | None.  |

| Evaluation Item  | Implementation Status |    |  | Deviations from “the Ethical Corporate Management Best-Practice Principles for TWSE/TPEX Listed Companies” and Reasons |
|--|-----------------------|----|--|--|
|  | Yes                   | No | Abstract Explanation   |  |
| (3) Does the company establish policies to prevent conflicts of interest and provide appropriate communication channels, and implement it? |                       |    | <p>supervision and implementation of consultation services, report content registration, archiving, and related operations. The Guideline Regulation Promotion Team periodically reports to the board (at least once a year). In 2020, the annual review was completed, and the “Code for Integrity Operations” and “Integrity Operation Procedure and Conduct Guidelines” were slightly amended. No anomalies pertaining to dishonest conduct occurred in 2019, and the policy system review situation and supervision implementation results were compiled and reported to the boards in March 2020 (first quarter), without anomalies in violation of honesty, disputes, or punishments from the competent authority. The 2020 annual review consolidation report has been completed and reported to the board of directors on March 18, 2021, as follows:</p> <p>(A) In conjunction with the example of the competent authority, the “Code for Integrity Operations” and the “Integrity Operations Procedure and Code of Conduct” have been revised.</p> <p>(B) Online education training (Descriptions of the company’s relevant regulations, legal compliance items, dishonest cases, etc.) and testing.</p> <p>(C) Random audit of dishonest circumstances.</p> <p>(D) Random audit of dishonest circumstances.</p> <p>There were neither abnormal matters in violation of integrity in 2020, nor disputes or punishments by the competent authority.</p> <p>(3) The company’s Basic Service Regulations and “Reward/Penalty Management Methods include avoidance of conflict of interest terms, stipulating that employees should not conduct any business outside of work using the name of the company, take part-time</p> |  |

| Evaluation Item   | Implementation Status |    | Abstract Explanation  | Deviations from “the Ethical Corporate Management Best-Practice Principles for TWSE/TPEX Listed Companies” and Reasons |
|---|-----------------------|----|---|--|
|   | Yes                   | No |   |  |
| (4) Does the company established an effective accounting system and internal control system for implementing integrity operations? Has the internal audit unit formulated relevant audit plans according to the assessment results of dishonest conduct related risks, based on which the situation of compliance with plans to prevent dishonest conduct can be checked, or checking can be implemented by commissioning CPAs? |                       |    | <p>jobs without the company’s permission, and operate or invest in enterprises with business profiles similar to those of the company. The Board Meeting Protocols also have in place avoidance of conflict of interest terms, and the company’s Ethical Management and Behavior Guidelines stipulate that directors, supervisors, managers, and other present stakeholders at the meeting should not participate in discussion or voting, vote on behalf of other directors, or be present when the resolution takes place if matters discussed affect their own interests or interests of those whom they represent. Prior to this, they must explain to the board important points in conflicts of interests, especially when these points negatively affect the company’s interests. Directors should also practice self-discipline and not support each other’s agendas when conflicts of interest occur. Terms above are implemented and supervised by the Task Group for Ethical Management.</p> <p>(4) The company has set up an effective accounting system, internal control system, and related management regulations, while sales, procurements, inspection and acceptance, payments and collections, financial management, investment, and other operations have taken integrity operation objectives into account. The internal audit unit formulated and reported the annual audit plan based on the risk assessment results of various operations, which was passed by the board. Based on the plan implementation audit and annual internal control self-assessment, the effectiveness and compliance situation of the internal control design was reported to the board. The internal control system for 2020 was deemed effective, and no major anomalies were found after implementation inspection. There were no major deficiencies in</p> |  |



| Evaluation Item  | Implementation Status |    |  | Deviations from “the Ethical Corporate Management Best-Practice Principles for TWSE/TPEX Listed Companies” and Reasons |
|--|-----------------------|----|--|--|
|  | Yes                   | No | Abstract Explanation   |  |
| (5) Does the company regularly hold internal and external educational trainings on operational integrity?  |                       |    | <p>the internal accounting control checking report presented by the financial statement CPAs.</p> <p>(5) The company has set up the “Integrity Operation Procedure and Conduct Guidelines,” provisioning that internal propaganda should be conducted yearly to convey the importance of integrity to the directors and employees. Beginning 2020, e-education training has been conducted. During pre-service training for incoming employees, the internal control system and management regulations related to integrity operations are explained.</p> <p>(1)~(5) were implemented as provisioned in 2020, without major abnormalities in violation of integrity operations.</p>  |  |
| <p>3. Operation of the integrity channel</p> <p>(1) Does the company establish both a reward/punishment system and an integrity hotline? Can the accused be reached by an appropriate person for follow-up?</p> <p>(2) Has the company set up investigation standard operational procedures regarding offense reports accepted, subsequent measures to be adopted after investigation completion, and related confidentiality mechanisms?</p> <p>(3) Does the company provide proper whistleblower protection?</p> | V                     |    | <p>(1) On November 10, 2016, the company established its Complaints Protocols, which define complaint and reward systems. The Task Group for Ethical Management is the recipient of complaints.</p> <p>(2) The company’s “Offense Reporting Operational Guidelines” provisions offense report acceptance, confidentiality, appeals, reviews, records, information disclosure, and other mechanisms. An offense report mailbox has been set up on the company’s website and internal website, channels for employees or other stakeholders to file appeals. Subsequent measures to adopt after investigation are as follows:</p> <p>(3) For offense report cases, in case the following events apply, immediately report to independent directors: Events in offense reports involve directors or senior management level, are major violations that subject the company to extensive damage.</p> <p>(3) The company’s Complaints Protocols also establish confidential programs after complaints are received, so that unfair treatment of</p> | None.  |

| Evaluation Item  | Implementation Status |    |  | Deviations from “the Ethical Corporate Management Best-Practice Principles for TWSE/TPEX Listed Companies” and Reasons |
|--|-----------------------|----|--|--|
|  | Yes                   | No | Abstract Explanation   |  |
|  |                       |    | <p>staff can be prevented.</p> <p>In 2020, the above were implemented and fulfilled, and no important violations were found.</p>   |  |
| <p>4. Strengthening information disclosure</p> <p>Does the company disclose its ethical corporate management policies and the results of its implementation on the company’s website and MOPS?</p>   | V                     |    | <p>The Company has set up a corporate website at URL (<a href="http://www.flytech.com">http://www.flytech.com</a>) through which we disclose all sorts of corporate governance related information, including Corporate governance and functional committees, the Company’s regulations, Board of Directors, independent directors, directors as well as the audit head and certified public accountants regarding their in-house communications; the internal audit organization, corporate sustainable operation and CSR to thoroughly implement Ethical Corporate Management Best-Practice Principles, environmental protection and energy saving policies, supplier management, information security management, intellectual property management, risk management and other information. We further disclose such on the official website of the Company regulations or public information observatory including: Code of Corporate Governance, Code of Ethical Conduct, Code of Integrity Management, Corporate Social Responsibility Code, Integrity Management Operating Procedures and Behavior Guidelines and the like.</p> <p>In 2020, the above tasks were verifiably implemented.</p> | None.  |
| <p>5.If the company has established the ethical corporate management policies based on the Ethical Corporate Management Best-Practice Principles for TWSE/TPEX Listed Companies, please describe any discrepancy between the policies and their implementation.</p> <p>The company has created the Ethical Management Principles, Company Ethical Behavior Principles, and Complaints Protocols, all of which are published on the corporate website and Market Observation Post System. They are all in compliance with the Ethical Corporate Management Best Practice Principles for TWSE/GTSM Listed Companies. In 2020, the Task Group for Ethical Management supervised all departments to ensure they were complying with the guidelines, and no violations of ethical management were found. The above findings were reported to the board in the March 2021 meeting.</p> |                       |    |  |  |
| <p>6.Other important information that helps understand the implementation of ethical corporate management of the Company: (e.g. discussion and correction of the Ethical Corporate Management Rules established by the Company):</p>   |                       |    |  |  |

| Evaluation Item   | Implementation Status |    | Abstract Explanation | Deviations from “the Ethical Corporate Management Best-Practice Principles for TWSE/TPEX Listed Companies” and Reasons |
|---|-----------------------|----|----------------------|--|
|   | Yes                   | No |                      |  |
| <p>Based on the Ethical Management Principles, the company has established its Company Ethical Behavior Principles, which was passed by the board on November 10, 2016 and took effect on the same day. The Principles define concrete procedures, behavior guides, penalties for violations, and the complaints system. The task group is directly connected to the board and is responsible for modifying, implementing, explaining, and consulting with regard to the guidelines. Once a year the group will host an announcement event and report to the board, to express to all employees, directors, and supervisors the importance of ethics and the implementation of the principles. The results of the 2019 ethical management were reported at the March 2020 board meeting</p> |                       |    |                      |  |

### 3.3.7 Corporate Governance Guidelines and Regulations

The company's corporate governance regulations include: the Corporate Governance Code, Integrity Management Code, Integrity Management Procedures and Behavior Guidelines, Reporting Methods, Corporate Social Responsibility Code, Ethical Conduct Code, Board Performance Evaluation Methods, Articles of Incorporation, Rules of Procedure for Shareholder Meetings, Rules for the Election of the Directors, Duties and Responsibilities of Independent Directors, Organizational Regulations for the Audit Committee, Rules of Procedure for Board Meetings, Processing Procedures for Major Internal Information, Procedures for Acquisition or Disposal of Assets, Management of Loans to Others, and Procedures of Endorsements and Guarantees. This has been uploaded to the Market Observation Post System, and is also disclosed on the company website's corporate governance section.

### 3.3.8 Other Important Information Regarding Corporate Governance

None.

### 3.3.9 Internal Control Systems

Please refer to the Statement of Internal Control System showed on page 272

### 3.3.10 Major Resolutions of Shareholders' Meeting and Board Meetings

Please refer to the Chinese annual report and official website: <http://flytech.com.tw>.

### 3.3.11 Major Issues of Record or Written Statements Made by Any Director or Supervisor Dissenting to Important Resolutions Passed by the Board of Directors

#### 1. Important resolutions and their implementation status at the 2020 General Shareholders Meeting

- (1) Passed the 2019 Business Operation Report, Accounting Balance Sheet and the remuneration proposal for employees, directors and supervisors.
- (2) Passed the 2019 surplus profit distribution proposal.

Achieved dividend policy balance and stabilization and perfected the financial structure. 10% of the legal reserve of the company's annual surplus in 2019 in the amount of \$73,652,216 was allocated as cash dividends for shareholders in the amount of NT\$572,249,296 in accordance with the Corporate Charter. NT\$4.0 cash dividend per share was distributed. In accordance with Article 241 of the Company Act, Additional paid-in capital in excess of par in the amount of NT\$71,531,162 was distributed as cash dividends. Based on the shares held by shareholders recorded in the shareholder register on the base day of distribution, NT\$0.5 cash dividend per share was distributed.

Implementation status: July 16, 2020 is set as the distribution base date, and all cash dividends were distributed as per the resolution of the general shareholders meeting on August 21, 2020 (NT\$4.5 cash dividend per share).

- (3) Officially passed in the partial amendment to: Articles of Incorporation, Shareholders' Meeting Procedure Rules.

Implementation situation: The regulations shall be announced on the company's official website after meetings and conduction will be in accordance with the amended procedure.

2. 2020 Board meeting and important resolutions by the Board as of the print day of this yearly report

- (1) 2020 proposal to report status of liability insurance for directors and managers
- (2) The "Management Center Vice President Hsieh Sheng-Wen resignation" report case.
- (3) The "Management Center Assistant manager Chan I Wen retirement" report case.
- (4) The "company demonstrates competency in preparing financial statements (four major reports) and all annotated initial drafts for CPA review (approval)" report case.
- (5) Due to market changes and in consideration to overall operational performance, following an assessment, a resolution on cancelling the company registration of Flytech Technology Co., Ltd. (Beijing) and iSAPPOS Systems Company Limited (Hong Kong) was reached.
- (6) Passed the Business Plan in 2020
- (7) Passed the company's 2020 Audit Plan
- (8) Approved the 2019 annual performance bonus (year-end bonus) case approved by the Compensation Committee.
- (9) Passed the "Allot the vice chairman position and nominate director Liu Chiu Tsao for promotion to the vice chairman" case.
- (10) Passed the "Manufacturing Center Senior Vice President Chuo Chun Hung and Marketing Center Vice President Shyu Jia Horng promoted to General Manager under the Dual-leadership system" case.
- (11) Passed the "Division of Finance Vice President Lee Mei Huei promoted to Management Center supervisor" case.
- (12) Passed a proposal to set the 2019 General Shareholders Meeting location, date, and other related issues
- (13) The "Research and Development Center Vice President Teng Chun I resignation" report case.
- (14) The "2019 Board, individual members, and Functional Committee member performance assessment" report case.
- (15) The "2019 Integrity operation implementation situation" report case.
- (16) The "2019 Corporate social responsibility policy implementation situation and stakeholder communication situation" report case.
- (17) The "2019 Information security management situation" report case.
- (18) Passed the 2019 employee remuneration and director remuneration proposals submitted by the Remuneration Committee
- (19) Approved the company's 2019 financial statement (including the consolidated

- financial statement)
- (20) Passed the motion of the distribution of earnings in 2019
  - (21) Approved the Company's distribution of cash dividends in the form additional paid-in capital.
  - (22) Passed the company's 2019 "Internal Control System Announcement", which deems effective the company's Internal Control System Design
  - (23) Passed the amendment on partial articles of internal control system financing cycle "Management Operation Applicable for International Accounting Standards."
  - (24) 4. Approved partial amendments to the "Articles of Association"
  - (25) Passed the amendment on partial articles of "Code for Integrity Operations" and the "Integrity Operation Procedure and Conduct Guidelines)," "Rules for Board Proceedings," and "Rules for Shareholders Meeting Proceedings."
  - (26) Passed the "company's convening the 2020 general shareholders' meeting" motions.
  - (27) The consolidated financial statements covering 2020 Q1.
  - (28) Passed a 2020 proposal to evaluate the independence of accountants in charge of drafting the company's financial report
  - (29) Passing the 2020 Financial Statement Auditor expenses case
  - (30) Officially passed in the partial amendment to "Offense-Reporting Operation Regulations" and "Corporate Social Responsibility Code."
  - (31) Officially passed to disposal of the equity of Qi Jie Electronic (Shenzhen) Co., Ltd. In the disposal process, the Company's subsidiary Pu Da System Co., Ltd. would procure Qi Jie Electronic (Shenzhen) equity through Flytech's offshore holding corporation FTCN BVI in an attempt to enhance the complementary benefits and comprehensive effects of the affiliated enterprises of Flytech Group.
  - (32) The consolidated financial statements covering 2020 Q2.
  - (33) Approved the renewal of the financial credit line case at Chang Hwa Commercial Bank
  - (34) Approved the renewal of the financial credit line case at Cathay United Bank
  - (35) Passed a proposal to apply for a line of credit at HNCB
  - (36) By continuing to provide its subsidiary Box Technologies Limited to apply to Changhua Commercial Bank for a guarantee of a credit line of GBP2 million and authorize the Chairman to handle contract-related affairs.
  - (37) Report about the motion to invest in Zheng Ling Precision Industrial Co., Ltd. with its private placement into domestic unsecured corporate bonds in an amount of NT\$10 million in 2020.
  - (38) Officially passed the Remuneration Committee for the amount of remuneration to directors for 2019.
  - (39) The Remuneration Committee discussed and passed the 2019 Dividend Distribution Plan for Managers and Employees

- (40) Report about the intellectual property management plan and about the implementation in 2020.
- (41) Passed the company's 2021 Audit Plan
- (42) 2021 proposal to report status of liability insurance for directors and managers.
- (43) The motion to invest through FTC BVI into Astra Cloud Holding in its issuance of convertible corporate bonds amounting to US\$100,000.
- (44) Passed the Business Plan in 2021
- (45) Approved the 2020 annual performance bonus (year-end bonus) case approved by the Compensation Committee.
- (46) Passed a proposal to set the 2021 General Shareholders Meeting location, date, and other related issues
- (47) Officially passed the partial amendment to the "Regulations Governing Evaluation of the Performance by the Board of Directors"
- (48) Officially passed the Officially passed of the newly enacted "Risk Management Policy and Operating Rules" and report about the substantial business operation in Year 2020.partial amendment to the "Regulations Governing Evaluation of the Performance by the Board of Directors"
- (49) The "2020 Board, individual members, and Functional Committee member performance assessment" report case.
- (50) The "2020 Integrity operation implementation situation" report case.
- (51) The "2020 Corporate social responsibility policy implementation situation and stakeholder communication situation" report case.
- (52) The "2020 Information security management situation" report case.
- (53) Passed the 2020 employee remuneration and director remuneration proposals submitted by the Remuneration Committee
- (54) Approved the company's 2020 financial statement (including the consolidated financial statement)
- (55) Passed the motion of the distribution of earnings in 2020
- (56) Approved the Company's distribution of cash dividends in the form additional paid-in capital.
- (57) Passed the company's 2020 "Internal Control System Announcement", which deems effective the company's Internal Control System Design
- (58) Approved partial amendments to the "Articles of Association"
- (59) Passed the amendment on partial articles of "Code for Integrity Operations" and the "Integrity Operation Procedure and Conduct Guidelines)," "Rules for Board Proceedings," and "Rules for Shareholders Meeting Proceedings."
- (60) Officially passed the subscription to the capital increase through cash injection of Hua Jie Smart Co., Ltd.
- (61) Officially passed the partial amendment to the "Shareholders' Meeting Procedure Rules" and "Regulations Governing Election for Directors."
- (62) Officially passed the partial amendment to the "Shareholders' Meeting Procedure Rules" and "Regulations Governing Election for Directors."

- (63) Officially passed the reassignment of the Company's spokesman.
- (64) Officially passed the agenda to convene the Company's shareholders' regular meeting for Year 2021.
- (65) Officially passed the lifting of prohibition of business strife from the newly elected directors and the representatives thereof.
- (66) Officially passed the Company's acceptance of nomination by shareholders with more than 1% shares of list of candidates for directors (including independent directors) in the shareholders' regular meeting 2021.
- (67) Officially passed partial amendment to the "Organizational Rules for the Audit Committee" and "Regulations on responsibilities and powers of independent directors" and "Organizational Rules of Remuneration Committee."

### 3.3.12 Resignation or Dismissal of the Company's Key Individuals, Including the Chairman, CEO, and Heads of Accounting, Finance, Internal Audit and R&D

None

### 3.3.13 The facts regarding resignation, discharge in assembling by relevant personnel of the Company (including the chairman, general manager, accounting head, treasurer, internal audit head and research & development head, etc.) in 2020 and as of the date of publication of the Annual Report:

April 10, 2021

| Title                        | Name          | Election Date | Termination Date | Cause of Resignation or Termination       |
|------------------------------|---------------|---------------|------------------|---|
| President                    | Liu Chiu Tsao | January, 2004 | January , 2020   | Promoted to the company's vice chairman.  |
| Vice President of R&D center | Teng Chun I   | August 2018   | February 2020    | Resigned due to personal career planning. |

### 3.4 Information Regarding the Company's Audit Fee and Independence

| Accounting Firm | Name of CPA   |                 | Period Covered by CPA's Audit | Remarks |
|-----------------|---------------|-----------------|-------------------------------|---------|
| KPMG            | Wei-Ming Shih | Yung-Sheng Wang | 2020.1.1~2020.12.31           |         |



Unit: NTD 1,000

| Fee Range |                                | Fee Items | Audit Fee | Non-audit Fee | Total |
|-----------|--------------------------------|-----------|-----------|---------------|-------|
| 1         | Under NT\$ 2,000,000           |           |           | 227           | 227   |
| 2         | NT\$2,000,001 ~ NT\$4,000,000  |           | 3,506     |               | 3,506 |
| 3         | NT\$4,000,001 ~ NT\$6,000,000  |           |           |               |       |
| 4         | NT\$6,000,001 ~ NT\$8,000,000  |           |           |               |       |
| 5         | NT\$8,000,001 ~ NT\$10,000,000 |           |           |               |       |
| 6         | Over NT\$100,000,000           |           |           |               |       |

- (1) The payment for CPA and accounting firm of none audit fee / audit fee reached to 6.5% in 2020

Unit: NTD 1,000

| Firm Name | CPA Name                          | Auditing fee | Non-Auditing fee |                        |                 |       |          | The duration of the audit | Note   |
|-----------|-----------------------------------|--------------|------------------|------------------------|-----------------|-------|----------|---------------------------|--|
|           |                                   |              | System design    | Corporate Registration | Human Resources | Other | Subtotal |                           |  |
| KPMG      | Wei-Ming Shih,<br>Yung-Sheng Wang | 3,506        |                  | 53                     |                 | 174   | 227      | 2020.1.1~2020.12.31       | Others including transfer pricing reports in the amount of \$150,000 |

- (2) For those whose audit public fees on the year of accounting firm change decreased compared to that of the previous year, the amount, ratio, and reason of audit public fees decrease should be disclosed:

The company did not replace the accounting firm in 2020 as of the date of annual report printing.

- (3) Those whose public audit expenses decreased by more than 10% compared to the previous year should disclose the amount of decreased public audit expense, ratio, and reason.

The company's public audit expenses for 2020 amounted to \$3,506 thousands, a slight increase compared to \$3,688 thousands the previous year.

### 3.5 Replacement of CPA:

The company did not replace the accounting firm in 2020 as of the date of annual report printing.

### 3.6 The Company's Chairman, Chief Executive Officer, Chief Financial Officer, and managers in charge of its finance and accounting operations did not hold any positions in the Company's independent auditing firm or its affiliates during 2018.

None.

### 3.7 Transfer of shareholder equity transfer and equity pledge by directors and supervisors, managerial officers and key shareholders holding more than 10% in

## 2020 and as of the date of publication of the Annual Report.

## (1) Changes in Shareholding of Directors, Supervisors, Managers and Major Shareholders

Unit: Shares

| Title   | Name                           | 2020                        |                                      | As of Apr. 30, 2021         |                                      |
|---|--------------------------------|-----------------------------|--------------------------------------|-----------------------------|--------------------------------------|
|   |                                | Holding Increase (Decrease) | IPledged Holding Increase (Decrease) | Holding Increase (Decrease) | IPledged Holding Increase (Decrease) |
| Chairman (major shareholder)  | Lam Tai Seng                   | 205,758                     | —                                    | —                           | —                                    |
| Vice Chairman   | Liu Chiu Tsao (Note 1)         | —                           | —                                    | (30,251)                    | —                                    |
| Director  | Wang Wei Wei                   | —                           | —                                    | —                           | —                                    |
| Director  | Yi Hua Investment              | —                           | —                                    | —                           | —                                    |
|   | Representative: Liaw Jui Tsung | —                           | —                                    | —                           | —                                    |
| Independent director  | Chen Kuo Hong                  | —                           | —                                    | —                           | —                                    |
| Independent director  | Hsieh Han Chang                | —                           | —                                    | —                           | —                                    |
| Independent director  | Liang Wei Ming                 | —                           | —                                    | —                           | —                                    |
| President   | Chuo Chun Hung (Note 1)        | —                           | —                                    | 18,696                      | —                                    |
| President Concurrently serving as the supervisor of the Marketing Center. | Shyu Jia Horng (Note 1)        | —                           | —                                    | 24,118                      | —                                    |
| Assistant Vice President of Marketing Center                              | Hung Dong Chang                | —                           | —                                    | —                           | —                                    |
| Assistant Vice President of Manufacturing Center                          | Chen Chun Hsiung (Note 1)      | —                           | —                                    | —                           | —                                    |
| Vice President of R&D Center  | Liu Yun Ping                   | —                           | —                                    | 30,362                      | —                                    |
| Vice President of Management Center                                       | Lee Mei Huei (Note 1)          | (67,000)                    | —                                    | (17,000)                    | —                                    |
| Assistant Vice President of Manufacturing Center                          | Teng Chun I (Note 1)           | —                           | —                                    | —                           | —                                    |

Note 1: Vice President Teng Chun I of the Research and Development Center resigned on February 29, 2020.

(2) Shares Trading with Related Parties: None.

(3) Shares Pledge with Related Parties: None.

## 3.8 Relationship among the Top Ten Shareholders

April 30, 2021 Unit: Shares

| Name   | Current Shareholding |        | Spouse's/minor's Shareholding |        | Shareholding by Nominee Arrangement |   | Name and Relationship Between the Company's Top Ten Shareholders, or Spouses or Relatives Within Two Degrees |   | Remarks |
|--|----------------------|--------|-------------------------------|--------|-------------------------------------|---|--|---|---------|
|  | Shares               | Shares | Shares                        | %      | Shares                              | % | Name   | Relationship                                    |         |
| Lam Tai Seng   | 16,423,263           | 11.48% | 11,040,443                    | 7.72 % | —                                   | — | Wang Wei Wei   | Spouse  |         |
|  |                      |        |                               |        |                                     |   | Bi Te Investment Zhong Chuan Investment  | First-degree relatives of the company chairman. |         |
| Wang Wei Wei   | 11,040,443           | 7.72 % | 16,423,263                    | 11.48% | —                                   | — | Lam Tai Seng   | Spouse  |         |
|  |                      |        |                               |        |                                     |   | Bi Te Investment Zhong Chuan Investment  | First-degree relatives of the company chairman. |         |
| Fubon Life Insurance Co., Ltd.   | 7,131,000            | 4.99%  | —                             | —      | —                                   | — | None   | None  |         |
| Ji Te Investment Development Co., Ltd.                                       | 4,475,253            | 3.13%  | —                             | —      | —                                   | — | None   | None  |         |
| Representative of Bi Te Investment Development Co., Ltd.: Lin Yi Chung       | 3,840,925            | 2.69%  | —                             | —      | —                                   | — | Lam Tai Seng<br>Wang Wei Wei   | Son   |         |
| MorganStanley investment fund in the custody of HSBC Taiwan                  | 3,117,716            | 2.18%  | —                             | —      | —                                   | — | None   | None  |         |
| Fei Te Investment Co., Ltd.  | 2,581,729            | 1.81%  | —                             | —      | —                                   | — | None   | None  |         |
| Representative of Zhong Chuan Investment Development Co., Ltd.: Lin Yi Chung | 2,422,133            | 1.69%  | —                             | —      | —                                   | — | Lam Tai Seng<br>Wang Wei Wei   | Son   |         |
| Norges Bank in the custody of Citi bank                                      | 2,374,000            | 1.66%  | —                             | —      | —                                   | — | None   | None  |         |
| Lin Yi zhi   | 1,980,668            | 1.38%  | —                             | —      | —                                   | — | Lam Tai Seng<br>Wang Wei Wei   | Daughter  |         |

## 3.9 Ownership of Shares in Affiliated Enterprises

Dec.31, 2020 Unit: Shares; NT\$

| Affiliated Enterprises  | The company's investment |        | Directors, supervisors, managers and investments directly or indirectly controlling the business |        | Comprehensive investment |        |
|---|--------------------------|--------|--|--------|--------------------------|--------|
|   | Shares                   | %      | Shares   | %      | Shares                   | %      |
| Flytech USA International Co., Ltd. (Flytech USA BVI)                         | 100,000                  | 100.00 | —  | —      | 100,000                  | 100.00 |
| Flytech HK International Co., Ltd. (Flytech HK BVI)                           | 50,000                   | 100.00 | —  | —      | 50,000                   | 100.00 |
| Flytech Technology Co., Ltd. CN International Co., Ltd. (Flytech CN BVI)      | 200,000                  | 100.00 | —  | —      | 200,000                  | 100.00 |
| Fei-Syun investment Co. Ltd. (Flytech Investment Co., Ltd.)                   | 19,000,000               | 100.00 | —  | —      | 19,000,000               | 100.00 |
| Box Technologies (Holdings) Ltd. (Box Holdings)                               | 4,000                    | 100.00 | —  | —      | 4,000                    | 100.00 |
| Flytech Technology Co., Ltd. Technology USA Inc. (Flytech USA)                | —                        | —      | 700,000  | 100.00 | 700,000                  | 100.00 |
| Flytech Technology Co., Ltd. Technology (HK) Ltd (Flytech HK)                 | —                        | —      | 1,000,000  | 100.00 | 1,000,000                | 100.00 |
| Flytech Technology (Shanghai) Co.,Ltd (Flytech Technology Co., Ltd. Shanghai) | —                        | —      | Note 1   | 100.00 | Note 1                   | 100.00 |
| WIMIsys Co., Ltd (QIJIE ELECTRONICS)  | —                        | —      | Note 1 ,2  | 100.00 | Note 1 ,2                | 100.00 |
| iSAPPOS Systems Co., Ltd. (iSAPPOS)   | —                        | —      | 6,000,000  | 100.00 | 6,000,000                | 100.00 |
| iRuggy Systems Co., Ltd. (iRuggy Systems)                                     | —                        | —      | 10,354,000   | 49.31  | 10,354,000               | 49.31  |
| Poindus Systems (Poindus system)  | —                        | —      | Note 1   | 100.00 | Note 1                   | 100.00 |
| Berry AI Inc. (Berry AI)  | —                        | —      | 4,200,000  | 70.00  | 4,200,000                | 70.00  |
| Poindus Investment Co., Ltd.  | —                        | —      | Note 1   | 100.00 | Note 1                   | 100.00 |
| Poindus Systems UK Ltd. (Poindus UK)  | —                        | —      | 300,000  | 100.00 | 300,000                  | 100.00 |
| Adasys GmbH Elektronische Komponenten (Adasys)                                | —                        | —      | 2  | 100.00 | 2                        | 100.00 |
| Poindus Systems GmbH GroBhandelmit EDV. Oberureel (Poindus GmbH)              | —                        | —      | Note 1   | 100.00 | Note 1                   | 100.00 |
| Box Technologies Ltd. (box UK.)   | —                        | —      | 10,000   | 100.00 | 10,000                   | 100.00 |
| BTechnologies AB (Box Nordic)   | —                        | —      | 5,000  | 100.00 | 5,000                    | 100.00 |

Note 1: It is a company limited, and thus it has no shares.

Note 2: An Jie System Co., Ltd. proceeded with its liquidation process in June 2020 and completed the liquidation process in February 2021.

## IV. Funding Status

### 4.1 Capital stock and stock shares

#### (I) Source of capital

April 30, 2021 Unit: Shares; NT\$

| Year / month | Issue price | Authorized capital |               | Paid-up capital |             | Note   |                              |         |
|--------------|-------------|--------------------|---------------|-----------------|-------------|--|------------------------------|---------|
|              |             | Shares             | Amount        | Shares          | Amount      | Source of capital  | Offset by assets beyond cash | Other   |
| 1984.08      | 10          | 100,000            | 1,000,000     | 100,000         | 1,000,000   | Capital increase by cash   | None                         | Note 1  |
| 1985.12      | 10          | 250,000            | 2,500,000     | 250,000         | 2,500,000   | Capital increase by cash   | None                         | Note 2  |
| 1988.04      | 10          | 1,000,000          | 10,000,000    | 1,000,000       | 10,000,000  | Capital increase by cash   | None                         | Note 3  |
| 1991.02      | 10          | 6,000,000          | 60,000,000    | 6,000,000       | 60,000,000  | Capital increase by cash   | None                         | Note 4  |
| 2000.11      | 15          | 48,000,000         | 480,000,000   | 18,000,000      | 180,000,000 | Capitalization of retained earnings<br>NT\$ 18,000,000<br>Capital increase by cash<br>NT\$ 102,000,000   | None                         | Note 5  |
| 2001.05      | 30          | 48,000,000         | 480,000,000   | 24,000,000      | 240,000,000 | Capitalization of retained earnings<br>NT\$ 9,000,000<br>Capitalization of capital reserve<br>NT\$ 18,000,000<br>Capital increase by cash<br>NT\$ 33,000,000 | None                         | Note 6  |
| 2002.06      | 10          | 48,000,000         | 480,000,000   | 31,200,000      | 312,000,000 | Capitalization of retained earnings<br>NT\$ 48,000,000<br>Capitalization of capital reserve<br>NT\$ 24,000,000   | None                         | Note 7  |
| 2003.06      | 10          | 48,000,000         | 480,000,000   | 36,348,000      | 363,480,000 | Capitalization of retained earnings<br>NT\$ 51,480,000   | —                            | Note 8  |
| 2004.04      | —           | 48,000,000         | 480,000,000   | 36,503,767      | 365,037,670 | Capitalization of convertible bonds<br>NT\$ 1,557,670  | —                            | Note 9  |
| 2004.11      | 10          | 70,000,000         | 700,000,000   | 42,855,648      | 428,556,480 | Capitalization of retained earnings<br>NT\$ 62,755,650<br>Capitalization of convertible bonds<br>NT\$ 763,160  | —                            | Note 10 |
| 2005.04      | —           | 70,000,000         | 700,000,000   | 43,578,614      | 435,786,140 | Capitalization of convertible bonds<br>NT\$ 7,229,660  | —                            | Note 11 |
| 2005.07      | —           | 70,000,000         | 700,000,000   | 43,691,226      | 436,912,260 | Capitalization of convertible bonds<br>NT\$ 1,126,120  | —                            | Note 12 |
| 2005.10      | 10          | 70,000,000         | 700,000,000   | 49,976,554      | 499,765,540 | Capitalization of retained earnings<br>NT\$ 55,578,610<br>Capitalization of convertible bonds<br>NT\$ 7,274,670  | —                            | Note 13 |
| 2006.01      | —           | 70,000,000         | 700,000,000   | 50,409,189      | 504,091,890 | Capitalization of convertible bonds<br>NT\$ 4,326,350  | —                            | Note 14 |
| 2006.04      | —           | 70,000,000         | 700,000,000   | 51,471,351      | 514,713,510 | Capitalization of convertible bonds<br>NT\$ 10,621,620   | —                            | Note 15 |
| 2006.07      | —           | 70,000,000         | 700,000,000   | 52,567,201      | 525,672,010 | Capitalization of convertible bonds<br>NT\$ 10,958,500   | —                            | Note 16 |
| 2006.09      | 10          | 120,000,000        | 1,200,000,000 | 61,748,395      | 617,483,950 | Capitalization of retained earnings<br>NT\$ 91,811,940   | —                            | Note 17 |
| 2006.10      | —           | 120,000,000        | 1,200,000,000 | 61,798,395      | 617,983,950 | Capitalization of convertible bonds<br>NT\$ 500,000  | —                            | Note 18 |
| 2007.01      | —           | 120,000,000        | 1,200,000,000 | 62,329,645      | 623,296,450 | Capitalization of convertible bonds<br>NT\$ 5,312,500  | —                            | Note 19 |
| 2007.09      | 10          | 120,000,000        | 1,200,000,000 | 73,679,092      | 736,790,920 | Capitalization of retained earnings<br>NT\$ 113,494,470  | —                            | Note 20 |
| 2008.09      | 10          | 120,000,000        | 1,200,000,000 | 83,547,001      | 835,470,010 | Capitalization of retained earnings<br>NT\$ 98,679,090   | —                            | Note 21 |
| 2009.04      | —           | 120,000,000        | 1,200,000,000 | 78,694,001      | 786,940,010 | Cancellation of treasury shares<br>NT\$ 48,530,000   | —                            | Note 22 |
| 2010.09      | 10          | 120,000,000        | 1,200,000,000 | 82,628,701      | 826,287,010 | Capitalization of retained earnings<br>NT\$ 39,347,000   | —                            | Note 23 |
| 2011.01      | —           | 120,000,000        | 1,200,000,000 | 82,633,701      | 826,337,010 | Capitalization of ESO<br>NT\$ 50,000   | —                            | Note 24 |
| 2011.04      | —           | 120,000,000        | 1,200,000,000 | 82,675,701      | 826,757,010 | Capitalization of ESO<br>NT\$ 420,000  | —                            | Note 25 |

| Year / month | Issue price | Authorized capital |               | Paid-up capital |               | Note  |                              |         |
|--------------|-------------|--------------------|---------------|-----------------|---------------|---|------------------------------|---------|
|              |             | Shares             | Amount        | Shares          | Amount        | Source of capital   | Offset by assets beyond cash | Other   |
| 2011.07      | —           | 120,000,000        | 1,200,000,000 | 82,975,701      | 826,957,010   | Capitalization of ESO<br>NT\$ 200,000   | —                            | Note 26 |
| 2011.09      | —           | 120,000,000        | 1,200,000,000 | 90,963,271      | 909,632,710   | Capitalization of capital reserve<br>NT\$ 82,675,700  | —                            | Note 27 |
| 2011.10      | —           | 120,000,000        | 1,200,000,000 | 91,011,697      | 910,116,970   | Capitalization of convertible bonds<br>NT\$ 484,260   | —                            | Note 28 |
| 2012.04      | —           | 120,000,000        | 1,200,000,000 | 91,171,697      | 911,716,970   | Capitalization of ESO<br>NT\$ 1,600,000   | —                            | Note 29 |
| 2012.09      | —           | 120,000,000        | 1,200,000,000 | 100,288,867     | 1,002,888,670 | Capitalization of retained earnings<br>NT\$ 91,171,700  | —                            | Note 30 |
| 2012.10      | —           | 120,000,000        | 1,200,000,000 | 100,303,867     | 1,003,038,670 | Capitalization of ESO<br>NT\$ 150,000   | —                            | Note 31 |
| 2013.01      | —           | 120,000,000        | 1,200,000,000 | 100,424,867     | 1,004,248,670 | Capitalization of ESO<br>NT\$ 1,210,000   | —                            | Note 32 |
| 2013.03      | —           | 120,000,000        | 1,200,000,000 | 103,079,138     | 1,030,791,380 | Capitalization of ESO<br>NT\$ 4,420,000<br>Capitalization of convertible bonds<br>NT\$ 22,122,710 | —                            | Note 33 |
| 2013.07      | —           | 120,000,000        | 1,200,000,000 | 107,035,223     | 1,070,352,230 | Capitalization of ESO<br>NT\$ 4,660,000<br>Capitalization of convertible bonds<br>NT\$ 34,900,850 | —                            | Note 34 |
| 2013.09      | —           | 120,000,000        | 1,200,000,000 | 117,446,863     | 1,174,468,630 | Capitalization of retained earnings<br>NT\$ 104,116,400   | —                            | Note 35 |
| 2013.10      | —           | 120,000,000        | 1,200,000,000 | 119,297,543     | 1,192,975,430 | Capitalization of ESO<br>NT\$ 3,430,000<br>Capitalization of convertible bonds<br>NT\$ 15,076,800 | —                            | Note 36 |
| 2014.01      | —           | 120,000,000        | 1,200,000,000 | 119,965,138     | 1,199,651,380 | Capitalization of ESO<br>NT\$ 200,000<br>Capitalization of convertible bonds<br>NT\$ 6,475,950    | —                            | Note 37 |
| 2014.04      | —           | 180,000,000        | 1,800,000,000 | 120,080,248     | 1,200,802,480 | Capitalization of ESO<br>NT\$ 450,000<br>Capitalization of convertible bonds<br>NT\$ 701,100      | —                            | Note 38 |
| 2014.07      | —           | 180,000,000        | 1,800,000,000 | 120,091,318     | 1,200,913,180 | Capitalization of convertible bonds<br>NT\$ 110,700   | —                            | Note 39 |
| 2014.09      | —           | 180,000,000        | 1,800,000,000 | 132,099,343     | 1,320,993,430 | Capitalization of company reserves<br>NT\$ 120,080,250  | —                            | Note 40 |
| 2014.10      | —           | 180,000,000        | 1,800,000,000 | 132,612,678     | 1,326,126,780 | Capitalization of ESO<br>NT\$ 4,180,000<br>Capitalization of convertible bonds<br>NT\$ 953,350    | —                            | Note 41 |
| 2015.02      | —           | 180,000,000        | 1,800,000,000 | 132,947,202     | 1,329,472,020 | Capitalization of ESO<br>NT\$ 2,220,000<br>Capitalization of convertible bonds<br>NT\$ 1,125,240  | —                            | Note 42 |
| 2015.05      | —           | 180,000,000        | 1,800,000,000 | 138,316,623     | 1,383,166,230 | Capitalization of convertible bonds<br>NT\$ 53,694,210  | —                            | Note 43 |
| 2015.07      | —           | 180,000,000        | 1,800,000,000 | 139,452,492     | 1,394,524,920 | Capitalization of convertible bonds<br>NT\$ 11,358,690  | —                            | Note 44 |
| 2015.09      | —           | 180,000,000        | 1,800,000,000 | 146,368,324     | 1,463,683,240 | Capitalization of capital reserve<br>NT\$ 69,158,320  | —                            | Note 45 |
| 2018.02      | —           | 180,000,000        | 1,800,000,000 | 143,062,324     | 1,430,623,240 | Cancellation of treasury shares<br>NT\$ 33,060,000  | —                            | Note 46 |
| 2020.07      | —           | 220,000,000        | 2,200,000,000 | 143,062,324     | 1,430,623,240 |   | —                            | Note 47 |

Not 1: Approved by the Department of Commerce, MOEA under Notice (73) Shang-Zi No. 138462 dated August 13, 1984.

Not 2: Approved by the Department of Commerce, MOEA under Notice (74) Shang-Zi No. 160682 dated December 4, 1985.

Not 3: Approved by the Department of Commerce, MOEA under Notice (77) Shang-Zi No. 152023 dated April 22, 1988.

Not 4: Approved by the Department of Commerce, MOEA under Notice (80) Shang-Zi No.

- 101879 dated February 11, 1991.
- Not 5: Approved by the Department of Commerce, MOEA under Notice (89) Shang-Zi No. 141350 dated November 9, 2000.
- Not 6: Approved by the Department of Commerce, MOEA under Notice (90) Shang-Zi No. 09001190800 dated May 28, 2001.
- Not 7: Approved by the Securities and Futures Bureau under Notice Tai-Cai-Zheng-Zi (1) No. 0910135158 dated June 27, 2002.
- Not 8: Approved by the Securities and Futures Bureau under Notice Tai-Cai-Zheng-Zi (1) No. 0920128244 dated June 19, 2003.
- Not 9: Approved by the Central Region Office, Ministry of Economic Affairs under Notice Jing-Shou-Zhong-Zi No. 09331996430 dated April 23, 2004.
- Not 10: Approved by the Taipei City Government under Notice Fu-Jian-Shang-Zi No. 09321089910 dated November 3, 2004.
- Not 11: Approved by the Taipei City Government under Notice Fu-Jian-Shang-Zi No. 09408058910 dated April 25, 2005.
- Not 12: Approved by the Taipei City Government under Notice Fu-Jian-Shang-Zi No. 09411451400 dated July 26, 2005.
- Not 13: Approved by the Taipei City Government under Notice Fu-Jian-Shang-Zi No. 09423341100 dated October 14, 2005.
- Not 14: Approved by the Department of Commerce, MOEA under Notice Jing-Shou-Shang-Zi No. 09501018380 dated January 27, 2006.
- Not 15: Approved by the Department of Commerce, MOEA under Notice Jing-Shou-Shang-Zi No. 09501070490 dated April 19, 2006.
- Not 16: Approved by the Department of Commerce, MOEA under Notice Jing-Shou-Shang-Zi No. 09501151620 dated July 14, 2006.
- Not 17: Approved by the Department of Commerce, MOEA under Notice Jing-Shou-Shang-Zi No. 09501211830 dated September 15, 2006.
- Not 18: Approved by the Department of Commerce, MOEA under Notice Jing-Shou-Shang-Zi No. 09501232110 dated October 13, 2006.
- Not 19: Approved by the Department of Commerce, MOEA under Notice Jing-Shou-Shang-Zi No. 09601004100 dated January 9, 2007.
- Not 20: Approved by the Department of Commerce, MOEA under Notice Jing-Shou-Shang-Zi No. 09601231850 dated September 20, 2007.
- Not 21: Approved by the Department of Commerce, MOEA under Notice Jing-Shou-Shang-Zi No. 09701235800 dated September 15, 2008.
- Not 22: Approved by the Department of Commerce, MOEA under Notice Jing-Shou-Shang-Zi No. 09801072810 dated April 14, 2009.
- Not 23: Approved by the Department of Commerce, MOEA under Notice Jing-Shou-Shang-Zi No. 09901204910 dated September 10, 2010.
- Not 24: Approved by the Department of Commerce, MOEA under Notice Jing-Shou-Shang-Zi No. 10001009390 dated January 17, 2011.
- Not 25: Approved by the Department of Commerce, MOEA under Notice Jing-Shou-Shang-Zi No. 10001076400 dated April 18, 2011.
- Not 26: Approved by the Department of Commerce, MOEA under Notice Jing-Shou-Shang-Zi No. 10001154680 dated July 19, 2011.
- Not 27: Approved by the Department of Commerce, MOEA under Notice Jing-Shou-Shang-Zi No. 10001206560 dated September 8, 2011.
- Not 28: Approved by the Department of Commerce, MOEA under Notice Jing-Shou-Shang-Zi No. 10001239630 dated October 19, 2011.
- Not 29: Approved by the Department of Commerce, MOEA under Notice Jing-Shou-Shang-Zi No. 10101072070 dated April 24, 2012.
- Not 30: Approved by the Department of Commerce, MOEA under Notice Jing-Shou-Shang-Zi No. 10101184680 dated September 6, 2012.
- Not 31: Approved by the Department of Commerce, MOEA under Notice Jing-Shou-Shang

- Zi No. 10101214920 dated October 16, 2012.
- Not 32: Approved by the Department of Commerce, MOEA under Notice Jing-Shou-Shang -Zi No. 10201011370 dated January 16, 2013.
- Not 33: Approved by the Department of Commerce, MOEA under Notice Jing-Shou-Shang -Zi No. 10201055210 dated March 27, 2013.
- Not 34: Approved by the Department of Commerce, MOEA under Notice Jing-Shou-Shang -Zi No. 10201141670 dated July 19, 2013.
- Not 35: Approved by the Department of Commerce, MOEA under Notice Jing-Shou-Shang -Zi No. 10201183250 dated September 4, 2013.
- Not 36: Approved by the Department of Commerce, MOEA under Notice Jing-Shou-Shang -Zi No. 10201212520 dated October 18, 2013.
- Not 37: Approved by the Department of Commerce, MOEA under Notice Jing-Shou-Shang -Zi No. 10301007230 dated January 16, 2014.
- Not 38: Approved by the Department of Commerce, MOEA under Notice Jing-Shou-Shang -Zi No. 10301069410 dated April 23, 2014.
- Not 39: Approved by the Department of Commerce, MOEA under Notice Jing-Shou-Shang -Zi No. 10301139430 dated July 14, 2014.
- Not 40: Approved by the Department of Commerce, MOEA under Notice Jing-Shou-Shang -Zi No. 10301185160 dated September 11, 2014.
- Not 41: Approved by the Department of Commerce, MOEA under Notice Jing-Shou-Shang -Zi No. 10301217920 dated October 21, 2014.
- Not 42: Approved by the Department of Commerce, MOEA under Notice Jing-Shou-Shang -Zi No. 10401010400 dated February 6, 2015.
- Not 43: Approved by the Department of Commerce, MOEA under Notice Jing-Shou-Shang -Zi No. 10401080500 dated May 4, 2015.
- Not 44: Approved by the Department of Commerce, MOEA under Notice Jing-Shou-Shang -Zi No. 10401147880 dated July 21, 2015.
- Not 45: Approved by the Department of Commerce, MOEA under Notice Jing-Shou-Shang -Zi No. 10401193810 dated September 22, 2015.
- Not 46: Approved by the Department of Commerce, MOEA under Notice Jing-Shou-Shang -Zi No. 10701017840 dated February 13, 2018.
- Not 47: Approved by the Department of Commerce, MOEA under Notice Jing-Shou-Shang -Zi No. 10901110340 dated July 09, 2020.

April 30, 2021; Unit: shares

| Share category                             | Authorized capital |                 |             | Note |
|--|--------------------|-----------------|-------------|------|
|  | Outstanding shares | Unissued shares | Total       |      |
| Common shares listed in the stock exchange | 143,062,324        | 76,937,676      | 220,000,000 | —    |

## (2) Shareholders structure

April 30, 2021; Unit: shares; %

| Shareholders structure  | Government institutions | Financial institutions | Other corporations | Foreign institutions and foreigners | Individuals | Total       |
|-------------------------|-------------------------|------------------------|--------------------|-------------------------------------|-------------|-------------|
| Volume                  |                         |                        |                    |                                     |             |             |
| Head count              | 0                       | 7                      | 70                 | 104                                 | 12,800      | 12,981      |
| Number of shares held   | 0                       | 11,869,238             | 22,071,467         | 17,648,444                          | 91,473,175  | 143,062,324 |
| Shareholding percentage | 0.00 %                  | 8.30 %                 | 15.43 %            | 12.33 %                             | 63.94 %     | 100.00 %    |



## (III) Ownership diversification

Ordinary shares: face value NT\$ 10 per share. (The Company has not issued preferred shares)

April 30, 2021

| Shareholding rank           | Number of shareholders | Number of shares held | Shareholding percentage % |
|-----------------------------|------------------------|-----------------------|---------------------------|
| 1 to 999 shares             | 2,945                  | 671,640               | 0.48%                     |
| 1,000 to 5,000 shares       | 7,719                  | 16,156,863            | 11.29%                    |
| 5,001 to 10,000 shares      | 1,204                  | 9,020,526             | 6.31%                     |
| 10,001 to 15,000 shares     | 397                    | 5,008,247             | 3.50%                     |
| 15,001 to 20,000 shares     | 196                    | 3,521,822             | 2.46%                     |
| 20,001 to 30,000 shares     | 180                    | 4,436,254             | 3.10%                     |
| 30,001 to 40,000 shares     | 92                     | 3,265,263             | 2.28%                     |
| 40,001 to 50,000 shares     | 52                     | 2,374,126             | 1.66%                     |
| 50,001 to 100,000 shares    | 93                     | 6,644,176             | 4.64%                     |
| 100,001 to 200,000 shares   | 42                     | 5,460,913             | 3.82%                     |
| 200,001 to 400,000 shares   | 27                     | 7,952,242             | 5.56%                     |
| 400,001 to 600,000 shares   | 9                      | 4,191,475             | 2.93%                     |
| 600,001 to 800,000 shares   | 3                      | 1,937,097             | 1.35%                     |
| 800,001 to 1,000,000 shares | 3                      | 2,835,125             | 1.98%                     |
| 1,000,001 or over           | 19                     | 69,586,555            | 48.64%                    |
| Total                       | 12,981                 | 143,062,324           | 100.00%                   |

## (IV) List of major shareholders: shareholders with shareholding exceeding 5% or shareholders with top 10 shareholding percentages

April 30, 2021

| Name of major shareholder   | Shareholding<br>Number of shares held | Shareholding<br>percentage % |
|---|---------------------------------------|------------------------------|
| Lam Tai Seng  | 16,423,263                            | 11.48%                       |
| Wang Wei Wei  | 11,040,443                            | 7.72%                        |
| Fubon Life Insurance Co., Ltd.  | 7,131,000                             | 4.99%                        |
| Ji Te Investment Development Co., Ltd.  | 4,475,253                             | 3.13%                        |
| Bi Da Investment Development Co., Ltd.  | 3,840,925                             | 2.69%                        |
| Manage data software and information management, integrate software and hardware service. | 3,117,716                             | 2.18%                        |
| Fei Te Investment Co., Ltd.   | 2,581,729                             | 1.81%                        |
| Zhong Chuan Investment Development Co., Ltd.  | 2,422,133                             | 1.69%                        |
| Invesco Funds SICAV – Invesco Asian Balanced Funds in the custody of HSBC                 | 2,374,000                             | 1.66%                        |
| Lin Yi zhi  | 1,980,668                             | 1.38%                        |

## (V) Market price, net value, earnings, dividend per share and related information in the last 2 years

Unit: NT\$; thousands shares

|                                |   | Year                  | 2019    | 2020    | As of 2021/04/30 |
|--------------------------------|---|-----------------------|---------|---------|------------------|
|                                |   | Item                  |         |         |                  |
| Market price per share         | Highest                                       |                       | 82.3    | 76.5    | 69.5             |
|                                | Lowest  |                       | 66.5    | 52.9    | 58.6             |
|                                | Average                                       |                       | 74.36   | 65.95   | 63.34            |
| Net worth per share            | Before dividend distribution                  |                       | 30.78   | 30.30   | 30.90            |
|                                | After dividend distribution (Note 1)          |                       | Note 2  | Note 2  | —                |
| Earnings per share             | Weighted average shares (in thousands shares) |                       | 143,062 | 143,062 | 143,062          |
|                                | Earnings per share (ex-right)                 |                       | 5.15    | 4.12    | —                |
| Dividends per share (Note 2)   | Cash dividend                                 |                       | 4.5     | 4.0     | —                |
|                                | Stock dividends                               | From earnings         | 0.0     | 0.0     | —                |
|                                |   | From capital reserves | 0.0     | 0.0     | —                |
|                                | Retained Dividends                            |                       | —       | —       | —                |
| Analysis of investment returns | P/E ratio (Note 3)                            |                       | 14.44   | 16.01   | —                |
|                                | Price to dividends ratio (Note 4)             |                       | 16.55   | 16.49   | —                |
|                                | Cash dividend yield (Note 5)                  |                       | 6.05    | 6.07    | —                |

Note 1: The resolution of the Shareholders Meeting for the next year on the distribution of income.

Note 2: The motion on the distribution of stock dividends in 2020 has been passed by the Board of Directors in a session dated March 18, 2021 pending the final approval of the Shareholders Meeting.

Note 3: P/E ratio = Average closing price per share for the year / earnings per share.

Note 4: Price to dividend ratio = Average closing price per share for the year / cash dividends per share.

Note 5: Cash dividend yield = Cash dividend per share / average closing price per share for the current year.

## (VI) The company's dividend policies and execution

## 1. Dividend policies

The Shareholders Meeting resolved on June 8, 2018 to amend the Articles of Incorporation in the aspect of dividend policy specified as follows:

- (1) If the Company has earnings after the annual account settlement, it shall appropriate for the payment of applicable taxes and covering carryforward loss, followed by the appropriation of 10% as legal reserve, and appropriate for the special reserve where necessary and as required by law. If there is still a balance, it shall pool up with the undistributed income accumulated in previous periods for distribution at the proposal of the Board, subject to the final approval of the Shareholders Meeting. The amount of distribution shall not fall below 60% of the corporate earnings net of the offsetting of

carryforward loss, appropriation for the legal reserve, and the special reserve.

- (2) The Company takes into account equilibrium and stability in making its dividend policy, and in conjunction with the specific nature of the overall environment and the development of the industry with consideration of long-term financial planning and satisfaction of cash flow needs of the shareholders. Likewise, cash dividend shall not fall below 10% of the total cash dividend and stock dividend resolved to distribute in the year.

## 2. Execution status

The shareholder meeting intends to approve the 2020 annual surplus distribution proposal drawn up by the board of directors on March 18, 2021. According to the company's articles of incorporation, issued the shareholders' cash dividends of NT\$ 500,718,134 at NT\$ 3.5 per share after listing the 10% legal reserve of NT\$ 58,872,576. Additionally issue additional paid-in capital of NT\$ 0.5 per share in cash.

### (VII) Impacts on business performance and earnings per share if the stock dividend proposal is approved during the annual general meeting

| Item/year  |   | 2020 (estimates)             |
|--|---|------------------------------|
| Paid-in capital at the beginning of the period (NT\$1,000) |   | 1,430,623                    |
| Stock Dividend in the current period                       | Cash dividend per share (NT\$) (Note 1)   | 3.5                          |
|  | Number of shares allotted for each share held under the capitalization of retained earnings into new shares (Note 1)                                | 0                            |
|  | Number of shares allotted for each share held under the capitalization of additional paid-in capital (Note 1)                                       | 0.5                          |
| Changes in business performance                            | Operating profit  | NA<br>(Note 2)               |
|  | Proportion of change in the operating income from the same period of the previous year (%)  |                              |
|  | Net profit after tax  |                              |
|  | Proportion of change in net income from the same period of the previous year (%)  |                              |
|  | Earnings per share (NT\$)   |                              |
|  | Proportion of change in EPS from the same period of the previous year (%)   |                              |
| Pro forma EPS and P/E ratio                                | If the retained earnings for capitalization into new shares were switched to payment of a cash dividend in the full amount                          | Pro forma EPS (NT\$)         |
|  |   | Pro forma annual average ROI |
|  | If there was no capitalization of additional paid-in capital  | Pro forma EPS (NT\$)         |
|  |   | Pro forma annual average ROI |
|  | If there was no capitalization of additional paid-in capital and the entire amount of retained earnings were switched to payment of a cash dividend | Pro forma EPS (NT\$)         |
|  |   | Pro forma annual average ROI |

Note 1: Resolved by the regular session of the Shareholders Meeting in 2021.

Note 2: According to the “Regulations Governing the Publication of Financial Forecasts of Public Companies”, the Company is not required to disclose its financial forecasts in 2020.

(VIII) Remuneration for employees, directors and supervisors

1. The percentage or scope of remuneration to the employees, Directors, and Supervisors as stated in the Articles of Incorporation:

Article 23 of the Company’s Articles of Incorporation states that the company should offer 3%-15% of the profits as employee compensation and no more than 3% of the profits as compensation to directors if the company is profitable that year. This is subject to a special resolution meeting by the board of directors and it should be reported during the shareholder meeting. Remuneration to employees may be paid in cash or stock. The recipients include the employees of subsidiaries meeting specific conditions. However, when the company still has accumulated losses, an amount equivalent to the loss should be reserved for making up the loss.

The company board passed the “director and employee remuneration distribution case” on March 18, 2021. The remunerations for employees were estimated according to the profitability in 2020 and in reference to the distribution ratios in previous years. The actual remunerations distributed to directors were estimated in reference to the employee performance assessment results and KPI achievement situation. The remunerations for directors were estimated in reference to amounts distributed in previous years and the 2020 board performance assessment results. The actual amounts distributed were in reference to the annual performance assessment results of the directors. If there is a difference between the estimated amount and the actual issued amount, it will be treated as changes in accounting estimates and enter accounts when issuing annual adjustments.

2. The estimation of remunerations to the employees and Directors for the current period was based on the calculation of the quantity of shares distributed to the employees and the actual amount paid, and the accounting of the difference between the estimates and the actual payment:

The estimated amount of compensation for employees and directors/supervisors in 2019 will included in the operating costs or expenses based on their natures. If the allotted amount decided during the shareholder meeting is different from the estimated number on the financial statements, then it will be listed as changes in estimates for the current period’s net income or losses.

3. The approved distribution of compensation on March 18, 2021 by the

board of directors is as follows:

- (1) The differences, reasons and handling of the estimated amount and actual compensation amount for employees and directors in cash or stocks is as follows:

The cash remunerations for employees totaled \$51,500,000, and the remunerations for the directors totaled \$3,500,000, showing no differences in estimated credited amount in the 2020 financial statement. In 2020, no remunerations were distributed through shares.

- (2) The amount of payment to employees in the form of stocks in proportion to the net income stated in the separate financial statements in proportion to the total amount of remuneration to the employees:

No release of stocks as remuneration to the employees in the current period

4. The actual payment to the employees, Directors, and Supervisors in the previous year (including quantity of shares, amount, and stock price):

The cash remunerations for employees totaled \$77,000,000, and the remunerations for the directors totaled \$3,500,000, showing no difference in estimated credited amount in the 2020 financial statement. In 2030, no remunerations were distributed through shares.

(IX) Shares repurchased by The Company: None

**4.2 Execution status of issuing corporate bonds:** None.

**4.3 Issuance of preferred shares:** None.

**4.4 Disclosure relating to depository receipts:** None.

**4.5 Status of employee stock certificates:** None.

**4.6 The new shares from restricted employee stock option:** None.

**4.7 Disclosure on new shares issued in exchange of other company shares:** None.

**4.8 Progress on the use of funds**

(I) Content of the plan

As of the end of the 1<sup>st</sup> quarter prior to the printing of this report, uncompleted offering of securities in tranches or through private placement, or offering of securities that was completed but the purpose of the plan has not been realized in the last 3 year: N/A.

(II) Execution:

Not applicable

## V. Operation overview

### 5.1. Business content

(I) Business scope:

1. Business scope:

(1) Major contents:

The design, manufacturing, and sale of industrial computers and related peripherals.

(2) Business proportion:

Unit: NT\$ 1,000

| Item \ Year          | 2019      |              | 2020      |              |
|----------------------|-----------|--------------|-----------|--------------|
|                      | Amount    | Percentage % | Amount    | Percentage % |
| Industrial computers | 3,434,820 | 87.47        | 2,901,451 | 88.49        |
| Peripherals          | 468,312   | 11.93        | 353,478   | 10.78        |
| Other (Note)         | 23,601    | 0.60         | 23,804    | 0.73         |
| Total                | 3,926,733 | 100.00       | 3,278,733 | 100.00       |

Note: Others are revenues from the development and designed project to the appointment of the customers.

(3) The carrying items of products (services) and new products (services) of the Company planned for development

① Premium items of the Company:

All-in-one POS, Panel PC, Mobile POS, KIOSK, box PC, and POS Monitors.

② New products planned for development:

New specifications All-in-one POS, Panel PC, Mobile POS, KIOSK, box PC, and POS Monitors, Non-POS represent the brand-new products instead of PC application-oriented products, cloud software platforms and such series.

(II) Industry overview

1. Present state of the industry and development

(1) POS System

The POS system is a type of customized product aiming at the specific needs of the users in design, and is different from the standard specification mass production mode of consumer

electronics such as the PC industry. The main targeted group of customers is system integration service providers and value adding distributors. For meeting the diversified specification standards of the firms and the wide array of customization in software, hardware manufacturers must have the capacity of integrating high stability and quality, and flexible design in manufacturing. As such, the high added value of the POS industry comes from the quality and service of the firms, and there is a relatively high entrance barrier and less likelihood to confront cut-throat competition from other competitors. The evolution of the information communication technology (ICT) compelled the leading firms of the industry to use technologies in satisfying the newly developed needs of the customers. The All-in-one Touch POS multiple function touch control screen has been used extensively in food and beverages, hotels, retail and department stores, supermarkets, lottery and entertainment, distribution services, finance and banking, and other service industries to provide the timely functions of massive sale, inventory, customer information inquiry, computing, analysis and management. The sustainable innovative function and well-developed hardware integrated technology allowed the entrance of POS into the extensive Point-of-Service application sector. The latest innovative AI has also become an important part of application in smart retailing, smart restaurants, and smart cashier service and related high added value services. The variety of new stimulations and the continued expansion of the demand market will continue to drive the POS industry toward further growth.

The popular application of mobile products in the market of consumer electronics, and the rise of the ideas of the IoT, cloud computing, and smart living provided ground for the stable and mature development of mobile product core technologies such as related hardware computing speed, system software, and wireless information communication. These devices provide a description of portable devices, product search, inventory inquiry, data search, portable account settlement printout, transmission of information to terminal servers and related functions, and could flexibly be used in different industries in a diversity of functions including acceleration service, no constraint of time and space, avoidance of account settlement over-the-counter, portable services, and other high added value services. It is still the biggest driving force for continuously pushing the Point-of-Service industry into a brand new application market.

In 2020 the global domination was under the haze of the

COVID-19 pandemic led to a gigantic impact on the global economic development, in particular the catering and retail industry. Flytech and customers jointly faced the market impact and both developed new application business opportunities to cope with the severe market challenges. In 2020, the Company's POS machine, in terms of shipment volume, continued to rank in the leading position among the world's top three and Taiwan's No. 1 market position.

## (2) Industrial Computers-Panel PC and KIOSK

In the industrial computer sector, Panel PC integrates the system, hardware and monitor into a space saving panel. Panel PC is a solid device featuring water resistance, dust proof, shock proof and tamper-proof, and could be easily integrated to needs, energy efficient, light weight, and portable to meet application needs, and provides the best integrated services. Currently, this item has been extensively used in industrial control/medical devices/security control/traffic control/restaurant kitchens/transport vehicles/outdoor exhibition and others in an environment of mobility, high dust, high temperature, and humidity. The proper development of wireless network infrastructure allows Panel PC to provide a diversity of applications through data transmission from a server at the remote end that makes a much wider scope of applications available, including industrial control, medical use, commercial use, public information service, transportation, table reservation and ticket booking, e-home, games, KVS, and gaming and similar markets.

Artificial intelligence (AI) and automation trends are the most important technological innovation and revolution, while related applications are undergoing overwhelming development. It is expected that the future industrial development must combine AI applications to create more advanced smart convenience. Under this trend, related system products will also be widely applied to the application end. The company's second production line Panel PC will also be applied in smart medicine, smart engineering control, smart management, and other related fields, while consumers' preference and demand for self-service has opened up new markets for KIOSK widely applied in newly set self-service routes of general stores and unmanned store check-out machine products.

Amidst the harsh challenge of the COVID-19 pandemic in 2020, Flytech accurately dominated the up-to-date needs in the medical industry and changes in consumer behavior patterns, responded in a timely manner and successfully developed medical application product series and launched mass production shipments,



turning the crisis into a turnaround. In the future, Panel PC and KIOSK will still be pioneered by the Company through application of innovation of important product series into golden business opportunities.

2. The association of industries from upstream to downstream

The premium items of the Company are POS System, Panel PC, Mobile POS, and PC POS. The upstream industry is similar to PC and the key components are LCD/LED Panel, Touch screen, CPU, Chipset, DRAM, Storage device, PCB, logic IC, passive components, Power adapter, and input/output device. The downstream industry is different from PC and varies with customers. Most of them are system integration service providers, value adding distributors, or ODM customers and hardly sold directly to consumers. The following chart shows the association of the upstream, midstream, and downstream industries:

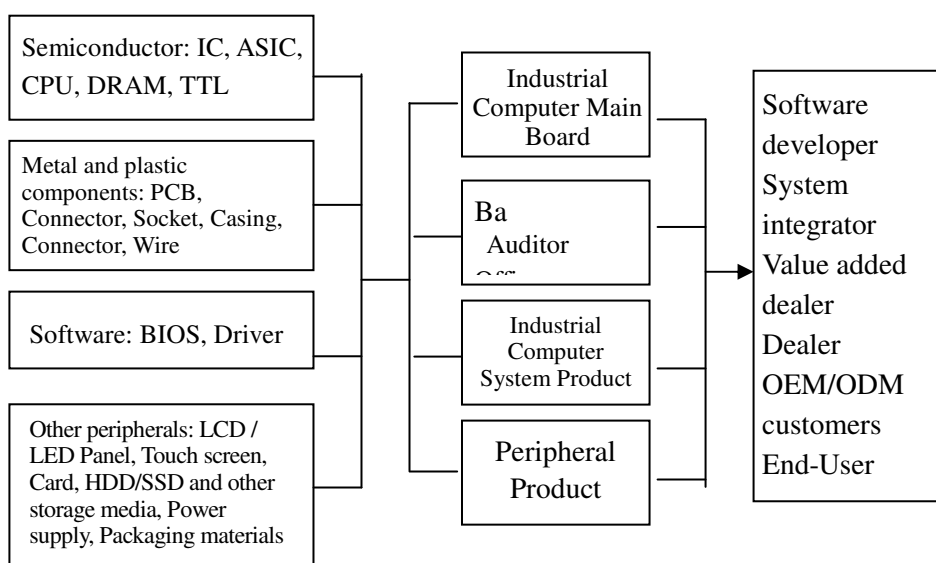

3. Trends of development of various products and competition

The features of the premium products of the Company:

(1) POS System

We are ahead of the industry peers in professional customized POS design, know-how and development of production process, and pioneered the trend of hardware specification in the POS industry. We have 84 patented intellectual property rights through in-depth development and innovation in technology. We were the first to invest in the POS market as early as 1999. From 2002 onwards, POS has emerged as the premium item of the Company. Accordingly, we positioned ourselves for selling projects for enterprises and international giant firms as our marketing strategy

and provide research and development design, manufacturing, and service, and aim to emerge as a first rate international professional POS (Point-of-Service) hardware designer and manufacturer. The Company has launched a series of Touch POS integrated with touch control and LCD into one device since 2003, and integrated the peripherals into a Customer Display POS system. Currently, the key item for shipment is the 4<sup>th</sup> generation All-in-one Touch POS with touch control screen. From 2009 onwards, the Company has committed resources to the research and development of a micro embedded system platform for developing integrated devices with different screen sizes and processors with different levels of performance, and upgraded customized design with higher flexibility so that the system integration service providers could develop markets in a much broader horizon (highly acclaimed by the customers) and expand the business territory. The Company launched the PTS (Payment Terminal Solution) series in 2015, and effected mass production shipment in 2016. This move turned the traditional image of POS upside down. With the built-in thermal inductance paper printer, the touch control panel could be used as a tablet PC and also provides function as a desk-top printer. This will be an ideal item for the payment intermediaries with its compact appearance, portable application and price advantage, and will help the Company to penetrate into the market of the small shopping malls and shops which would otherwise be difficult for the launch of POS products, and develop the leasing or purchase market of a single device for the micro business.

In the wake of the rapid development of technologies and different needs of applications at the customer end, the application of smart POS systems is becoming increasingly diversified. We launched the 1<sup>st</sup> generation Mobile POS system at the 2014 COMPUTEX. This device performs the function of payment integration, and is a brand new item for mobile service in smart cities under the latest trend of development around the world. We also launched the new generation Mobile POS 274 in the 2018 COMPUTEX by matching Mobile POS with Wi-Fi and 3G module, MSR, IC card reader (accredited by EMV Level 1.2), Scanner, NFC, fingerprint, and related settings. This device performs the IP54 water repellent and resistance function, with long-life and replaceable battery, and could be used in conjunction with other mobile card reading devices and printing equipment to provide a description of a portable item, product search, inventory inquiry, data search, portable account settlement printout, and transmission

of information to terminal servers. This item could be used flexibly in a number of industries for a simplified consumption process and occupies very little space for high added value portable service. Series of peripherals for using in iOS have also been developed so that customers can get a viable solution through fingerprint unlocking, mobile payment, and linking to peripheral equipment.

With the expansion of market demand for mobile products, the company launched a new Mobile POS series in 2019. The new products successfully overcame the space constraints of application sites, providing “code-scanning table ordering services weigh speedy connection and excellent quality and receiving positive feedback and orders from well-known international brands, thereby creating more application momentum for the POS system product series of Leyte has Technology Co., Ltd.

We make our own design from MB, and have 4 SMT process lines and perfect quality control systems since the operation started at the newly built facilities in Hwa Ya Technology Park. The vertical operation is completed in a single process from MB to the finished device. As compared with other suppliers, we are more seasoned and stable in research and development, production technology, and customization. We also have complete product lines with widely spread price ranges, high/mid/low-end models with different specifications and options for different solutions of different markets. We are ready to accept purchase orders from international giant firms and customization of projects for customers.

In 2020, the impact by COVID-19 upon the global catering and retail industry was virtually beyond description. Flytech and its customers jointly faced market impact and tried hard to develop new application business opportunities as a countermeasure. For instance, in order to provide more innovative value-added service functions, Flytech in 2020 successfully launched the software known as Inefi, a sort of hardware monitoring service virtually enabling customers to remotely monitor the operation of machines and peripheral accessories as well as remote control. This highly value-added function was believed to help customers save considerable maintenance costs. Flytech, as well, continually expanded its functions in response to market needs in order to provide customers with the most complete software value-added services. Flytech starts from the very innovation point to respond to severe economic challenges and market tests.

As always, we take the “Design For Service, Design for Cost, and Design for Quality” as the principal axis of POS design. Further

to the continued expansion in the markets of Europe, Asia and America as well as the newly emerging economies for export, we also are continuing in the market of domestic demand and Greater China. Our core competence includes: serious commitment to the customers, unique product strategy, key professional technologies, good professional experience in systems, flexible manufacturing capacity, quick and good quality service, exclusive market positioning, proper market segmentation, and the development of high value-added differentiated products in different areas of applications. Our complete product lines could provide quick and good quality customized services including product design, manufacturing, supply management, and post-delivery service. The scope of services covers Point-of-Service value chain that differentiates us from our industry peers in market segmentation to avoid malicious competition. In the future, the Company will continue to provide full-range customized service packages with an attempt to secure more orders for enterprise projects and international giant firms, and form strategic alliances with these international giant firms so as to emerge as a benchmark enterprise of “Point-of-Service hardware Systems” with “complete product line, advanced know-how, outstanding manufacturing, and strong partnership commitment”.

## (2) Industrial Computers-Panel PC and KIOSK

In the domain of industrial computers, the Panel PC is the product that integrates the system, hardware, and monitor into one device. The condensed, slim, and sturdy single board features simplicity in integration, energy efficient, light weight, and fool proof in assembly, and can be used in small or limited spaces, outdoors, as a mobile loading tool, and environments with wide fluctuations in temperature, humidity and impact, or dusty and can provide simple and easy integration service. The Company has successfully developed a series of Panel PC products, including the Bedside Terminal, a joint venture with international well-known manufacturers for using in ambulances and short-range care platform. The shipment volume of this item remains stable and can be used in information management/hospital bed management/hospital bed caring/inquiry of medical history in electronic format, and as telephone/video call/multimedia/network/inquiry/meal ordering services for the patients in clinics and hospitals. The customized designed and good quality allow the successful entrance of this item into the niche

market of exclusive medical use with a substantial market share in the medical care industry where increasing demand for quality service is the trend.

The company has also successfully developed Panel PC series products that come in a full range of sizes and diverse functions for various automation applications, including catering, industrial control, commercial use, transportation, public information services, such as meal and ticket ordering, e-home, games, gaming, and other fields of innovative applications. The company's products developed through R&D have achieved industry-leading IP67-waterproof grade. The company launched the K770 series at the Embedded World 2016 Exhibition & Conference with the use of SUS304 food and medical-grade stainless steel, a flat multi-point touch screen, Intel's latest BayTrail® Processor, and IP69K-waterproof grade testing certified by SGS, and 1Grms anti-shock and 20G anti-collision testing to provide customers with the most complete solutions. The products are suitable for food processing plants, restaurants and kitchens, and medical equipment applications; the K740 series provided embedded applications with the Intel BayTrail® Processor. The front panel passed IP66 waterproof grade testing and is applicable for harsh automated plant environments. The USB and switch are located at the front panel and have covers that can be closed and locked, so as to prevent an accidental bump under the operational environment that accidentally turns the machine on/off or unauthorized driver data transmission. The NFC/RFID/WiFi/Bluetooth are located at the front panel to optimize their signal transmission interface. There is an independent I/O port that has passed anti-full testing. In addition to focusing on the industrial automation market, it can also be applied in medical products and commercial applications, providing enterprise users with the best industrial computer choice; the K750 product series is a flat 32" 10-point touch tablet PC with projected capacitance, with the latest Intel Skylake Processor. It provides a wide range of expansion functions and I/O interface intended for medical institutions and operation rooms, giving customers more diversified specifications, accommodating various installation sites, and offering solutions for differentiated applications.

In addition to the Panel PC machines, the company also successfully developed self-service KIOSK applied in unmanned stores, airport self-check in, and hotel self-check in/out machines. In 2019, the new-generation ultra-slim KIOSK solution was launched. It is not only in line with the ADA (American Disability Act)

barrier-friendly design, but also has achieved zero shaking with the total weight reduced by more than half compared to other models available in the market, with substantive performance in well-known brand shipments.

With the development of artificial intelligence (AI) and industrial applications reaching maturity, the company has actively engaged in R&D combined with AI and innovative products with automation functions. In 2019, subsidiary Berry AI was established, and AI and deep learning related software technology R&D commenced, leading to the successful development of AI recognition check-out product service machines and providing a new speedy self-check-out experience, thereby creating new market demands with high added value.

Amidst 2020 while the world was hit hard by the COVID-19 pandemic. Flytech saw the crisis turning into a turnaround. We took advantage of the increased demand for medical resources to vigorously develop new business horizons and new products and successfully won the purchase orders of the respirator Panel PC. On the one hand, we paved the way for the expansion of sales in medical-related industries in the future. On the other, we continually increased the differentiation of our product portfolio. The Panel PC series and KIOSK represent the Company's second largest business entities, innovating product features with the latest technology along with applying innovative developer machines. Using customized, differentiated, excellent quality and good service to strive for cooperation projects with well-known counterparts is an important success factor for our Company to stabilize the niche in the market.

### (III) Technology and R&D Overview

1. The R&D expenditure in the last 5 years to the date this report was printed.

Unit: NT\$ 1,000

| Year            | 2016    | 2017    | 2018    | 2019    | 2020    | Up till April 30,<br>2021 |
|-----------------|---------|---------|---------|---------|---------|---------------------------|
| R&D expenditure | 189,051 | 194,757 | 189,990 | 169,628 | 158,736 | 56,886                    |

## 2. Technologies or products successfully developed in the most recent year

| Date of completion | R & D results  |
|--------------------|--|
| 2018               | 1. Successfully developed industrial computer series and new peripherals (POS system, Mobil POS, Panel PC, KIOSK, PC POS system): P337N2、P655、T605A+、K75D、K959、PB99、PB81、PB82、PB85、PB88、K85B<br>2. Successfully developed new MB series: D01、D42、D42L、D86S、D87U、D89S   |
| 2019               | 1. Successfully developed industrial computer series and new peripherals (POS system, Mobile POS, Panel PC, KIOSK, PC POS system) : P617, P667, P337, K757V, P274 P roject machines, K865, K86B, K889 K959, PB88, PC12 P155N<br>2. Successfully developed new MB series: D01, D42, D42L, D86S, D87U, D89S  |
| 2020               | 1. Successfully researched and developed industrial computers (POS system, Mobil POS, Panel PC, KIOSK, PC POS system, and Non-PC) series and new peripheral products: P615, P665, P617N, P667N, PB96, M276, M278, K736, K737, K738, K739, K889, PC17, PC18, PC26<br>2. Successfully developed new MB series: D98, F12, F14, F16, F63U, F64U, F93, F93S |

## (IV) Long and short-term business development plans

## 1. Short-term development plan

## (1) Marketing strategy

- ① Develop different applications with different products, extend different applications in the depth and scope of products (restaurants/hotels/supermarkets/superstores/retailers/price inquiry/ticketing/food ordering/shopping/multimedia advertising/medical use/industrial control/traffic control/gaming) for enlargement of the territory of Point-of-Service product line application.
- ② Keep abreast and control of the trend of smart application technology and respond to the needs of mobility and self-service of the industry, launch new Mobile POS products capable of integrating payment and KIOSK products for using in unmanned shops, multilateral expansion to different applications with diversified product lines, and continue to develop innovative application markets. Furthermore, we focus on more diverse fields so that customers from all walks of life would have the best intelligent solutions. Such vast fields include Animal husbandry farms, food processing mills, electric vehicle factories, medical

places and Internet of Things applications.

- ③ With the wealth of experience in system integration and flexible production under customization accumulated for years, we will continue to secure more orders for enterprise projects and international well-known brands for the effective use of differentiated R&D design, rapid manufacturing, superior quality, cost control and related core competence to heighten the entrance barrier against the competitors.
- ④ Invest to establish subsidiaries for the pursuit of branding strategy and development of sale channels for new products. Provide resources to the subsidiaries in the mode of a “central kitchen”, keep up with the core competence including the development of advanced technologies, product design approximating market needs, procurement of key components, and flexible production and manufacturing, and continue to provide the customers with the best service.
- ⑤ Focus on key customers and develop potential customers. Design and develop a new style and multi-functional niche items for the customers, and assist the customers to broaden their scope of applications, boost sales, and increase market share.
- ⑥ Acquire overseas subsidiaries through equity control for expansion with their brand marketing expertise, existing clientèle base, and channels in Europe for yielding synergy under the vertical integration of supply chain.
- ⑦ Based on the successful sale experience in Europe and America for further development into the markets of Asia, Greater China, and newly emerged economies. Establish regional market strategic partnerships to develop local markets for new customers through the service platform of the partners, and provide quick service for the customers.

## (2) R&D and Production Policy

- ① We introduced cost management in design in the R&D phase aiming at simplicity, sturdiness, and practicality to develop the most efficient physical and electronic design. With the use of shared modules and the convergence of key components and materials in the specification to align with the strategic purchase



plan for adaptation to the changes in the material supply market.

②The Company introduced a full-range of products in alignment with the global market trend. In the R&D phase, the Company adopted green design to mitigate the impact on the environment. Through green procurement, the Company moved the environmental protection requirements upstream to the supply of components and materials. This move was also extended to the entire life cycle of the product from the process of use to treatment after dumping.

③From the perspective of the users, we established an effective quality assurance system through SOP for strengthening the control of design quality/part quality/production process quality. From R&D to shipment, we upgraded the product quality throughout the full range with strict selection of parts/full-range/product inspection and validation.

④With the use of high-efficiency and high-quality automated equipment for significant enhancement of stability and capacity of production. With the use of a self-development production process management system, we could bolster process planning and scheduling management for the flexible use of production capacity, and perform flexible adjustment of scheduling and modularized production in line with the volume and content of purchase orders to enhance production efficiency and cost reduction. We provide customers with high quality services and products from design/production to post-delivery service through extensive and intact integration.

(3) The scale of operation is congruent with the financial position:

①The corporate headquarters in Taiwan serves as the base for R&D and production with globalization and in-depth local marketing through the subsidiaries in Taiwan, the UK, USA, Hong Kong, and Mainland China, as well as the strategic partners in different regions.

②The Company seeks to root in Taiwan with its corporate headquarters in Neihu Technology Park and proprietary plants located at Hwa Ya Manufacturing Center at Linkou Technology Park, which was completed in 2011, and bolster its global logistics mechanism and financial operation stability with an upgrade in

operation efficiency.

- ③ We will further our efforts in operation with innovative products and application functions, upgrade the capacity of the management team for in-depth development of the product market and competitive advantage of our core competence.
- ④ We will create a positive training environment to provide the opportunity of continuing education in professional skills and internal control for the new and existing employees so as to upgrade their quality and improve coordination and communication, which in turn will help to enhance the overall operation performance.

## 2. Long-term development plan

### (1) Marketing strategy

- ① We positioned ourselves as a “Service Manufacturer” with “a complete product line, advanced know-how, outstanding manufacturing, and strong partnership commitment”. Under the corporate philosophy of honesty and integrity in business, and commitment to the stakeholders, we cultivated a profound partnership with the customers and provide product planning and post-delivery service with global, multilateral, and completed service and customized products.
- ② The corporate headquarters at Neihu Technology Park is the global logistics and R&D center, while the new facility at Hwa Ya in Linkou Technology Park is the manufacturing center. These two centers working in conjunction with the business locations at home and overseas in the form of strategic alliance could enlarge the business territory through in-depth development with key customers and supply of the best innovative design and manufacturing services. We also positioned ourselves as a hardware supplier to assist customers develop niche products for better business opportunities and markets, and emerge as a first class professional system manufacturer of the world.
- ③ Integration with the technologies, products, application software and channels of the partner firms through strategic alliance in combination with the advantages of R&D and production in the

industry, as well as the advantages of strategic partnership and technologies, we could create the soundest performance.

- ④ Through the subsidiary's new technology APP R&D, machines with new specifications that combine new Apps have undergone development.
- ⑤ The Company will increase its market share through the brand marketing and new sale channels of the subsidiaries.
- ⑥ The Company will continue to develop new products, applications, and function from an innovative and differentiated perspective, and take sustainable growth in business performance as the perpetual goal.
- ⑦ We aimed at the global market and will continue to expand the markets with innovative applications to strengthen the cooperation with the distribution and value adding distributors, and launch products of high/mid/low-end to different market segments with different positioning in different regions of applications for broadening the foundation of sales.

## (2) Production policy and product development direction

- ① The Company will aim at the industry with innovation and high profit through proper market segmentation and positioning to improve the added value of products and keep abreast of key technology and professional experience to develop customized niche products with high added value.
- ② Development of models that could be used in different environments such as Desktop, Wall mount, Tower, Mobile, Mini, and Self Service and continuation in improving the embedded function and speed, innovative application areas, strengthening the design of physical appearance ID, and pioneered products in diversity and with competitive power in the innovative market.
- ③ Targeting niche products from the high/mid/low-end product lines with the supply of the best models and customized service for diversified applications. In addition, the Company will design high quality and high added value standard item series, provide quick delivery service, and emerge as the best choice for the small and medium size customers so as to maximize the results of

production, sales, research and development.

- ④Horizontalization of the organization helps to improve decision-making and execution of policies. Through the tight combination of upstream to downstream process including product planning, R&D, material control, procurement, warehouse management, manufacturing and quality control, the Company could provide a flexible production schedule through quick and accurate response.
- ⑤With the control of production, quality and delivery process on shop floors with timely feedback and records, the Company can bolster process planning and scheduling management and upgrade capacity efficiency and overall product quality to satisfy customer needs.
- ⑥The Company will continue the proper implementation of the ISO 9001 quality system, the ISO13485 product quality system of medical devices, and ISO 14001 environmental management system, and get closer to the customers through its exclusive technical support window by providing quick and good quality service. The Company will also fortify its customer service function for higher customer satisfaction, and improve the application capacity of the customers with the products and hence develop better business opportunities for related products.
- ⑦Gradually increased the proportion of Non-POS products and continually develop cloud service software.

(3) The scale of operation is congruent with the financial position

- ①With customized service and outstanding R&D and production capacity, the Company designed a wide array of niche products for the customers to increase its market share. It was matched with the series of standard items with added value for expanding the business territory of the small and medium size customers for creating revenue growth.
- ②Continue the proper implementation of the internal control system, internal audit system, and budget management for the overall improvement of operation efficiency.
- ③Continue the advocacy of corporate governance and focus in

innovation and in-depth development of the operation under the corporate philosophy of honesty and integrity and sustainability in development to create value for the shareholders, employees, customers, suppliers and other stakeholders where all are the winners.

- ④ Effective control of inventory levels, costs, and expenses with the budget system and performance indicator management for revenue growth and higher rate of return.
- ⑤ Integration of all group enterprises on the basis of the scale of operation of the Company and the MIS system developed on the basis of the flexible production mode, and the information systems of the parent company and subsidiaries all over the world for multilateral logistics control of corporate resources and operation management. In addition, the Company seeks to implement the ISO 27001 information system in full effort to augment the security management of information assets.

## 5.2. Market and production and sales overview

### (I) Market analysis

#### 1. The regions for the sale of premium products

Unit: NT\$ 1,000

| Region \ Year   |                   | 2019      |              | 2020      |              |
|-----------------|-------------------|-----------|--------------|-----------|--------------|
|                 |                   | Amount    | Percentage % | Amount    | Percentage % |
| Domestic demand |                   | 300,982   | 7.66         | 404,459   | 12.34        |
| Export          | American          | 1,936,531 | 49.32        | 1,634,296 | 49.85        |
|                 | Europe and Africa | 1,287,372 | 32.79        | 942,177   | 28.74        |
|                 | Asian             | 401,848   | 10.23        | 297,801   | 9.07         |
|                 | Subtotal          | 3,625,751 | 92.34        | 2,874,274 | 87.66        |
| Total           |                   | 3,926,733 | 100.00       | 3,278,733 | 100.00       |

#### 2. Market share, the supply/demand and growth of the market in the future

##### (1) POS System

In the wake of the ceaseless innovation and diversification of technologies, application areas, and function, the early definition of POS (Point-of-Sales), which was simply focused on the management of the sale and inventory system, has been surpassed

by POS (Point-of-Service) designed with the integration of different application services. The target market not only includes the traditional restaurant business, hotels, retailing and distribution but also the diversity of commercial activities including food, clothing, transportation, education, and entertainment, even in the computer systems for industrial control, medical and healthcare, transportation, security control, and military use, and the smart functions of combining AI and automation management. The PC-based POS system could be linked to the back-end database and front-end operating system to achieve the objective of rapid control of sale and inventory information to precision management. The Touch POS that combined touch control screen and multiple functions in one device is the mainstream item for the time being. It features real-time data gathering/inquiry/processing/computing and interactive function, and is an indispensable tool for competition in business. The space for the growth of the POS business is growing perpetually in line with the ceaseless enlargement of the scope of application. It also triggers the needs for innovation. The evolutionary development of innovative technologies and the ever changing needs of the customer end has triggered the demand for innovative applications of a smart POS system. Realizing the exploding growth of the market of mobile items, the Company launched the Mobile POS in 2014 for a new horizon of POS application needs by combining the embedded module with mobile peripherals to provide portable service functions of product description, product search, inventory inquiry, data search, account settlement printout, and transmission of data to the terminal server, and is attuned to the latest mobile payment trend. The Company has pioneered the Point-of-Service business into an innovative and brand new market. In 2017, the Company developed the patented product, System Diagnostic Recorder (SDR), and corresponding cell phone APP. With this item, users could keep the key parts and components of the POS system under control with the use of the cell phone APP. Accordingly, users could just use their cell phone to control key parts and components, system CPU, cooler fan speed and system temperature. The Brand new application specification will bring about momentum for the demand of the POS market. With the rapid development of demand for Mobility products, the

company launched the new Mobile POS series in 2019 to respond to the mobile market demand. The new products provide “code-scanning ordering at the table” service with excellent connection speed and quality, successfully receiving orders from customers (well-known international brands) and commencing shipments. With the brands’ store development in Asian regions, the company has gained market recognition and sound sales performance. The company also developed a series of smart retailing, smart catering, smart check-out, and other new high value adding applications applied on the POS system to meet the demand. The Company has also developed a series of smart retailing, smart restaurant, smart account settlement, and related high added value innovative applications in line with the development of AI.

The upgrade of the POS system application triggered the vigorous demand for replacement of new devices, and led to the continued expansion of the global market for replacement of new devices. In 1999, the Company was the first manufacturer in Taiwan to engage in the development of a POS exclusive device. The core competence includes: complete product line, the wealth of experience in system integration, the capacity in R&D of customization and engineering technology, successful cost control and supply chain management, multiple-line flexible production scheduling, stable quality, perfect customer service, and flexible sales strategy. The Company assisted the customers to prepare the most differentiated products at high customization level, specification from high to low-end, with competitive power in price, and quick delivery. Notwithstanding the effect by the COVID-19 epidemic in 2020 that suggests a considerable impact upon the catering and retail industry, Flytech teamed up with customers to face the market impact hand-in-hand and develop new application business opportunities to cope with the severe market test. In 2020, our Company’s shipped POS machines were continually to maintain within the top three in the world and firmly ranking proud No. 1 in Taiwan.

## (2) Industrial Computers-Panel PC and KIOSK

A Panel PC is a slim light single board device combining the

system, hardware, and monitor. It is light and compact in style, easy to integrate, energy efficient, light weight, and highly mobile without any constraint in time and space, and could provide durable and diversified application integration and interactive services.

In the wake of the evolution of ICT, proper development and stability of product technology, and the diversification of application functions, the sustained and rapid development of Panel PCs required a new market. “Medical service” is an area of innovative application with promising growth, among others. Seeing that the combination of advanced technology and good quality service will be an irreversible trend of development in the market of medical care products, the Company engaged in a joint venture with an internationally well-known firm to develop the Bedside Terminal, a successful device for the exclusive use in the medical care sector accredited with the ISO13485 medical system quality. This device is a compact Panel PC that allows the patients to use computer/Internet/telephone/video call/multimedia/food order/information search and tracking medical records for hospital room management/hospital bed caring/managing bedside medical records and history in an electronic format, and could be used in ambulances or as a remote healthcare platform, and has been highly accepted by the users. The Company will continue to develop a new generation of such devices for mass production shipment. The launch of this item is a success and the Company has received orders from many internationally well-known medical device manufacturers for developing different models for medical care control and has effected mass production shipments. The Company has also launched a series of Panel PC products further to medical use devices. These products were made from food and medical grade stainless steel, passed the water resistance, tamper-proof, impact resistance tests, with the best signal transmission interface in physical design, and the abundance of expandable function and I/O interface for adaptation to different rough environments such as: food processing industry/restaurant kitchens/medical equipment/factory automation/security control/traffic control/public information service/transportation/outdoor exhibition/KVS/gaming/food ordering and ticket reservation/eSports/e-home and others for continued development of Panel PC demand market. In addition to Panel PC, the shipments of KIOSK machines used in unmanned stores, airport self-check in, and hotel self-check in/out have also gradually increased. In 2019, the new-generation ultra-slim KIOSK solution was launched. It is



not only in line with the ADA (American Disability Act) barrier-friendly design, but also has achieved zero shaking with the total weight reduced by more than half compared to other models available in the market, which successfully received large orders from chain stores in North America with representative significance. Mass shipments commenced beginning 2019, successfully seizing the market domain.

In addition, with the development of artificial intelligence (AI) and industrial applications gradually reaching maturity, the company established subsidiary Berry AI. Specialized in AI and deep learning software technology, combined with the parent company's complete product line and professional integration technology and the retail catering industry's rich channeling, goods shipments have commenced, with positive feedback from customers. The company will continue to create more demand momentum's and provide smart retailing, smart catering, smart checkout, and other high value adding services that cater to market needs.

During 2020, while the entire world was hit extremely hard by the COVID-19 pandemic, Flytech successfully controlled the new needs of the medical industry and the changes in consumer behavior patterns. We responded well in real time, successfully developing multiple medical application product series and mass production shipments, turning the crisis into a brilliant opportunity. The company will uphold Point-of-Service's years of R&D integration capabilities and manufacturing experience, with different industry-based innovative applications as the starting point to design specifications in line with various industry-based installation environment requirements, continue to expand new business opportunities in different application fields, and create the best customized machines with a compact appearance, durability, excellent quality, reasonable price, and diversified applications, which are expected to continue to seize the industrial computer market domain.

Based on the analysis of the overall market supply side, it shows that the POS system, Panel PC, and KIOSK are all highly customized products produced according to customers' specifications and all under the high-gross-profit niche market. The mass production economic scale itself is not the main competitive advantage, it is the individual customers' suppliers whose product

application side of R&D technical capabilities in providing package solutions, customized and flexible production capabilities, new function R&D capabilities through new technologies, quality stability, and the provision of good after-sales services that constitute the primary factors for the supply-side competing vendors' market share. The company has accumulated years of experience in mature technology for system integrations and applications and has extensive experience in the flexible production of customized products, with good quality control and after-sales services, thus the good word-of-mouth in the market and high customer loyalty, which make up the customer's niche to achieve market share expansion.

From the demand side, the evolution of technological development, the ever changing innovative application and the quest for an electronic version, and technological innovation brought about industrial innovation that triggered the continued development of new demand market. Where the entire world market was hit hard by the COVID-19 pandemic, the demand in some industries decreased. Nevertheless, new demand such as the medical industry increased against the trend. The market momentum shifted but did not disappear. Flytech's 2020 sales growth of Panel PC and Mobile POS is the proof. In the future, Flytech will grasp the market demand and respond promptly to continually develop related new products, invest in related new technology development, continue to cooperate with sales partners in various countries throughout the world on the sales channel, and acquire new customers. The crisis is also a turned into a turnaround.

3. The competitive edge, factors favorable and unfavorable for development in the long run, and responses
  - (1) Competitive edge
    - ① Optimistic outlook of business opportunity for the industry
    - ② Proper market positioning
    - ③ Completed product lines
    - ④ Wide-ranged price products and diversity in specifications from high to low-end devices.
    - ⑤ Flexibility, quick response and stable quality in customized

technologies

- ⑥ Proper control of fundamental technologies and system integration technology
- ⑦ Professional marketing, R&D, and manufacturing team
- ⑧ Flexible sale strategies and sounded sales channel
- ⑨ Firm commitment to the customers, suppliers, employees, shareholders and all stakeholders: “completed product lines, advanced know-how, outstanding manufacturing, and strong partnership commitment”.

(2) Factors favorable and unfavorable for development in the long run, and responses

① Favorable factors:

- A. Innovative design, positioning in niche market
- B. Short delivery lead-time in stable quality
- C. A well-organized R&D, marketing, and manufacturing team
- D. Control key R&D and manufacturing integration technology
- E. Flexible and efficient use of production capacity
- F. Proper control of cost
- G. Flexibility in marketing
- H. Complete product lines with expandability and wide range of applications
- I. Customized customer service, promise to customers and strong long-term cooperative relation
- J. Long-term and stable product supply

② Unfavorable factors:

Customized production is a form of small quantity production. The scale of production of one item is incomparable to mass production of standard items. As such, the cost of production and price for purchase of part will be relatively higher.

Responses:

- A. Promotion through modularized projects and engagement in joint venture with system integration service providers for mitigating the impact from price competition.

- B. Design customized items with a competitive advantage in the market with high added value for the customers and provide technical solutions to intensify the differentiation from standard items, and avoid price competition with industry peers.
- C. Tighten cost control from the design end, and introduce shared use of materials and modularized design to enlarge the scale of purchase for particular item of materials to achieve a better bargaining position.
- D. Control the cost and inventory of key parts and components through strategic purchase.
- E. Offer mass production standard items to small and medium size customers for holding the cost down and bringing up profit.
- F. Intensify the service to key customers and potential customers, develop new and profitable areas of application and niche products, and create innovative business opportunities for Flytech and the customers.

(II) The function and production process of key products

1. The function of key products:

| Product name   | Primary scope of application   |
|--|--|
| POS system<br>All-in-One POS、<br>PC POS、<br>Mobile POS | Areas of mobile applications such as chain stores/distribution industry/the cashier system of superstores, ordering and cashier system of restaurants, counter system of airlines/hotels, lottery machine of pleasure and entertainment industry, mobile food ordering/portable data search and account settlement.  |
| Industrial computer<br>Panel PC、KIOSK、<br>KPC          | Commercial and public information equipment, multimedia advertising, human-machine interface automation mechanical control, medical equipment, touch control display, industrial control, security control, transportation, touch control game and entertainment. Multimedia information inquiry system, unmanned retailer, self-service devices, multimedia sample audition device, self-service photo development device, self-service room reservation and food ordering value storage system, self-service/multimedia interactive service and self-service product identification. |
| Peripherals  | Card reader, customer display.   |

2. The manufacturing process of key items

(1) Self-manufactured and outsourced semi-finished items:

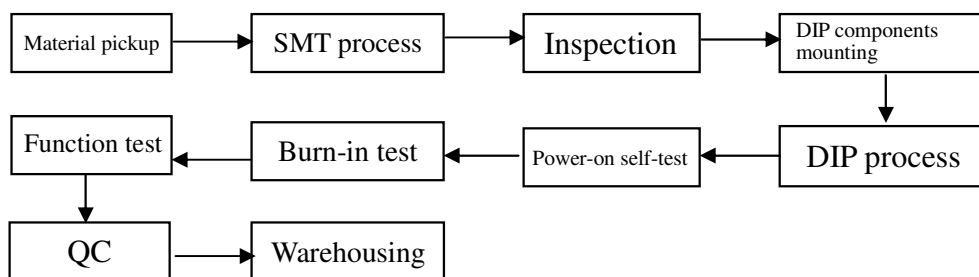

(2) Self-manufactured and outsourced system server:

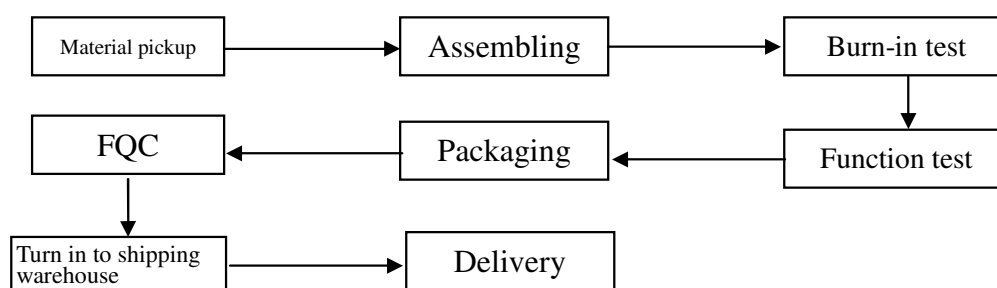

3. The supply of key materials

The key materials of the Company are electronic materials, physical part materials, and packing materials, including: LCD/LED Panel, Touch screen, CPU, Chipset, DRAM, Storage device, PCB, Power adapter, metal and plastic physical parts. For electronic materials, some IC semiconductors, LCD/LED Panels were purchased from abroad, and most were purchased from domestic suppliers. The physical metal and plastic structure were designed by the Company and produced by outsourced domestic suppliers after tooling. The diversification of the source of purchase is the strategy used for purchase with domestic suppliers or agents for assuring the diversity of supply and higher flexibility of price with stable and reliable sources of supply.

4. List of key customers for purchase and sale

(1) Information on suppliers accounted for more than 10% of the total purchase of the Company in the last 2 years to 2021 Q1:

Unit: NT\$ 1,000

| Item | 2019         |           |                                       |                               | 2020         |           |                                       |                               | 2021 to the end of Q1 (note) |        |  |                               |
|------|--------------|-----------|---------------------------------------|-------------------------------|--------------|-----------|---------------------------------------|-------------------------------|------------------------------|--------|--|-------------------------------|
|      | Name         | Amount    | Ratio to net purchase in the year (%) | Relationship with the company | Name         | Amount    | Ratio to net purchase in the year (%) | Relationship with the company | Name                         | Amount | Ratio to net purchase in the year to the end of Q1 (%) | Relationship with the company |
| 1    | Synnex       | 406,663   | 18.60                                 | None                          | Synnex       | 270,318   | 14.07                                 | None                          | —                            | —      | —  | —                             |
| 2    | Other        | 1,779,609 | 81.40                                 | None                          | Other        | 1,650,909 | 85.93                                 | None                          | —                            | —      | —  | —                             |
| 3    | —            | —         | —                                     | —                             | —            | —         | —                                     | —                             | —                            | —      | —  | —                             |
|      | Net purchase | 2,186,272 | 100.00                                | —                             | Net purchase | 1,921,227 | 100.00                                | —                             | —                            | —      | —  | —                             |

Note: As of April 30 2021, audited financial information covering 2021 Q1 was still unavailable.

## (2) Note to the changes

The Company produces industrial use computers and there is a great variety of its parts and components. In light of the finer line of professional division of labor, IC suppliers are mostly agents or distributors. The other suppliers of electronic, electrical, or physical parts and components are mostly manufacturers. There is a wide array of parts and components in several brands and the purchase has been evenly distributed among the suppliers that none accounted for particular high or low share of total purchase.

## (3) Information on customers accounted for more than 10% of the total sale in the last 2 years to 2021 Q1:

Unit: NT\$ 1,000

| Item | 2019        |           |                                   |                               | 2020        |           |                                   |                               | 2021 to end of Q1 (Note) |        |  |                               |
|------|-------------|-----------|-----------------------------------|-------------------------------|-------------|-----------|-----------------------------------|-------------------------------|--------------------------|--------|--|-------------------------------|
|      | Name        | Amount    | Ratio to net sale in the year (%) | Relationship with the company | Name        | Amount    | Ratio to net sale in the year (%) | Relationship with the company | Name                     | Amount | Ratio to net sale in the year to the end of Q1 (%) | Relationship with the company |
| 1    | TI          | 775,764   | 19.76                             | None                          | TI          | 750,912   | 22.90                             | None                          | —                        | —      | —  | —                             |
| 2    | AG          | 468,766   | 11.94                             | None                          | Other       | 2,527,821 | 77.10                             | None                          | —                        | —      | —  | —                             |
| 3    | Other       | 2,682,203 | 68.30                             | None                          |             |           |                                   |                               | —                        | —      | —  | —                             |
|      | Sales - net | 3,926,733 | 100.00                            | —                             | Sales - net | 3,278,733 | 100.00                            | —                             | —                        | —      | —  | —                             |

Note: As of April 30 2021, audited financial information covering 2021 Q1 was still unavailable.

## (4) Note to the changes

The Company is a professional manufacturer of industrial computer hardware and the key customers are hardware brands, system integration service providers, agents and channel marketers, corporate program/projects, and international well-known giant firms. The decrease in revenue compared to the previous year is due to the completion of the project. The changes in key customers in the last 2

years are explained below:

- ① TI is a POS hardware brand.
- ② AG is a major channel France marketer for the Company.

#### 5. Production value and volume in the last 2 years

Unit: NT\$ 1,000- set

| Year   | 2019                       |         |           | 2020                       |         |           |
|--|----------------------------|---------|-----------|----------------------------|---------|-----------|
|  | Production capacity (Note) | Volume  | Value     | Production capacity (Note) | Volume  | Value     |
| Production value and volume Premium products |                            |         |           |                            |         |           |
| Industrial computers                         | 250,000                    | 216,572 | 2,331,602 | 250,000                    | 190,662 | 1,991,974 |
| Peripherals                                  | —                          | —       | 356,081   | —                          | —       | 266,016   |
| Total  | 250,000                    | 216,572 | 2,687,683 | 250,000                    | 190,662 | 2,257,990 |

Note: Annual production capacity of front-end MB along the production process and cards of the Company is at 600,000 pieces. The back-end assembly line process is system integration service and varied with individual projects and orders for flexible production of various types of products with maximum capacity of 600,000 units.

#### 6. Sale volume and value in the last 2 years

Unit: NT\$ 1,000- set

| Year                                   | 2019           |         |         |           | 2020           |         |         |           |
|--|----------------|---------|---------|-----------|----------------|---------|---------|-----------|
|  | Domestic sales |         | Export  |           | Domestic sales |         | Export  |           |
|  | Volume         | Value   | Volume  | Value     | Volume         | Value   | Volume  | Value     |
| Sale volume and value Premium products |                |         |         |           |                |         |         |           |
| Industrial computers                   | 14,211         | 217,799 | 193,592 | 3,217,021 | 23,718         | 344,323 | 158,913 | 2,557,127 |
| Peripherals                            | —              | 80,265  | —       | 388,047   | —              | 58,732  | —       | 294,746   |
| Other (Note)                           | —              | 2,918   | —       | 20,683    | —              | 1,404   | —       | 22,401    |
| Total                                  | 14,211         | 300,982 | 193,592 | 3,625,751 | 23,718         | 404,459 | 158,913 | 2,874,274 |

Note: Others are revenues from the development and designed project to the appointment of the customers.

#### 5.3 Number of employees in the last 2 years to the date this report was printed.

Unit: person

| Year                 |   | 2019       | 2020       | Up till April 30, 2021 |
|----------------------|---|------------|------------|------------------------|
| Number of employees  | Production                                | 238        | 191        | 194                    |
|                      | Research and Development                  | 86         | 91         | 91                     |
|                      | Sale                                      | 48         | 50         | 50                     |
|                      | Administration                            | 48         | 48         | 49                     |
|                      | Total                                     | 420        | 380        | 384                    |
| Average age          |   | 40.31      | 40.79      | 40.56                  |
| Average seniority    |   | 7.92 years | 8.30 years | 8.12 years             |
| Education Background | Masters and higher                        | 16.43 %    | 18.68 %    | 18.49 %                |
|                      | College                                   | 46.67 %    | 52.63 %    | 51.04 %                |
|                      | Senior high schools and vocational school | 28.10 %    | 22.63 %    | 24.74 %                |
|                      | Junior high schools and below             | 8.81 %     | 6.05 %     | 5.73 %                 |

#### 5.4 Environmental expenditure information

- (I) Total amount of loss (including compensation for damages) and fines caused by environmental protection in the last 2 years to the date this report was printed, the remedies and possible expenditure: None.
- (II) Projected expenditures on environmental protection in 3 years ahead: Our Neihu Corporate Headquarters is scheduled to replace the entire air-conditioning systems within 2021 to replace R-22 refrigerant with a more environmentally friendly R410-a. After completion of the replacement project, the annual HCF emission will be reduced from 14.9 kg to 10.5 kg, and the carbon emission equivalent will drop from 26.9 metric tons down to 20.2 metric tons. Thanks to such effort, we expect to save about 100,000 kWh of electricity consumption annually.
- (III) The company has set the “Code for corporate social responsibility” and obtained international environment management system ISO14001 certification in 2011 (passed the certificate reviewing in 2019; the 2015 version (validity period from September 22, 2019 through September 21, 2022)). During the product design stage, the purpose of reducing environmental impacts was achieved through energy-saving and environmental protection green design and the low-pollution manufacturing of environmentally friendly consumables. In the area of procurement, the Company extends its environmental protection requirements to the production process and materials adopted by upstream suppliers through supplier management and green purchase. In the area of production, the specific nature of the industry of the Company allows for no water and air pollution in the production process of products. A lead-free process has been introduced all through the production process. All parts conform to RoHS of the EU and are accredited under RoHS. The Company also duly observes applicable laws and intensifies the recycling and reuse of resources, and prevents the pollution of water and air through proper monitoring and testing through its waste management plan. Furthermore, the Company also advocates a carbon reduction and energy saving, and proceeds to sustainable development of the environment by mitigating the impact on the environment to the expectation of the international trend and customers. The aforementioned activities have been implemented through the Company’s “Corporate Social Responsibility Committee” and the promotion offices thereunder to continuously supervise the implementation of the five sub-sections to fulfill corporate social responsibility. For details, please refer to the “2019 CSR Report” published by the Company on the Company’s official website.



(IV) The company commenced self-inspection of greenhouse gas emission beginning 2015, has formulated management strategies, methods, goals, and carbon emission reduction goals, and continues to conduct monitoring and improvement. Management policies pertaining to energy conservation, carbon reduction, greenhouse gas emission, water usage reduction, or other waste and their implementations are explained below:

1. Greenhouse Gas Management Strategies and method

The company's greenhouse gas emissions fall under indirect emissions, and the carbon dioxide emissions generated from power use are the company's main source of greenhouse gas emissions. The energy conservation and carbon reduction plan should focus on saving electricity.

- (1) In terms of production processes: Motor operation control optimization is done, and relevant production waste is handed to a certified recycling unit for disposal in order to reduce its impact on the overall environment.
- (2) Encourage employees to propose an energy conservation and carbon reduction plan.
- (3) In terms of daily operations:
  - Replace lighting in public areas with energy-saving LED lights.
  - Promote video conferencing to save transportation energy consumption from commuting personnel.
  - Install shades in sunlit areas to reduce solar radiation heat.
  - Recover rainwater to water trees in the plant.
  - Properly perform garbage sorting and recycling.
  - Provision the average office air-conditioning temperature setting of not lower than 25°C.
- (4) Promote electronic processes and move toward paperless to reduce paper and toner use, thereby reducing power consumption and carbon dioxide emissions.
  - Promote electronic internal official document, signing and approval systems.
  - Continue to promote the ERP form electronic signing and approval system.
  - Set the office machines to power-saving mode and enter the power saving mode if machines are not in use for an extended period of time.

2. Here at the Company, we have set a five-year program to minimize greenhouse gas emissions, taking the 2019 electricity consumption and carbon emissions as the base period. The goal is to cut electricity consumption per unit output by 5% by 2024 compared to 2019 and to reduce annual carbon dioxide emissions equivalent (Co2e) by 10%. The company's 2019~2020 statistical results of direct emissions and indirect energy emissions include greenhouse gas, waste, and power and water consumption energy indirect emission reduction monitoring data. Refer to the description on Pages 46~47. Improvements continued to be made in 2020.
3. The company's current greenhouse gas reduction related plans undergoing implementation and planning are as follows:
  - (1) Use recycled paper for photocopying documents in the office as much as possible.
  - (2) Adjust production processes.
  - (3) Carry out energy conservation measures in the plant.
  - (4) Properly promote garbage sorting and recycling.
  - (4) Turn off lights in the office at all times, turn off lights during lunch breaks, and check all lights are turned off after work hours.
  - (6) Fresh air inlet, toilet ventilation and exhaust discharge, time-controlled management of open office and cubicle office air-conditioning to reduce cold air loss and unnecessary power consumption.
  - (7) Adoption of Alternating Lighting in the Parking Lot

## 5.5 Labor-Management Relations

- (I) Employee benefit policy, continuing education, training, and retirement system and the implementation of these systems, labor-management agreement and the protection of employee rights:
  1. Benefit policy and the state of pursuit

Since its establishment, the Company has pursued the belief of putting the employees first and viewing them as important assets of the Company. The Company also places an emphasis on the communication between employers and employees. In addition to establishing the Employee Welfare Committee in 1992, the welfare committee members establish annual plans to host various welfare get-togethers, have

monthly birthday parties and birthday cash gifts, quarterly domestic company trips, international company trips every 2 years, three gifts during three major Chinese holidays, year-end company meals, educational training sessions, club events, health inspections, labor insurance/health insurance/group insurance, recognition of senior staff, employee equity meetings, factory group lunches, a sports and games room, employee profit-sharing, wedding and funeral cash gifts, year-end bonuses, project bonuses and other welfare measures to fully take care of the Company's employees.

## 2. Continuing education, training system and implementation

Exactly in accordance with ISO education and training methods and internal control procedures, we have planned employee training programs. The training methods are divided into in-house and outsourced programs.

In the outsourced training program department, each department is advised to submit training plans and budgets at the end of each fiscal year. Employees are advised to submit training applications based on the annual programs and their own substantial needs. After completion of the training program, they submit training experience reports or opinion surveys to the Human Resources Training Unit to register for their credits to share course information or share training internally.

The in-house training programs include: 1. New recruit training. All new recruits enter the basic course training on the day they register for employment to ensure that new recruits can quickly orient themselves to the team philosophy and culture at the very beginning of joining Flytech; 2. Project training programs. This is intended to reserve cadres and middle and high-level elite cadres, with such exclusive courses so that talents of all levels can inherit the wisdom and practical operation of Flytech people, and cultivate more elites in leadership talents in the future; 3. Credit system learning. Through such credit system, Flytech sets all colleagues every year with the very fundamental training credits that must be achieved. Those colleagues accumulate credits through participating in various in-house and outsourced courses to keep a record of their own learning process and continually improve their professional skills and self-growth; 4. Monthly [Flytech knowledge +] lectures where we invite outsourced experts to share their hands-on professional experiences. The aforementioned training programs virtually help employees improve their professional skills and career planning capabilities.

The number of participants by head count and by actual hours of training in 2020 are as follows :

| By department                               | Marketing Center | R&D Center | Manufacturing Center | Management Center |
|---|------------------|------------|----------------------|-------------------|
| Actual number of participants by head count | 124              | 276        | 4,331                | 247               |
| Actual hours of training                    | 1,030            | 1,241      | 5,450                | 579               |

The Company takes care of the employees and their retirement for motivating their morale in service with the Company throughout the duration of their careers. The Company has instituted the Regulations Governing Pension for Retirement and Bereavement in accordance with the Labor Standards Act and established the Labor Pension Reserve Monitoring Committee in accordance with applicable laws. Accordingly, the Company appropriates 2% of the total salaries of the employees to a pension reserve fund in accordance with the “Regulations for the Allocation and Management of the Workers’ Retirement Reserve Funds”. The funds will be deposited in a special account at the Central Trust of China under the title of the Pension Reserve Monitoring Committee and managed by the committee. The Labor Pension Act (hereinafter referred to as the “new system”) became effective as of July 1, 2005. The years of service of the employees who are entitled to the aforementioned regulations and the employees who registered for duties since the enactment of the new system are under the defined appropriation system thereby the Company shall appropriate 6% of their salaries as pension reserve funds to the individual special accounts of the employees for deposits.

The Company's applied regulations for the Labor Pension Statutes are as follows:

- (1) Self-requested Retirement: Employees with one of the following circumstances may request retirement:
  - ① Employees that have worked for more than 15 years and have reached the age of 55.
  - ② Employees that have worked for more than 25 years.
  - ③ Employees that have worked for more than 10 years and have reached the age of 60.
  - ④ Other employees that have their requests approved by the Company.
- (2) Mandatory Retirement: Employees with one of the following

circumstances are forced to retire:

① Employees that are 65 years old or older.

② Demented or physically disabled employees that are unfit to work.

The age specified in the preceding paragraph ① shall be reported to the central competent authority for adjustment, but employees manning positions that are dangerous or require a strong physique cannot be forced to retire if they are less than 55 years old.

The pension fund (the “Fund”) contributed by the Company is managed and administered by the Bureau of Labor Funds of the Ministry of Labor (the Bureau of Labor Funds). According to the Regulations for Revenues, Expenditures, Safeguard and Utilization of the Labor Retirement Fund, with regard to the utilization of the Fund, minimum earnings shall be no less than the earnings attainable from two-year time deposits with interest rates offered by local banks. Foreign subsidiaries with defined benefit plans make pension contributions to pension management institutions in accordance with their respective local regulations.

As of December 31, 2019 and 2020, the Company’s labor pension fund account balance at Bank of Taiwan amounted to \$28,983 and \$25,252. Refer to the website of the Bureau of Labor Funds for information on the labor pension fund assets including the asset portfolio and yield of the fund.

#### 4. Labor-management agreement

The Company has instituted the “Regulations Governing Labor-Management Conferences” in order to provide the mechanisms for labor-management consultation. The organization of the Company is managed under Horizontalization. The managers and the employees may engage in two-way communication through routine meetings or interviews. The labor-management relation of the Company has been harmonious since its establishment and there is no labor-management dispute.

#### 5. The protection of employee rights

The responsibilities and rights of the employees have been

explicitly stated in the internal control system and management regulations of the Company. In addition, the Company has established the Employee Welfare Committee to organize welfare activities. Employees are entitled to a bonus, salary adjustment, bonus, promotion or other incentives through routine performance evaluation. The company has also set up the “human rights policy” to prevent conduct infringing upon and violating human rights. In addition to providing a reasonable and safe environment and ensuring current employees are given reasonable and dignified treatment.

- (II) The loss caused by labor-management disputes in the last 2 years to the date this report was printed, and disclose the estimated amount of loss at present and in the future, and the remedial action to be taken: None.

#### **5.6 Important contracts: None.**

#### **5.7 Licensing and certification of personnel related to financial transparency by the competent authority**

The financial, accounting, and internal auditing staff and the proxies of internal auditors have received proper professional training. The chief financial officer has been certified by the Accounting Research and Development Foundation as a professional accounting officer. Likewise, the internal auditors have been certified as CIA. The aforementioned auditors received continuing education every year as required by the competent authority.

#### **5.8 Employee Code of Conduct and Ethical Corporate Management Best Practice Principles**

The Company has instituted the “Ethical Corporate Management Best Practice Principles”, “Ethical Corporate Management Procedure and Code of Conduct”, “Ethical Code of Conduct”, “Service Regulations”, “Regulations Governing the Reward and Punishment of Personnel”, “Regulations Governance Attendance of Employees”, “Regulations Governing Performance Evaluation” and other internal control procedures as the guidelines for the employees in business integrity and performance of duties, including: rules for work hours, rules for relevant grades and levels of the corporate hierarchy, rules for attendance and taking leave, prohibition of taking part-time jobs, confidentiality of business and business secrets, rules for business trips, environmental protection and responsibility of custody of company assets, rules for sharing resources and equipment, the use of information systems and network facilities, observation of internal control regulations, and routine evaluation.

The Company has posted related rules and regulations and the internal control

system on the intranet of the Company for the viewing of the employees. In addition, the Company also holds OJT training for the employees and orientation of the new employees. Through annual evaluation of the old employees and new employees, the Company makes sure that the employees understand and observes related rules and regulations.

## **5.9 Procedure for handling internal information in materiality**

The Company has instituted the “Procedure for Handling Internal Information in Materiality”, which is applicable to the Directors, Supervisors, Managers, and employees. Further to the requirements of consolidation, countersignature, review, and function for announcement of materiality and related operation procedures as set forth in related rules and regulations, the Company also tightened the procedure for confidentiality of materiality and established the “Designated Team for Handling Internal Materiality”, responses to exclusions, routine education and related management to ensure the information publicized by the Company have been approved in due procedure and in compliance with applicable laws.

## **5.10 Work environment and the protection of labor safety**

- (I) The Company conducts routine maintenance and inspection on all machines and equipment in accordance with the ISO 9001 quality management system to ensure normal running and avoid possible occupational accident.
- (II) The Company monitors and manages the quality of the environment, air, and water in accordance with ISO 14001 environmental management system to maintain positive work environment.
- (III) On the grounds of the ISO 45001 occupational safety and health management system, the Company control measures to minimize the risk of potential occupational injuries and occupational diseases toward employees to create a “safe, environmentally friendly and sustainable” friendly workplace to our entire staff.
- (IV) Here at our Company, the entire office zones and manufacturing plants are not classified into high-risk at all. Our Company has carried out regular maintenance and testing of machines and equipment accurately in accordance with the ISO 9001 quality management system to maintain their sound operation and avoid potential industrial safety accidents. Further, in compliance with ISO 14001 environmental management system and ISO 45001 occupational safety and health management system, we accurately monitor and manage the quality of the environment, air, water, and the like. The Company has also set up an “environmental safety and health committee (consolidated into ISO 14001 and 45001, upgraded” Labor Safety and Health Committee”). On a regular basis, we conduct relevant educational & training programs on safety and health, fire drills, emergency response, and the like, and take necessary preventive measures to assure being free of an occupational disaster, thereby minimizing the risk factors of

the working environment to safeguard workers in their health and safety to establish and implement, maintain and continuously improve the environmental and occupational safety and health management system.

The implementation of other specific measures pertaining to the work environment and employee safety is as follows:

1. Take labor insurance, health insurance, and group insurance for the protection of the employees.
2. Ensure safe workplace environments and provide qualified operating equipment in accordance with the Labor Facilities Safety Regulations.
3. Have regular quarterly inspections and maintenances of fire-fighting facilities (fire extinguishers, fire prevention refuge facilities, emergency lights, electrical appliances, fire pumps and fire hydrants), annual inspections and maintenances of smoke ventilation equipment, employee safety educational training sessions and disaster prevention drills every 6 months
4. Conduct daily / weekly / month / quarterly maintenance for various types of manufacturing equipment according to the ISO's "Equipment Maintenance Procedures."
5. Appoint professional technicians to inspect electrical equipment monthly.
6. Daily patrols by the Company's security personnel.
7. Routine health examination for the employees every two years.
8. Maintenances, replacement of filters, and water quality inspections for the company drinking-water equipment every 3 months.
9. Providing nutritious and healthy group lunch services for employees of the Linkou factory



## VI. Financial summary

### 6.1 Condensed balance sheet, comprehensive income statement, name of the CPAs, and their auditing opinions within the last five years

(I) Condensed balance sheet and consolidated income statement

1. The condensed and consolidated balance sheet for the last 5 years - consolidated

Unit: NTD thousand

| Year                           |                              | Financial information for the latest 5 years (Note 1) |           |           |           |                      | 2021 to end of Q1 (Note 2) |
|--------------------------------|------------------------------|---|-----------|-----------|-----------|----------------------|----------------------------|
|                                |                              | 2016  | 2017      | 2018      | 2019      | 2020                 |                            |
| Current assets                 |                              | 4,378,175   | 4,182,710 | 4,066,365 | 4,112,065 | 3,971,272            | —                          |
| Property, plant, and equipment |                              | 1,145,713   | 1,207,027 | 1,167,147 | 1,141,842 | 1,109,754            | —                          |
| Intangible assets              |                              | 587,900   | 535,467   | 438,285   | 350,067   | 301,028              | —                          |
| Other assets                   |                              | 62,004  | 83,358    | 7,335     | 4,363     | 3,841                | —                          |
| Total assets                   |                              | 6,201,367   | 6,050,863 | 5,806,721 | 5,749,792 | 5,592,068            | —                          |
| Current liabilities            | Before dividend distribution | 1,213,092   | 1,382,274 | 1,013,545 | 914,617   | 850,452              | —                          |
|                                | After Distribution           | 1,944,934   | 2,026,054 | 1,657,325 | 1,629,928 | Not yet appropriated | —                          |
| Non-current liabilities        |                              | 134,604   | 114,179   | 109,393   | 136,812   | 132,581              | —                          |
| Total liabilities              | Before dividend distribution | 1,347,696   | 1,496,453 | 1,122,938 | 1,051,429 | 983,033              | —                          |
|                                | After Distribution           | 2,079,538   | 2,140,233 | 1,766,718 | 1,766,740 | Not yet appropriated | —                          |
| Equity of the parent company   |                              | 4,529,103   | 4,235,807 | 4,391,203 | 4,403,356 | 4,334,170            | —                          |
| Capital stock                  |                              | 1,463,683   | 1,463,683 | 1,430,623 | 1,430,623 | 1,430,623            | —                          |
| Capital surplus                |                              | 761,822   | 762,804   | 745,778   | 674,247   | 597,122              | —                          |
| Retained earnings              | Before dividend distribution | 2,325,968   | 2,332,494 | 2,255,146 | 2,347,888 | 2,364,364            | —                          |
|                                | After Distribution           | 1,594,126   | 1,688,714 | 1,611,366 | 1,632,577 | Not yet appropriated | —                          |
| Other equity                   |                              | (22,370)  | (37,221)  | (40,344)  | (49,402)  | (57,939)             | —                          |
| Treasury stock                 |                              | —   | (285,953) | —         | —         | —                    | —                          |
| Non-controlling interest       |                              | 324,568   | 318,603   | 292,580   | 295,007   | 274,865              | —                          |
| Total equity                   | Before dividend distribution | 4,853,671   | 4,554,410 | 4,683,783 | 4,698,363 | 4,609,035            | —                          |
|                                | After Distribution           | 4,121,829   | 3,910,630 | 4,040,003 | 4,126,114 | Not yet appropriated | —                          |

Note 1: The 5-year financial information has been checked by an accountant.

Note 2: As of April 30 2021, audited financial information covering 2021 Q1 was still unavailable.

2. The condensed and consolidated income statement for the last 5 years -  
International Financial Reporting Standards

Unit: NTD thousand

| Item \ Year   | Financial information for the latest 5 years (Note 1) |           |           |           |           | 2021 to end of Q1 (Note 2) |
|---|---|-----------|-----------|-----------|-----------|----------------------------|
|   | 2016  | 2017      | 2018      | 2019      | 2020      |                            |
| Operating revenue   | 5,633,782   | 6,565,317 | 6,569,769 | 5,330,472 | 4,432,961 | —                          |
| Gross profit  | 1,893,789   | 1,944,203 | 1,926,378 | 1,869,256 | 1,543,506 | —                          |
| Operating gains and losses  | 982,369   | 934,178   | 906,424   | 909,977   | 701,392   | —                          |
| Non-operating revenues and expenses                                     | 21,111  | (102,424) | 13,461    | (27,473)  | 38,570    | —                          |
| Net profit before taxation  | 1,003,480   | 831,754   | 919,885   | 882,504   | 739,962   | —                          |
| Current year profit of continuing business units                        | 871,847   | 731,420   | 792,493   | 722,285   | 597,928   | —                          |
| gain(loss) from discontinued operations                                 | —   | —         | —         | —         | —         | —                          |
| Net income or loss for current period                                   | 871,847   | 731,420   | 792,493   | 722,285   | 597,928   | —                          |
| Current period other comprehensive income (post-tax profit or loss)     | (39,251)  | (13,422)  | (3,081)   | (11,059)  | (8,978)   | —                          |
| Current period other comprehensive income (Gross)                       | 832,596   | 717,998   | 789,412   | 711,226   | 588,950   | —                          |
| Net profit attributable to parent company                               | 881,816   | 738,368   | 801,448   | 736,522   | 589,644   | —                          |
| Net profit attributable to non-controlling interest                     | (9,969)   | (6,948)   | (8,955)   | (14,237)  | 8,284     | —                          |
| Total comprehensive income attributable to owners of the parent company | 843,471   | 723,517   | 798,325   | 727,464   | 581,107   | —                          |
| Comprehensive income, gross, attributable to non-controlling interest   | (10,875)  | (5,519)   | (8,913)   | (16,238)  | 7,843     | —                          |
| Earnings per share (ex-right)   | 6.02  | 5.06      | 5.60      | 5.15      | 4.12      | —                          |

Note 1: The 5-year financial information has been checked by an accountant.

Note 2: As of April 30 2021, audited financial information covering 2021 Q1 was still unavailable.

## 3. The condensed individual balance sheet for the last 5 years - individual

Unit: NTD thousand

| Year                           |                              | Financial information from the past five years (note) |           |           |           |                      |
|--------------------------------|------------------------------|---|-----------|-----------|-----------|----------------------|
|                                |                              | 2016  | 2017      | 2018      | 2019      | 2020                 |
| Item                           |                              |   |           |           |           |                      |
| Current assets                 |                              | 3,237,330   | 2,834,223 | 2,931,119 | 2,843,326 | 2,827,382            |
| Property, plant, and equipment |                              | 1,081,495   | 1,151,134 | 1,108,620 | 1,082,594 | 1,048,708            |
| Intangible assets              |                              | 8,534   | 6,265     | 3,837     | 3,434     | 1,273                |
| Other assets                   |                              | 10,614  | 4,849     | 2,968     | 552       | 448                  |
| Total assets                   |                              | 5,532,203   | 5,153,895 | 5,196,354 | 5,077,694 | 4,992,260            |
| Current liabilities            | Before dividend distribution | 918,643   | 868,746   | 751,529   | 618,835   | 605,417              |
|                                | After Distribution           | 1,650,485   | 1,512,526 | 1,395,309 | 1,334,147 | Not yet appropriated |
| Non-current liabilities        |                              | 84,457  | 49,342    | 53,622    | 55,503    | 52,673               |
| Total liabilities              | Before dividend distribution | 1,003,100   | 918,088   | 805,151   | 674,338   | 658,090              |
|                                | After Distribution           | 1,734,942   | 1,561,868 | 1,448,931 | 1,389,650 | Not yet appropriated |
| Capital stock                  |                              | 1,463,683   | 1,463,683 | 1,430,623 | 1,430,623 | 1,430,623            |
| Capital surplus                |                              | 761,822   | 762,804   | 745,778   | 674,247   | 597,122              |
| Retained earnings              | Before dividend distribution | 2,325,968   | 2,332,494 | 2,255,146 | 2,347,888 | 2,364,364            |
|                                | After Distribution           | 1,594,126   | 1,688,714 | 1,611,366 | 1,632,576 | Not yet appropriated |
| Other equity                   |                              | (22,370)  | (37,221)  | (40,344)  | (49,402)  | (57,939)             |
| Treasury stock                 |                              | —   | (285,953) | —         | —         | —                    |
| Total equity                   | Before dividend distribution | 4,529,103   | 4,235,807 | 4,391,203 | 4,403,356 | 4,334,170            |
|                                | After Distribution           | 3,797,261   | 3,592,027 | 3,747,423 | 3,688,044 | Not yet appropriated |

Note: The 5-year financial information is examined and audited by an accountant

## 4. The condensed individual composite income statement for the last 5 years - individual

Unit: NTD thousand

| Item \ Year   | Financial information from the past five years (note) |           |           |           |           |
|---|---|-----------|-----------|-----------|-----------|
|   | 2016  | 2017      | 2018      | 2019      | 2020      |
| Operating revenue   | 4,536,778   | 4,580,890 | 4,628,305 | 3,926,733 | 3,278,733 |
| Gross profit  | 1,548,750   | 1,387,265 | 1,388,268 | 1,364,656 | 1,131,575 |
| Operating gains and losses  | 1,068,316   | 935,507   | 919,636   | 916,709   | 725,868   |
| Non-operating revenues and expenses                                 | (64,577)  | (105,809) | 10,259    | (33,613)  | 31        |
| Net profit before taxation  | 1,003,739   | 829,698   | 929,895   | 883,096   | 725,899   |
| Current year profit of continuing business units                    | 881,816   | 738,368   | 801,448   | 736,522   | 589,644   |
| gain(loss) from discontinued operations                             | —   | —         | —         | —         | —         |
| Net income or loss for current period                               | 881,816   | 738,368   | 801,448   | 736,522   | 589,644   |
| Current period other comprehensive income (post-tax profit or loss) | (38,345)  | (14,851)  | (3,123)   | (9,058)   | (8,537)   |
| Current period other comprehensive income (Gross)                   | 843,471   | 723,517   | 798,325   | 727,464   | 581,107   |
| Earnings per share (ex-right)                                       | 6.02  | 5.06      | 5.60      | 5.15      | 4.12      |

Note: The 5-year financial information is examined and audited by an accountant

(II) Names of financial statement auditors in the last 5 years, and their audit opinions:

| Year | Name of CPA Firm | Name of CPAs                    | Auditor/s opinion   |
|------|------------------|---------------------------------|---------------------|
| 2016 | KPMG             | Huei-Chen Chang, Wei Ming Shih, | Unqualified opinion |
| 2017 | KPMG             | Huei-Chen Chang, Wei Ming Shih, | Unqualified opinion |
| 2018 | KPMG             | Wei Ming Shih, Yung-Sheng Wang  | Unqualified opinion |
| 2019 | KPMG             | Wei Ming Shih, Yung-Sheng Wang  | Unqualified opinion |
| 2020 | KPMG             | Wei Ming Shih, Yung-Sheng Wang  | Unqualified opinion |

## 6.2 Financial analysis for the latest 5 years

## (I) Financial Analysis - consolidated

| Analysis items (Note 2) |   | Year   |        |        |        |        | 2021 to end of Q1 (Note 2) |
|-------------------------|---|--|--------|--------|--------|--------|----------------------------|
|                         |   | Financial analysis for the latest 5 years (Note 1) |        |        |        |        |                            |
|                         |   | 2016   | 2017   | 2018   | 2019   | 2020   |                            |
| Financial structure (%) | Debt to assets ratio  | 21.73  | 24.73  | 19.34  | 18.29  | 17.58  | —                          |
|                         | Ratio of long-term capital to property, plant and equipment | 435.39   | 386.78 | 410.67 | 423.45 | 427.27 | —                          |
| Solvency (%)            | Current ratio   | 360.91   | 302.60 | 401.20 | 449.59 | 466.96 | —                          |
|                         | Liquid ratio  | 290.09   | 237.85 | 316.07 | 367.01 | 381.28 | —                          |
|                         | Interest coverage ratio                                     | 685.5  | 216.54 | 280.18 | 311.85 | 335.98 | —                          |
| Operating ability       | Account receivable turnover (times)                         | 5.12   | 5.22   | 5.96   | 6.38   | 6.16   | —                          |
|                         | Days sales in account receivable                            | 71.33  | 69.98  | 61.20  | 57.17  | 59.26  | —                          |
|                         | Inventory turnover (times)                                  | 5.03   | 5.55   | 5.58   | 4.53   | 4.23   | —                          |
|                         | Account payable turnover (times)                            | 5.81   | 6.18   | 6.95   | 7.22   | 8.77   | —                          |
|                         | Average days in sales                                       | 72.61  | 65.74  | 65.39  | 80.59  | 86.35  | —                          |
|                         | Property, plant, and equipment turnover (times)             | 4.92   | 5.44   | 5.63   | 4.67   | 3.99   | —                          |
|                         | Total assets turnover (times)                               | 0.91   | 1.09   | 1.13   | 0.93   | 0.79   | —                          |
| Profitability           | ROA (%)   | 14.34  | 11.99  | 13.41  | 12.54  | 10.57  | —                          |
|                         | Return on equity (%)  | 17.89  | 15.55  | 17.16  | 15.40  | 12.85  | —                          |
|                         | Pre-tax profits to paid-up capital ratio (%)                | 68.56  | 56.83  | 62.85  | 61.69  | 51.72  | —                          |
|                         | Net profit rate (%)   | 15.48  | 11.14  | 12.06  | 13.55  | 13.49  | —                          |
|                         | After the earnings per share (yuan) is traced back          | 6.02   | 5.06   | 5.60   | 5.15   | 4.12   | —                          |
| Cash flows              | Cash flow ratio (%)   | 97.96  | 50.93  | 132.48 | 92.35  | 122.09 | —                          |
|                         | Cash flow adequacy ratio (%)                                | 122.12   | 111.68 | 118.81 | 118.43 | 123.86 | —                          |
|                         | Cash flow reinvestment ratio (%)                            | 6.16   | -0.58  | 13.96  | 2.48   | 7.60   | —                          |
| Leverage                | Operating leverage  | 1.18   | 1.20   | 1.21   | 1.23   | 1.24   | —                          |
|                         | Financial leverage  | 1.00   | 1.00   | 1.00   | 1.00   | 1.00   | —                          |

Note 1: The 5-year financial information has been checked by an accountant.

Note 2: As of April 30 2021 audited financial information covering 2021 Q1 was still unavailable.

Note 3: The formula for the table above is as follows

## 1. Financial structure

(1) Liabilities to total assets = Total liabilities / total assets.

- (2) Ratio of long-term capital to property, plant and equipment=(Total equities+noncurrent liabilities) /property, plant and equipment
2. Solvency
- (1) Current ratio = current assets / current liabilities.
- (2) Quick ratio=(current assets-inventories-prepaid expense) /current liabilities
- (3) Interest coverage ratio = net profit before interest and tax / interest expenses for the current period.
3. Operating ability
- (1) Turnover of receivables (including accounts receivable and notes receivable due to business)  
= Net sales / balance of average receivables for each period (including accounts receivable and notes receivable due to business).
- (2) Days sales in account receivable = 365 / Account receivable turnover (times)
- (3) Inventory turnover (times) = Cost of goods sold / average inventory amount
- (4) Turnover rate of payables (including accounts payable and notes payable due to business).  
= Cost of Sales / average of payables for each period (including accounts payable and notes payable due to business).
- (5) Average days in sales = 365 / Inventory turnover (times)
- (6) Property, plant, and equipment turnover (times) = Net sales / Net average property, plant, and equipment
- (7) T Total assets turnover (times) = Net sales / Average total assets
4. Profitability
- (1) Return on assets = (after tax net profit + interest expenses x (1- tax rate)) / average asset balance.
- (2) Return on shareholders' equity = after tax net profit/ total average equity.
- (3) Profit ratio=net income/net sales
- (4) Earnings per share=(profits or loss attributable to owners of the parent company-preferred stock dividend) /weighted average stock shares issued
5. Cash flow
- (1) Cash flow ratio = net cash flow from operating activities / current liabilities.
- (2) Cash flow adequacy ratio=net cash flow from operating activities within five years / (capital expenditure+inventory increase +cash dividend) within five years
- (3) Cash re-investment ratio = (net cash flow from operating activity-cash dividend) /(gross property , plant, and equipment + long-term investment + other noncurrent assets + working capital)
6. Leverage
- (1) Operating leverage = (Net operating income - Changes in operating cost and expense) / Operating profit
- (2) Financial leverage = Operating profit / (Operating profit - interest expense)

## (II) Financial Analysis - individual

| Analysis items (Note 2) |   | Financial analysis for the latest 5 years (Note 1) |           |           |           |           |
|-------------------------|---|--|-----------|-----------|-----------|-----------|
|                         |   | 2016   | 2017      | 2018      | 2019      | 2020      |
| Financial structure (%) | Debt to assets ratio  | 18.13  | 17.81     | 15.49     | 13.28     | 13.18     |
|                         | Ratio of long-term capital to property, plant and equipment | 426.59   | 372.25    | 400.93    | 411.87    | 418.31    |
| Solvency (%)            | Current ratio   | 352.43   | 326.24    | 390.02    | 459.46    | 467.01    |
|                         | Liquid ratio  | 295.74   | 269.38    | 324.61    | 396.42    | 401.55    |
|                         | Interest coverage ratio                                     | 20,912.23  | 12,572.18 | 92,990.50 | 29,437.53 | 20,740.97 |
| Operating ability       | Account receivable turnover (times)                         | 4.72   | 4.66      | 5.25      | 5.49      | 5.20      |
|                         | Days sales in account receivable                            | 77.41  | 78.34     | 69.49     | 66.54     | 70.15     |
|                         | Inventory turnover (times)                                  | 5.97   | 6.63      | 6.87      | 6.08      | 5.66      |
|                         | Account payable turnover (times)                            | 5.44   | 5.74      | 6.80      | 7.23      | 8.74      |
|                         | Average days in sales                                       | 61.13  | 55.05     | 53.11     | 60.07     | 64.54     |
|                         | Property, plant, and equipment turnover (times)             | 4.19   | 3.98      | 4.17      | 3.63      | 3.13      |
|                         | Total assets turnover (times)                               | 0.82   | 0.89      | 0.89      | 0.77      | 0.66      |
| Profitability           | ROA (%)   | 15.96  | 13.82     | 15.49     | 14.34     | 11.71     |
|                         | Return on equity (%)  | 19.41  | 16.85     | 18.58     | 16.75     | 13.50     |
|                         | Pre-tax profits to paid-up capital ratio (%)                | 68.58  | 56.69     | 65.00     | 61.73     | 50.74     |
|                         | Net profit rate (%)   | 19.44  | 16.12     | 17.32     | 18.76     | 17.98     |
|                         | After the earnings per share (yuan) is traced back          | 6.02   | 5.06      | 5.60      | 5.15      | 4.12      |
| Cash flows              | Cash flow ratio (%)   | 115.95   | 82.92     | 143.99    | 138.46    | 124.04    |
|                         | Cash flow adequacy ratio (%)                                | 125.83   | 107.72    | 109.60    | 112.26    | 111.98    |
|                         | Cash flow reinvestment ratio (%)                            | 5.41   | -0.23     | 8.62      | 2.74      | 2.07      |
| Leverage                | Operating leverage  | 1.09   | 1.09      | 1.1       | 1.09      | 1.10      |
|                         | Financial leverage  | 1.00   | 1.00      | 1.0       | 1.00      | 1.00      |

Note 1: All financial information for the 5 years has been audited

Note 2: The formula for the table above is as follows

1. Financial structure

(1) Liabilities to total assets = Total liabilities / total assets.

(2) Ratio of long-term capital to property, plant and equipment = (Total equities + noncurrent liabilities) / property, plant and equipment

2. Solvency

Current ratio = current assets / current liabilities.



- (2) Quick ratio=(current assets-inventories-prepaid expense) /current liabilities
- (3) Interest coverage ratio = net profit before interest and tax / interest expenses for the current period.
3. Operating ability
- (1) Turnover of receivables (including accounts receivable and notes receivable due to business)  
= Net sales / balance of average receivables for each period (including accounts receivable and notes receivable due to business).
- (2) Days sales in account receivable = 365 / Account receivable turnover (times)
- (3) Inventory turnover (times) = Cost of goods sold / average inventory amount
- (4) Turnover rate of payables (including accounts payable and notes payable due to business).  
= Cost of Sales / average of payables for each period (including accounts payable and notes payable due to business).
- (5) Average days in sales = 365 / Inventory turnover (times)
- (6) Property, plant, and equipment turnover (times) = Net sales / Net average property, plant, and equipment
- (7) T Total assets turnover (times) = Net sales / Average total assets
4. Profitability
- (1) Return on assets = (after tax net profit + interest expenses x (1- tax rate)) / average asset balance.
- (2) Return on shareholders' equity = after tax net profit/ total average equity.
- (3) Profit ratio=net income/net sales
- (4) Earnings per share=(profits or loss attributable to owners of the parent company-preferred stock dividend) /weighted average stock shares issued
5. Cash flow
- (1) Cash flow ratio = net cash flow from operating activities / current liabilities.
- (2) Cash flow adequacy ratio=net cash flow from operating activities within five years / (capital expenditure+inventory increase +cash dividend) within five years
- (3) Cash re-investment ratio = (net cash flow from operating activity-cash dividend) /(gross property , plant, and equipment + long-term investment + other noncurrent assets + working capital)
6. Leverage
- (1) Operating leverage = (Net operating income - Changes in operating cost and expense) / Operating profit
- (2) Financial leverage = Operating profit / (Operating profit - interest expense)

- 6.3 Audit report on the most recent year financial statements by the supervisor or the audit committee:** please refer to page 146
- 6.4 The most recent annual financial report:** please refer to pages 147-209
- 6.5 The Company's individual financial statements audited and certified by a certified public accountant in the most recent fiscal year.** Please refer to page 210-271.
- 6.6 If the company or its affiliated enterprises have experienced financial difficulties during the most recent fiscal year or the current fiscal year up to the date of printing of annual report, the annual report shall explain how said difficulties will affect the company's financial status:** None.

## VII. Review of financial status, business performance, and risk management issues

### 7.1 Financial status

Unit: NTD thousand

| Item                              | Year | 2019             | 2020             | Variation                        |                |
|-----------------------------------|------|------------------|------------------|----------------------------------|----------------|
|                                   |      |                  |                  | Increase (decrease)<br>in amount | %              |
| Current assets                    |      | 4,112,065        | 3,971,272        | (140,790)                        | ( 3.42)        |
| Non-Current assets                |      | 1,637,727        | 1,620,796        | (16,931)                         | ( 1.03)        |
| <b>Total assets</b>               |      | <b>5,749,792</b> | <b>5,592,068</b> | <b>(157,724)</b>                 | <b>( 2.74)</b> |
| Current liabilities               |      | 914,617          | 850,452          | (64,165)                         | ( 7.02)        |
| Non-current liabilities           |      | 136,812          | 132,581          | (4,231)                          | ( 3.09)        |
| <b>Total liabilities</b>          |      | <b>1,051,429</b> | <b>983,033</b>   | <b>(68,396)</b>                  | <b>( 6.51)</b> |
| Capital stock                     |      | 1,430,623        | 1,430,623        | 0                                | -              |
| Capital surplus                   |      | 674,247          | 597,122          | (77,125)                         | (11.44)        |
| Retained earnings                 |      | 2,347,888        | 2,364,364        | 16,476                           | 0.70           |
| <b>Total shareholders' equity</b> |      | <b>4,698,363</b> | <b>4,609,035</b> | <b>(89,328)</b>                  | <b>( 1.90)</b> |

- (I) The ratio of the changes between the early and later stages more than 20%, and the analysis of changes for amounts exceeding NTD 10 million is as follows:  
None.
- (II) Impact of changes in financial situation: There is no significant impact to the financial situation.
- (III) The future response plan: Not applicable.

## 7.2 Financial Performance

## (I) Comparative analysis of operating results

Unit: NTD thousand

| Item                                | Year | 2019        | 2020        | Increase<br>(decrease) | Variation<br>(%) |
|-------------------------------------|------|-------------|-------------|------------------------|------------------|
|                                     |      | Total       | Total       |                        |                  |
| Operating revenue - net             |      | 5,330,472   | 4,432,961   | (897,511)              | ( 16.84)         |
| Operating cost                      |      | (3,461,216) | (2,889,455) | 571,761                | ( 16.52)         |
| Gross profit                        |      | 1,869,256   | 1,543,506   | (325,750)              | ( 17.43)         |
| Operating expenses                  |      | (959,279)   | (842,114)   | 117,165                | ( 12.21)         |
| Operating profit                    |      | 909,977     | 701,392     | (208,585)              | ( 22.92)         |
| Non-operating revenues and expenses |      | (27,473)    | 38,570      | 66,043                 | ( 240.39)        |
| Net profit before taxation          |      | 882,504     | 739,962     | (142,542)              | ( 16.15)         |
| Income tax expenses                 |      | (160,219)   | (142,034)   | 18,185                 | ( 11.35)         |
| Net income                          |      | \$ 722,285  | \$ 597,928  | \$ (124,357)           | ( 17.22)         |

Analysis of changes with ratios of more than 20% between the early and later stages are as follows:

1. The decrease in operating profit, due primarily to the decrease in sales and management expenses.
2. The increase in non-operating income and expenditure was due primarily to the increase in government subsidy income from the COVID-19 pandemic and the decrease in exchange losses incurred by foreign currency conversion, resulting in net non-operating income in 2020 and net non-operating expenditure in 2019.

## (II) Analysis of changes in gross profit:

Unit: NTD thousand

|              | Number of increases and decreases from early to later periods | The root cause of the difference |                     |                    |                   |
|--------------|---|----------------------------------|---------------------|--------------------|-------------------|
|              |   | Price differentiation            | Cost price variance | Sales-mix variance | Quantity variance |
| Gross profit | (325,750)   | (113,793)                        | 54,079              | (31,473)           | (234,563)         |
| Remark       |   | Note 1                           | Note 2              | Note 3             | Note 4            |

Note 1: Develop regional markets based on different market characteristics. The fluctuation of product prices result in unfavorable price differentiations.

Note 2: Due to good control control of material costs and the effective reduction of modular design costs, there was a favorable cost price difference.

Note 3: The difference between the two terms caused by the product sales ratio resulted in a detrimental difference in sales portfolio.

Note 4: The company is committed to the promotion of various product series, resulting in differences in quantity and giving rise to detrimental quantity differences.

### 7.3 Cash flow

#### (I) Cash flow analysis in the most recent year

Unit: NTD thousand

| Beginning of year cash balance<br>(1) | Expected net operating cash flow for the whole year<br>(2) | Net annual cash outflow<br>(3) | Cash surplus (deficit)<br>(1)+(2)-(3) | Remediation measures against expected cash flow deficit |                   |
|---------------------------------------|--|--------------------------------|---------------------------------------|---|-------------------|
|                                       |  |                                |                                       | Investment plans  | Wealth management |
| 2,210,850                             | 1,038,321  | 709,092                        | 2,540,079                             | -   | -                 |

#### 1. Changes of cash flow in current year analysis:

(1) Operating Activities: The net cash flow from operating activities was NT\$ 1,038,321 thousand, which was mainly composed of cash flow from the net profit generated from 2020 operating activities.

(2) Investment activities: The net cash inflow from investment activities came to NT\$4,409 thousand, due primarily to the increase in financial asset inflows and other financial assets measured by the amortized cost of the disposal this year.

(3) Financing Activities: The net cash flow from financing activities was NT\$ 707,026 thousand, which was composed from shareholders' cash dividends.

#### 2. Responsive measures and liquidity analysis on cash flow deficits:

No cash shortages are expected.

#### (II) Liquidity analysis for the next year

The company does not need to provide financial forecasts for the coming year, including cash flow forecasts.

### 7.4 Material capital expenditures in the latest year and impacts on business performance

(I) The implementation of major capital expenditures and the sources of funds:  
Not applicable.

(II) Expected effects: Not applicable

### 7.5 The major causes for profits or losses incurred by investments during the most recent year; rectifications and investment plans for the next year

Unit: NTD thousand

| Item                                 | Remark | Re-investment policy  | Invested Company's 2020 profit and loss | Main causes of profit or loss                   | Improvement Plan      | Other future Investment plans |
|--------------------------------------|--------|---|---|---|-----------------------|-------------------------------|
| box Holdings                         |        | Achieve vertical integration synergy                                  | 9,406                                   | Strategic success and operational growth        |                       | —                             |
| Flytech USA                          |        | Expanding the American market and customer services                   | (224)                                   | Customer service base fee Center                |                       | —                             |
| Flytech HK                           |        | Expanding the Asian market and customer services                      | 5,249                                   | Strategic success and operational growth        |                       | —                             |
| Flytech Shanghai                     |        | Expand the market of Mainland China, production and customer services | 7,800                                   | Strategic success and operational growth        |                       | —                             |
| QIJIE Electronics (Senzhen) Co., Ltd |        | Expand the market of Mainland China, production and customer services | (2,772)                                 | New startup company                             | Enhance marketing     | —                             |
| iSAPPOS Systems                      |        | Horizontal integration including large product lines                  | (36)                                    |   |                       | —                             |
| iRuggy Systems                       |        | Horizontal integration including large product lines                  | 167                                     |   |                       | —                             |
| Berry AI                             |        | Achieve vertical integration synergy                                  | (27,245)                                | New startup company                             | Break-even in 2 years | —                             |
| Poindus system                       |        | Horizontal integration including large product lines                  | 37,518                                  | Strategic success Continuous operational growth |                       | —                             |
| Poindus UK                           |        | Horizontal integration including large product lines                  | (3,735)                                 | Fierce market competition                       | Enhance marketing     | —                             |
| Poindus GE                           |        | Horizontal integration including large product lines                  | (95)                                    |   |                       | —                             |
| Adasys GmbH                          |        | Horizontal integration to expand product line                         | 2,537                                   | Strategic success and operational growth        |                       | —                             |
| box UK                               |        | Achieve vertical integration synergy                                  | 9,795                                   | Strategic success and operational growth        |                       | —                             |
| box Nordic                           |        | Achieve vertical integration synergy                                  | 729                                     |   |                       | —                             |

**Note 1: iSAPPOS Systems launched the liquidation process in June 2020 and completed the entire liquidation process in February 2021.**

## 7.6 Risk assessment

- (I) The impact of changes in interest rate, exchange rate, and inflation on the Company's profit or loss in recent years to the date this report was printed, and future response measures

1. The impact of interest rate changes and response measures

Interest rate risks have an impact on the Company's income, which is divided into income and capital cost. For interest income, the Company evaluates the low-risk and high-liquidity investments, and most of the remaining funds are used in bank deposits as a conservative operating procedure to minimize the impact the changes in interest rates. There are no significant changes to future financial management policies. For capital costs, there are no debt plans. Therefore, the assessment is that interest rate changes have no significant impact to the Company's income.

2. The impact of exchange rate changes and response measures

The export of Company's products takes up approximately 90% of the revenue as product prices are mainly listed in US dollars, followed by the British pound. Since some of the imported key components are mostly denominated in US dollars, the exchange rate trends of the US dollar and the British pound is closely related to Company's exchange gains and losses. The Company mainly uses natural hedging and forward exchange contracts as responses to the impact of exchange rate changes. The response measures are as follows:

- (1) Pay attention to the domestic and foreign political and economic situations to quickly grasp the pace of the foreign exchange market and make advance/delayed payment transactions depending on the trending direction of the listed currency.
- (2) Consider the exchange rate fluctuation factors to ensure reasonable Company profits and costs providing clients with a quotation and negotiating purchase conditions.
- (3) Establish natural hedging for corresponding net positions holding foreign currencies, preferably use the same currency for sales quotations and purchases to reduce exchange rate risks.
- (4) Regularly estimate the net import and export demand of foreign currencies, analyze domestic and foreign trade/economic information and recommendations for corresponding banks, study the trends of the foreign exchange market, and hedge risks with forward exchange contracts based on the "Procedures for Acquisition or Disposal of Assets."

### 3. The impact of price changes and response measures

The company's material costs are directly affected by the price fluctuation of raw materials. Influenced key components and structural materials include LCD / LED Panels, Touch screens, etc., accounting for approximately 40% of the total cost. As the Company's products are manufactured to client specifications, the products are uniquely tailored to client needs. Therefore, the company is at an advantageous position when pricing products and negotiating with clients. In order to reduce the impact of price changes on the company's profit, the measures for material purchase costs are as follows:

- (1) Strengthen the "design for cost" cost control during the research and development stage, introduce modular design and converge material specifications when designing the electronics, reduce purchase costs by taking advantages of bulk purchases, and use core technology advantages to develop streamlined, sturdy and practical structural designs. The structural design can reduce size and weight, and also reduce the consumption of metal and plastic parts.
- (2) Plan long-term procurement plans or the policy buy project procurements to ensure a constant supply of raw materials and effectively control the material costs for common materials, or for original materials with expected price fluctuations/material shortages/price increases.
- (3) Analyze the cost structure of the manufacturer's quotation, assist suppliers to improve the efficiency and reduce consumption to save costs, provide forecasts to increase the visibility of procurement demands, increase manufacturers' willingness to cooperate, and increase the amount of leverage when negotiating prices.
- (4) Continue to enhance the information communication platform for production and sales procurement, accelerate the response speed of market information, and timely adjust procurement plans and sales quotations.

(II) The policy of engaging in high-risk, highly leveraged investments, loaning of funds, endorsements and guarantee, and derivatives trading, the main reason for profit or loss in recent years to the date this report was printed, and future response measures:

1. The Company adopts a steady and conservative financial management policy, and the relevant operating procedures and announcements are handled in accordance with the Company's "Procedures for Acquisition or Disposal of Assets," "Procedures of Endorsements and Guarantees"



and “Management of Loans to Others.”

2. The Company follows a steady and conservative financial management policy. In the past, the Company did not engage in high-risk and highly leveraged investment activities. The Company will continue to carefully evaluate high-risk investments and financial activities to avoid potential risks. The situation of the Company and its subsidiaries for 2020 and up until the most recent annual report are as follows:

(1) Endorsement and guarantee

Subsidiary Box Technologies Limited (a subsidiary of Box Holdings) has applied for a £2 million credit line to Chang Hwa Commercial Bank in order to expand the operating turnover requirements of the European market. The Company has evaluated this case using the “Procedures of Endorsements and Guarantees” and reported it to the board of directors for approval providing a 100% guarantee for the aforementioned credit case, which did not exceed the limit. The subsidiary has not yet used the facilities as of the annual report’s publication date. Apart from this case, all subsidiaries have not been endorsed or guaranteed by others.

(2) Loans to others

Poindus Systems has evaluated subsidiary Adasys GmbH using the “Management of Loans to Others,” and reported the case to the board of directors for approval of a loan to Adasys GmbH. The loan balance at the end of 2020 was 650,000 euros, which did not exceed the limit. Meanwhile, after Poindus System Co., Ltd. considered the fact that its subsidiary Poindus Systems UK LTD’s AR and the repayment plan for a certain period of time beyond the normal credit line at the end of July 2020, it assessed that part of the payment should not be repaid in full in a short period of time, a sum of GBP800,000 was reported to the board of directors meeting convened in August to be converted into loan fund. Except for the two aforementioned fund loan cases, the Company and other subsidiaries have not loaned funds externally.

(3) Derivative transactions

The Company's derivatives trading strategies are hedge trades that are designed to circumvent the risk of exchange rate fluctuations of existing foreign currency assets or liabilities. Subsidiaries apart from Box Technologies Ltd. (a subsidiary of Box Holdings) used forward exchange contracts for hedging in accordance with the “Procedures for Acquisition or Disposal of Assets” regulations for derivative transactions, and have made monthly announcements according to company regulations. Other subsidiaries have never engaged in

derivative transactions.

(III) Recent R&D investment plans and progress, and future R&D plans and estimated T&D investment expenses:

The Company's 2020 R&D plans were carried out according to schedule. Apart from a small number of products that have completed testing, verification and production trials for mass production during the first half of 2021, the rest have already been put into mass production and sales. Apart from completing unfinished products from the previous year, expand its product range and existing product series, the company's 2019 R&D direction will continue to develop competitive new product lines with high added value for different market segments and application areas, and actively expand emerging demand markets to innovatively develop diverse application fields. In addition, the Company controls the R&D progress using projects, and pays constant attention to the development of technology, product trends, the situation of competitors, sales markets and demand changes in the material supply market. They are all factors that can potentially affect the success of the R&D, therefore all R&D plans must meet market demands and completed on schedule.

| Year | R&D Plan   | Current progress of unfinished R&D Plans   | Expected mass production completion time       | Reinvested R&D expenses   | The main factors affecting successful R&D in the future |
|------|--|--|--|---|---|
| 2020 | 1. Industrial computer series:<br>POS615/ POS665/ POS617N/<br>POS667N/ PB96/ M276/ M278/<br>K736/ K737/ K738/ K739 /<br>K889/ PC17/PC18/ PC26<br>2. New motherboard series:<br>D98/ F12/ F14/ F16/ F63U/ F64U/<br>F93/ F93S  | Most of them have been developed in 2020, and a small number of unfinished products will be mass-produced in the first half of 2021. | Mass production according to the original plan | None  | None  |
| 2021 | 1. Industrial computer series:<br>POS317/ POS337N2/ POS457/<br>PC38/ PC39/ PC40/ PC41/<br>PC42/ PC43/ PC45/ B6140/<br>K759N, K959T/ M275/ M285/<br>PC83, PC28<br>2. New motherboard series:<br>F91/ F92S/ F93S/ F94/ F95/<br>F96/ F97/ F98/ F99S/ F31/ F32/<br>F34/ F36/ F86/ F8A/ F8B | In progress  | End of 2021                                    | It is estimated that the research and development expenses will be NTD 158,238 thousand in 2021 | None  |

- (IV) The impact of the changes in domestic and foreign major policies and law on the Company's finance and business in the most recent years to the date this report was printed, and the response measures:

The Company continues to pay attention to changes in domestic and foreign political and economic environments, important policies and laws. The company is always analyzing and reviewing the impact of these changes, and make revisions to company regulations when competent authorities issue important information on corporate governance and risk control. After assessments, the aforementioned changes up until the 2020 annual report publication date have not significantly impacted the Company's finances and businesses. Therefore, the response measures are not applicable.

- (V) The impact of the changes in technology and industry on the Company's finance and business in the most recent years to the date this report was printed, and the response measures:

Since its inception, the Company has been actively involved in the design, sales channels and R&D of computer products. Since the Company's establishment, Taiwan's electronic industry has undergone dramatic changes and various innovative technologies have been introduced in recent years, such as mobility payments, big data applications, and unmanned stores self service. The Company fully understands the pace of technology and industry trends, and has introduced new product designs to provide innovative applications. Therefore, correct product positioning with flexible sales strategies and extensive market channels allows the company to be ahead of its competitors. The Company's products are customized products tailor-made to client specifications as the Company's competitive foundation is based on flexible customization and offering products to a wide range of applicative products, and is capable of maintaining stable profits. After assessments, the changes in technology and industries up until the Company's 2020 annual income and annual report publication dates have not significantly impacted the Company's finances and businesses. Therefore, the response measures are not applicable.

- (VI) The impact of changes in corporate image on the Company's crisis management in the most recent years to the date this report was printed and the response measures:

Since inception, the company has adhered to the corporate philosophy of "pursuit of excellence, integrity, and steadiness." Focused on its trade, the company pursues "flexibility" and "innovation," attaching importance to

corporate image and risk control. In terms of organizational operations and system launch, emphasis is given to “the system of a large company and the flexibility of a small company.” Faced with changes in external environment and challenges, the company maintains a high degree of organizational flexibility to quickly respond to market changes. When disasters (including typhoons, floods, earthquakes, information system interruptions, raw material supply, epidemics, or power supply shortages, and other natural and manmade disasters) occur, emergency recovery plans, contingency plans, and task teams are set up, while periodic evaluations, corrections, and drills are conducted to ensure the company can quickly resume normal operations during occurrences of emergency events.

Besides this, in the board of directors meeting convened in January 2021, it was passed that the “Risk Management Policy and Operating Rules” should be duly enacted to set up a sound risk management framework to expressly define the division of responsibilities as follows to ensure that the business operation can continually go ahead to prevent potential losses to achieve sustainable operations purposes:

1. That the Board of Directors functions as the highest governance unit for risk management, assuming the responsibility to approve risk management policies and the ultimate responsibility for the effectiveness of risk management.
2. That the General Manager should assume the responsibility to make the approved risk management policies known, to set the Company’s overall goals, identify risk categories and risk tolerance thresholds and to supervise the permanent risk management units (Flytech related departments and subsidiaries) to establish appropriate risk management measures.
3. That the permanent risk management unit (Flytech’s relevant department) should assume the responsibility to set up departmental goals based on the overall goals to analyze the internal and external environment and the needs by the stakeholders to further identify the risks of the goals which have failed to be achieved and to, in turn, analyze the degree of impact upon establishment of appropriate management measures, including internal control systems, verification authority, important management measures, and operating procedures and the like to continually manage daily operational risks through an internal control review mechanism.
4. In case of a significant unpredictable emergency, the General Manager shall set up a special Task Force to take countermeasures as appropriate.
5. The Audit Department shall watch and oversee the risk management issues to check and make sure the effectiveness of the implementation in the management system.

In 2020 and as of the publication date of the annual report, the Company's internal control system has proved to have been appropriately managed and controlled without any significant risk oriented issues that were likely to impact the business operation taking place. In 2020, the supreme external risk was the coronavirus pandemic (COVID-19) spreading over the entire world. The sound countermeasures carried out by the Company are detailed in Point XIII.

- (VII) The expected benefits, potential risks and response measures for mergers and acquisitions for the most recent year and up to the date of publication of the annual report are as follows:

None

- (VIII) The expected benefits, potential risks and response measures for the factory expansion for the most recent year and up to the date of publication of the annual report are as follows:

The Company has no plans to expand the factory for the most recent year of 2020 and publication date of the annual report.

- (IX) The risks and corresponding measures faced with the purchase and sale of goods in the most recent year and up to the date of publication of the annual report are as follows:

1. Purchase: During 2020 and up until the publication date of the annual report, the company has not exceeded the net purchase amount of 10%, except for purchases from large-scale IC agency Synnex Technology. The purchases were not overly concentrated either.
2. Sales: The Company is a professional manufacturer of custom development and designs for industrial computers, and its main sales targets include system integrators, enterprise projects, and international companies. The types of clients are more dispersed as there are no concerns of excessive concentration.

- (X) The risks and impacts of significant shareholding transfers by directors, supervisors, or major shareholders with more than 10% ownership interest in the most recent years to the date this report was printed and the responsive measures to such risks:

In 2020 and up until the publication date of the annual report, the Company's directors, supervisors or shareholders holding more than 10% of the shares did not have large share transfers or replacements.

- (XI) The impact, risks and response measures to the changes in management rights on the company in the most recent year and up until the date of publication of the annual report are as follows:

The Company has no circumstances or plans for the transfer of management rights in 2020 and up till the publication date of the annual report.

- (XII) In the most recent year and up till the publication date of the annual report, lawsuits and non-contentious cases should clearly state the company and the company's directors, supervisors, general managers, substantive people in charge, major shareholders and subordinates with a shareholding ratio of more than 10%, major lawsuits, non-contentious cases, or major administrative disputes with determined judgements or still pending judgement. The results may have a significant impact on shareholders' equity or securities prices, and individuals should disclose the facts of the dispute, the bid amount, the commencement date of the lawsuit, main parties involved and the handling of the situation up until the publication date of the annual report:

The Company has no related lawsuits or non-contentious cases for 2020 and up until the publication date of the annual report.

- (XIII) Other significant risks and responsive measures:

The COVID-19 pandemic proved to be the worst ever external risk to the Company in 2020, virtually impacting upon the economic activities, transportation and mode of consumption behaviors throughout the world. COVID-19, as well, has tremendously disturbed the entire Company in business operation and in working mode for our staff members. For that, the Company's General Manager guided the Management Center to set up the Emergency Countermeasures Task Force as early as in the first quarter 2020 which has rendered pretty sound countermeasures as enumerated below:

- 1、In terms of business operation: Here at our Company, our research & development and business teams accelerate the progress of new product series to respond to changes in the application market. They, as well, assist customers in developing new application business opportunities to cope with the impact of market demand with customers, turning crises into a turnaround, using the increase in demand for medical resources and vigorously carrying out the development of new fields and new products. Thanks to such efforts in combination, we successfully won the business project aiming at respirator control hosts. More than ten thousand units of such hosts have been delivered and installed since late

2020. Other than contributing to the medical system, that is also a typical example of success in turning a crisis into a happy turnaround.

- 2、Internal management: In our Company, the Emergency Response Task Force implements pandemic prevention and control mechanisms including: All-out health examinations for the entire staff on a weekly basis, all-out temperature measurement of all employees and wearing masks, ventilation and disinfection of the entire working environments, minimization of home quarantine and business trips, using videoconference instead of face-to-face group meeting, the triage measurement for employees to avoid contact inside offices so as to safeguard both the entire staff and visitors as much as possible. Thanks to the exceptional efforts by the Emergency Response Task Force as well as the entire staff, Flytech successfully passed the toughest year, safe and sound.

**7.7 Other important disclosures:** None.

## VIII. Special remarks

### 8.1 Affiliated companies

(I) Affiliates consolidated business report:

#### 1. Affiliated Enterprises overview

(1) The investment relationship and shareholding ratio of the Company and its subsidiaries are as follows (data deadline: December 31<sup>st</sup>, 2020)

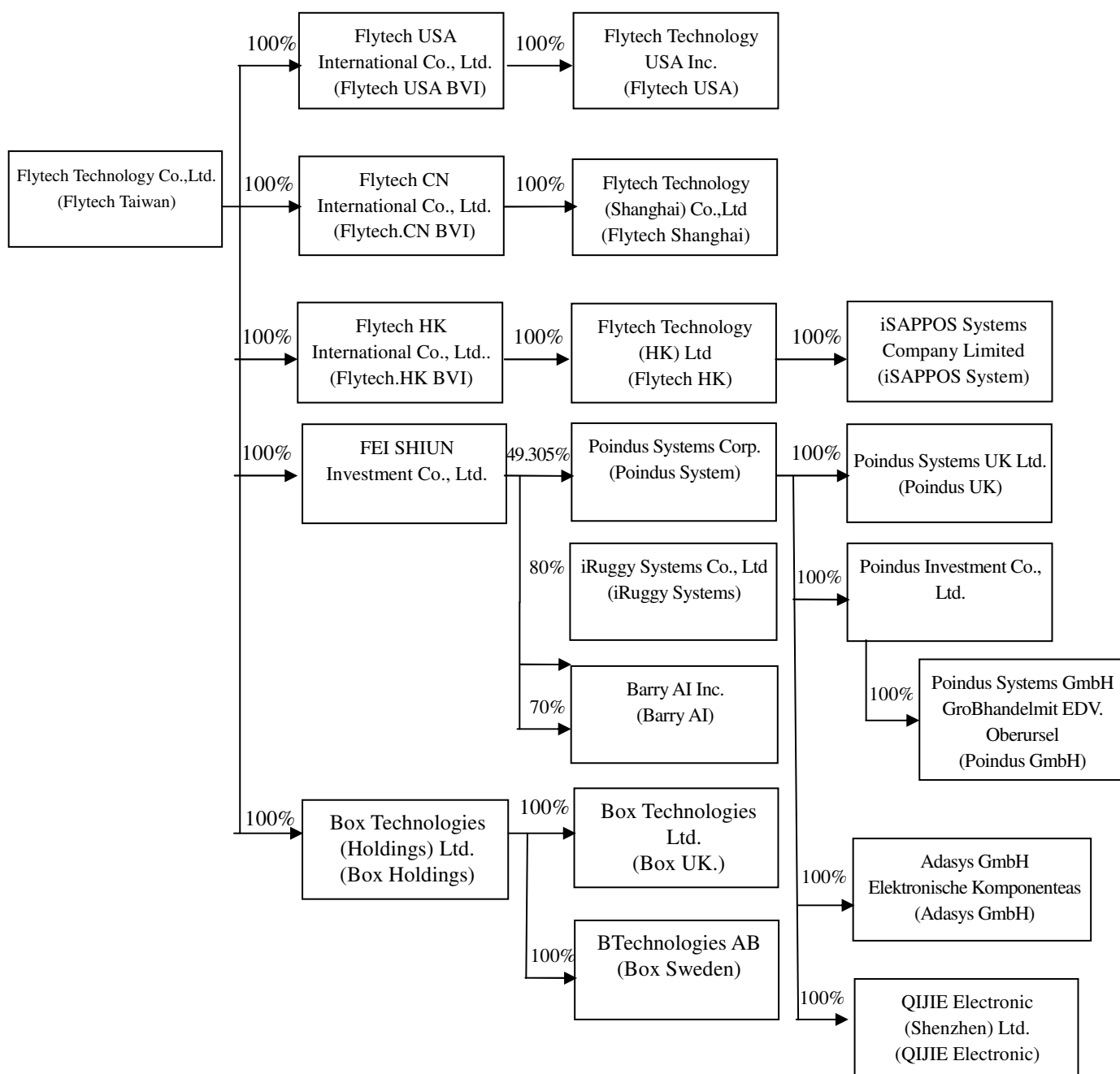



## (2) Profiles of the Affiliated Enterprises

December 31, 2020; Unit: NTD thousand

| Name of enterprise           | Date of establishment | Address        | Paid-in shares Capital | Major operations  |
|------------------------------|-----------------------|----------------|------------------------|---|
| Flytech USA BVI              | 2001.05               | Vergin islands | 3,355                  | Holdings  |
| Flytech HK BVI               | 2001.05               | Vergin islands | 1,723                  | Holdings  |
| Flytech CN BVI               | 2001.07               | Vergin islands | 6,544                  | Holdings  |
| Fei-Syun investment Co. Ltd. | 2008.01               | Taipei City    | 190,000                | General investment business   |
| Box Holdings                 | 2004.01               | United Kingdom | 189                    | General investment business   |
| Flytech USA                  | 1989.11               | U.S.           | 23,741                 | Transactions of computers, instrument systems, peripheral equipment                       |
| Flytech HK                   | 1989.12               | Hong Kong      | 10,433                 | Transactions of computers, instrument systems, peripheral equipment                       |
| Flytech Shanghai             | 2001.10               | Shanghai       | 69,089                 | Transactions of computers, instrument systems, peripheral equipment                       |
| QIJIE Electronics            | 2019.01               | Shenzhen City  | 30,850                 | Transactions of computers, instrument systems, peripheral equipment                       |
| iSAPPOS Systems (Note)       | 2015.12               | Hong Kong      | 31,690                 | Transactions of computers, instrument systems, peripheral equipment                       |
| iRuggy Systems               | 2015.12               | Taipei City    | 60,000                 | Transactions of computers, instrument systems, peripheral equipment                       |
| Berry AI                     | 2019.01               | Taipei City    | 60,000                 | Manage data software and information management, integrate software and hardware service. |
| Poindus system               | 98.06                 | Taipei City    | 210,000                | Transactions of computers, instrument systems, peripheral equipment                       |
| Poindus Investment           | 2009.07               | Taipei City    | 4,100                  | General investment business   |
| Poindus UK                   | 2015.10               | United Kingdom | 14,297                 | Transactions of computers, instrument systems, peripheral equipment                       |
| Adasys GmbH                  | 1994.03               | Germany        | 3,292                  | Transactions of computers, instrument systems, peripheral equipment                       |
| Poindus GE                   | 2015.10               | Germany        | 1,721                  | Transactions of computers, instrument systems, peripheral equipment                       |
| Box UK                       | 1992.06               | United Kingdom | 472                    | Transactions of computers, instrument systems, peripheral equipment                       |
| Box Nordic                   | 2013.08               | Sweden         | 2,330                  | Transactions of computers, instrument systems, peripheral equipment                       |

Note: iSAPPOS Systems launched the liquidation process in June 2020 and completed the entire liquidation process in February 2021.

(3) Presumed to have control and has affiliation according to Article 369-3 of the Company Act: None

(4) The industries housed in the same business location of the whole Affiliated Enterprises:

The relationship between the Company and the business operations of affiliated companies include: the electronics industry, the computer industry, the manufacturing industry, and merchandising-sector companies.

## (3) Profiles of Directors, Supervisors and Presidents of the Affiliated Enterprises:

December 31, 2020

| Name of enterprise  | Title      | Company name or representative                                      | Status of shareholding                  |  |
|---------------------|------------|---|---|--|
|                     |            |   | Number of shares or Contribution amount | Shareholding or contribution ratio (%) |
| Flytech USA BVI     | Chairman   | Flytech Technology Co., Ltd.<br>Representative: Liu Chiu Tsao       | 100,000 shares                          | 100 %                                  |
| Flytech HK BVI      | Chairman   | Flytech Technology Co., Ltd.<br>Representative: Liu Chiu Tsao       | 50,000 shares                           | 100 %                                  |
| Flytech CN BVI      | Chairman   | Flytech Technology Co., Ltd.<br>Representative: Liu Chiu Tsao       | 200,000 shares                          | 100 %                                  |
| Fei-Syun investment | Chairman   | Flytech Technology Co., Ltd.<br>Representative: Liu Chiu Tsao       | 19,000,000 shares                       | 100 %                                  |
|                     | Director   | Flytech Technology Co., Ltd.<br>Representative: Chuo Chun Hung      |   |  |
|                     | Director   | Flytech Technology Co., Ltd.<br>Representative: Liu Yun Ping        |   |  |
|                     | Supervisor | Flytech Technology Co., Ltd.<br>Representative: Lee Mei Huei        |   |  |
| box Holdings        | Director   | Liu Chiu Tsao   | —                                       | —                                      |
|                     | Director   | Lin Yi-zhi  |   |  |
|                     | Director   | Russell Willcox   |   |  |
| Flytech USA         | Chairman   | Lam Tai Seng  | —                                       | —                                      |
| Flytech HK          | Chairman   | Lam Tai Seng  | HKD 1,000,000                           | 100 %                                  |
|                     | Director   | Flytech HK BVI  |   |  |
| Flytech Shanghai    | Chairman   | Flytech CN BVI Representative:<br>Wang Wei Wei                      | USD 2,000,000                           | 100 %                                  |
|                     | Director   | Flytech CN BVI Representative:<br>Lam Tai Seng                      |   |  |
|                     | Director   | Flytech CN BVI Representative:<br>Liu Chiu Tsao                     |   |  |
|                     | Supervisor | Flytech CN BVI Representative:<br>Lee Mei Huei                      |   |  |
| QIJIE Electronics   | Director   | Wang Wei-He   | USD 1,000,000                           | 100 %                                  |
|                     | Supervisor | Chang Hong-rui  |   |  |
| iSAPPOS Systems     | Chairman   | Pan Ming-an   | HKD 7,500,000                           | 100 %                                  |
|                     | Director   | Lin Yi-zhi  |   |  |
| iRuggy Systems      | Chairman   | FEI SHIUN Investment Co., Ltd.<br>Representative:<br>Liu Chiu Tsao  | 6,000,000 shares                        | 100 %                                  |
|                     | Director   | FEI SHIUN Investment Co., Ltd.<br>Representative:<br>Chuo Chun Hung |   |  |
|                     | Director   | FEI SHIUN Investment Co., Ltd.<br>Representative:<br>Xiao Wen-Huei  |   |  |
|                     | Supervisor | Lee Mei Huei  |   |  |

December 31, 2019

| Name of enterprise | Title                | Company name or representative                                      | Status of shareholding                  |  |
|--------------------|----------------------|---|---|--|
|                    |                      |   | Number of shares or Contribution amount | Shareholding or contribution ratio (%) |
| Berry AI Inc.      | Chairman             | FEI SHIUN Investment Co., Ltd.<br>Representative:<br>Shyu Jia Horng | 4,200,000 shares                        | 70 %                                   |
|                    | Director             | FEI SHIUN Investment Co., Ltd.<br>Representative:<br>Chuo Chun Hung |   |  |
|                    | Director             | Lin Yi Chung  | 450,000 shares                          | 7.5 %                                  |
|                    | Supervisor           | Lee Mei Huei  | —                                       | —                                      |
| Poindus Systems    | Chairman             | Hu Mu-zhen  | 358,000 shares                          | 1.70 %                                 |
|                    | Director             | FEI SHIUN Investment Co., Ltd.<br>Representative:<br>Liu Chiu Tsao  | 10,354,000 shares                       | 49.305 %                               |
|                    | Director             | FEI SHIUN Investment Co., Ltd.<br>Representative:<br>Chang Hong-rui |   |  |
|                    | Director             | Wang Sizhen   | —                                       | —                                      |
|                    | Independent director | Liu Tian-lai  | —                                       | —                                      |
|                    | Independent director | Huang Ren-qi  | —                                       | —                                      |
|                    | Independent director | Li Yu-jing  | —                                       | —                                      |
| Poindus Investment | Chairman             | Poindus Systems Co., Ltd. Representative:<br>Chang Hong-rui         | NTD\$ 4,100,000                         | 100 %                                  |
|                    | Director             | Poindus Systems Co., Ltd. Representative:<br>Hu Mu-zhen             |   |  |
| Poindus Systems UK | Director             | Poindus Systems Co., Ltd. Representative:<br>Hu Mu-zhen             | GBP 300,000                             | 100 %                                  |
|                    | Director             | Poindus Systems Co., Ltd. Representative:<br>Chang Hong-rui         |   |  |
| Adasys GmbH        | Executive Director   | Thomas Schäfer  | —                                       | —                                      |
| Poindus GE         | Director             | Poindus Systems Co., Ltd. Representative:<br>Chang Hong-rui         | EUR 25,000                              | 100 %                                  |
| box UK             | Chairman             | Russell Willcox   | —                                       | —                                      |
|                    | Director             | Liu Chiu Tsao   |   |  |
|                    | Director             | Chuo Chun Hung  |   |  |
|                    | Director             | Shyu Jia Horng  |   |  |
|                    | Director             | Lin Yi-zhi  |   |  |
|                    | Director             | Stuart Walker   |   |  |
|                    | Director             | Ian Patterson   |   |  |
| box Nordic         | Executive Director   | Ralf Hedvold  | —                                       | —                                      |
|                    | Director             | Russell Willcox   |   |  |
|                    | Director             | Stuart Walker   |   |  |

## 2. Business Performance of Affiliated Enterprises

December 31, 2020; Unit: NTD thousand

| Name of enterprise   | Capital | Total assets | Total Debt | Net value | Operating revenue | Operating profit | Net income (After income tax) | Earnings per share (After income tax) |
|----------------------|---------|--------------|------------|-----------|-------------------|------------------|-------------------------------|---------------------------------------|
| Flytech USA BVI      | 3,355   | 17,233       | 0          | 17,233    | 0                 | 0                | (224)                         | —                                     |
| Flytech HK BVI       | 1,723   | 135,155      | 0          | 135,155   | 0                 | 0                | 5,249                         | —                                     |
| Flytech CN BVI       | 6,544   | 127,809      | 0          | 127,809   | 0                 | (7)              | 4,047                         | —                                     |
| Fei Shiun investment | 190,000 | 383,843      | 82         | 383,761   | 0                 | (1,737)          | (3,535)                       | —                                     |
| box Holdings         | 189     | 251,061      | 40,196     | 210,865   | 0                 | 0                | 9,406                         | —                                     |
| Flytech USA          | 23,741  | 20,250       | 3,988      | 16,262    | 2,091             | (23,267)         | (224)                         | —                                     |
| Flytech HK           | 10,433  | 150,308      | 15,173     | 135,135   | 69,401            | 1,993            | 5,249                         | —                                     |
| Flytech Shanghai     | 69,089  | 125,663      | 13,432     | 112,231   | 10,518            | 4,482            | 7,800                         | —                                     |
| QIJIE Electronics    | 30,850  | 25,653       | (264)      | 25,917    | 13,465            | (1,858)          | (2,749)                       | —                                     |
| iSAPPOS Systems      | 31,690  | 0            | 0          | (267)     | 0                 | (36)             | (36)                          | —                                     |
| iRuggy Systems       | 60,000  | 30,346       | 4,370      | 25,976    | 22,141            | 220              | 167                           | —                                     |
| Berry AI             | 60,000  | 36,168       | 14,696     | 21,472    | 341               | (28,819)         | (27,245)                      | —                                     |
| Poindus Systems      | 210,000 | 676,808      | 147,323    | 529,485   | 706,067           | 50,159           | 37,518                        | 1.79                                  |
| Poindus Investment   | 4,100   | 752          | 0          | 752       | 0                 | 0                | (95)                          | —                                     |
| Poindus Systems UK   | 14,297  | 47,239       | 53,210     | (5,971)   | 81,844            | (3,157)          | (3,735)                       | —                                     |
| Adasys GmbH          | 3,292   | 113,097      | 108,073    | 5,024     | 358,160           | 2,857            | 2,537                         | —                                     |
| Poindus GE           | 1,721   | 555          | 252        | 303       | 0                 | (95)             | (95)                          | —                                     |
| box UK               | 472     | 422,933      | 184,050    | 238,883   | 512,679           | 2,262            | 9,795                         | —                                     |
| box Nordic           | 2,330   | 27,564       | 19,636     | 7,928     | 65,612            | (4,167)          | 729                           | —                                     |

## (II) Consolidated financial statement of affiliated enterprises:

The companies to be included by the Company in the consolidated financial statement of affiliated enterprises in 2020 (January 1 to December 31, 2020) pursuant to the Criteria Governing Preparation of Affiliation Reports, Consolidated Business Reports and Consolidated Financial Statements of Affiliated Enterprises are the same as those to be included into the consolidated financial statement of the parent company and subsidiaries pursuant to the Statements of International Financial Reporting Standards (IFRS) No. 10. Further, the related information to be disclosed in the consolidated financial statement of affiliated enterprises has been disclosed in the said consolidated financial statement of parent company and subsidiaries. Accordingly, it is not necessary for the Company to prepare the consolidated financial statement of affiliated enterprises separately.

## (III) Affiliated Company Affiliation Report: There is no need to prepare an affiliation report.

**8.2 Private placement of securities during the latest year up till the publication date of this annual report: None**

**8.3 Holding or disposal of the company's shares by its subsidiaries during the latest financial year, up to the publication date of this annual report: None**

**8.4. Other supplementary information: None**

**8.5 Occurrences of events defined under Article 36-3-2 of the Securities and Exchange Act in the latest year up till the publishing date of this annual report that significantly impacted shareholders' equity or security prices: None**

## **Audit Committee's Review Report**

To: The 2021 Annual Meeting of Shareholders of This Company

We reviewed the financial statements (including the consolidated financial statements) of Flytech Technology Co., Ltd. in 2020, which have been audited by Shih Wei-Ming, CPAs Wang Yung Sheng, CPA of KPMG Taiwan, with the issuance of the Auditors' Report. We also reviewed the business report and the proposal for the distribution of earnings, which we found to be conforming to applicable laws and principles. We hereby report on our review pursuant to Article 14-4 of the Securities Exchange Law and Article 219 of the Company Law.

Best regards

Flytech Technology Co., Ltd.

The head of Audit Committee: Chen Kuo Hung

March 18, 2021

## **Representation Letter**

The entities that are required to be included in the combined financial statements of Flytech Technology Co., Ltd. as of and for the year ended December 31, 2020 under the Criteria Governing the Preparation of Affiliation Reports, Consolidated Business Reports, and Consolidated Financial Statements of Affiliated Enterprises are the same as those included in the consolidated financial statements prepared in conformity with International Financial Reporting Standards No. 10 "Consolidated Financial Statements." endorsed by the Financial Supervisory Commission, In addition, the information required to be disclosed in the combined financial statements is included in the consolidated financial statements. Consequently, Flytech Technology Co., Ltd. and Subsidiaries do not prepare a separate set of combined financial statements.

Company name: Flytech Technology Co., Ltd.  
Chairman: Tai-Seng, Lam  
Date: March 18, 2021

## **Independent Auditors' Report**

To the Board of Directors  
Flytech Technology Co., Ltd.:

### **Opinion**

We have audited the consolidated financial statements of Flytech Technology Co., Ltd. (the "Company") and its subsidiaries (the "Group"), which comprise the consolidated balance sheets as of December 31, 2020 and 2019, and the consolidated statements of comprehensive income, changes in equity and cash flows for the years then ended, and notes to the consolidated financial statements, including a summary of significant accounting policies.

In our opinion, the accompanying consolidated financial statements present fairly, in all material respects, the consolidated financial position of the Group as of December 31, 2020 and 2019, and its consolidated financial performance and its consolidated cash flows for the years then ended in accordance with the Regulations Governing the Preparation of Financial Reports by Securities Issuers and with the International Financial Reporting Standards ("IFRSs"), International Accounting Standards ("IASs"), Interpretations developed by the International Financial Reporting Interpretations Committee ("IFRIC") or the former Standing Interpretations Committee ("SIC") endorsed and issued into effect by the Financial Supervisory Commission of the Republic of China.

### **Basis for Opinion**

We conducted our audits in accordance with the Regulations Governing Auditing and Certification of Financial Statements by Certified Public Accountants and the auditing standards generally accepted in the Republic of China. Our responsibilities under those standards are further described in the Auditors' Responsibilities for the Audit of the Consolidated Financial Statements section of our report. We are independent of the Group in accordance with the Certified Public Accountants Code of Professional Ethics in Republic of China (the "Code"), and we have fulfilled our other ethical responsibilities in accordance with the Code. We believe that the audit evidence we have obtained is sufficient and appropriate to provide a basis of our opinion.

### **Key Audit Matters**

Key audit matters are those matters that, in our professional judgment, were of most significance in our audit of the consolidated financial statements of the current period. These matters were addressed in the context of our audit of consolidated financial statements as a whole, and in forming our opinion thereon, and we do not provide a separate opinion on these matters.

#### **1. Revenue recognition**

Pleaser refer to Note 4(n) "Revenue from contracts with customers" for the accounting policy on revenue recognition and Note 6(s) "Revenue from contracts with customers" for the significant account disclosures of revenue.



Description of key audit matter:

The Group recognizes its revenue depending on the various trade terms in each individual sale transaction and service rendered, which are considered to be complex in determining the timing of revenue recognition. Therefore, revenue recognition has been identified as one of the key audit matters.

How the matter was addressed in our audit:

In relation to the key audit matter above, our principal audit procedures included testing the design and operating effectiveness of the Group's internal controls over financial reporting on sales; assessing whether revenue is recognized based on the trade terms with customers through reviewing the related sales contracts or other trade documents; performing a simple test on the sales transactions that took place before and after the balance sheet date, as well as reviewing and understanding the reasonableness for any identified significant sales returns and allowances that took place after the balance sheet date to ensure that revenue was recognized in the appropriate period.

2. Impairment of Goodwill

Please refer to Note 4(l) "Impairment of non-financial assets" for the significant accounting policy on goodwill impairment, Note 5(b) "Critical accounting judgments and key sources of estimation uncertainty" for estimation uncertainty of impairment of goodwill, and Note 6(k) "Intangible assets" for the related disclosures.

Description of key audit matter:

For impairment test, the recoverable amount of goodwill of relevant cash-generating units involves management's judgment and estimation with respect to the future cash flows and key assumptions which are complex and involve significant uncertainty. Accordingly, the assessment of impairment of goodwill has been identified as one of the key audit matters.

How the matter was addressed in our audit:

In relation to the key audit matter above, our principal audit procedures included: obtaining the assessment of goodwill impairment provided by the management; assessing the appropriateness of the valuation model and key assumptions, including the discount rate, expected sales growth rate and future cash flow projections, used by the management in measuring the recoverable amount; and assessing the adequacy of the Group's disclosures with respect to the related information.

**Other Matter**

The Company has additionally prepared its parent-company-only financial statements as of and for the years ended December 31, 2020 and 2019, on which we have issued an unmodified audit opinion.

## **Responsibilities of Management and Those Charged with Governance for the Consolidated Financial Statements**

Management is responsible for the preparation and fair presentation of the consolidated financial statements in accordance with the Regulations Governing the Preparation of Financial Reports by Securities Issuers and with the IFRSs, IASs, IFRIC, SIC endorsed and issued into effect by the Financial Supervisory Commission of the Republic of China, and for such internal control as management determines is necessary to enable the preparation of consolidated financial statements that are free from material misstatement, whether due to fraud or error.

In preparing the consolidated financial statements, management is responsible for assessing the Group's ability to continue as a going concern, disclosing, as applicable, matters related to going concern and using the going concern basis of accounting unless management either intends to liquidate the Group or to cease operations, or has no realistic alternative but to do so.

Those charged with governance (including the Audit Committee) are responsible for overseeing the Group's financial reporting process.

## **Auditors' Responsibilities for the Audit of the Consolidated Financial Statements**

Our objectives are to obtain reasonable assurance about whether the consolidated financial statements as a whole are free from material misstatement, whether due to fraud or error, and to issue an auditors' report that includes our opinion. Reasonable assurance is a high level of assurance, but is not a guarantee that an audit conducted in accordance with the auditing standards generally accepted in the Republic of China will always detect a material misstatement when it exists. Misstatements can arise from fraud or error and are considered material if, individually or in the aggregate, they could reasonably be expected to influence the economic decisions of users taken on the basis of these consolidated financial statements.

As part of an audit in accordance with auditing standards generally accepted in the Republic of China, we exercised professional judgment and maintained professional skepticism throughout the audit. We also:

1. Identify and assess the risks of material misstatement of the consolidated financial statements, whether due to fraud or error, design and perform audit procedures responsive to those risks, and obtain audit evidence that is sufficient and appropriate to provide a basis for our opinion. The risk of not detecting a material misstatement resulting from fraud is higher than for one resulting from error, as fraud may involve collusion, forgery, intentional omissions, misrepresentations, or the override of internal control.
2. Obtain an understanding of internal control relevant to the audit in order to design audit procedures that are appropriate in the circumstances, but not for the purpose of expressing an opinion on the effectiveness of the Group's internal control.
3. Evaluate the appropriateness of accounting policies used and the reasonableness of accounting estimates and related disclosures made by management.
4. Conclude on the appropriateness of management's use of the going concern basis of accounting and, based on the audit evidence obtained, whether a material uncertainty exists related to events or conditions that may cast significant doubt on the Group's ability to continue as a going concern. If we conclude that a material uncertainty exists, we are required to draw attention in our auditors' report to the related disclosures in the consolidated financial statements or, if such disclosures are inadequate, to modify our opinion. Our conclusions are based on the audit evidence obtained up to the date of our auditors' report. However, future events or conditions may cause the Group to cease to continue as a going concern.
5. Evaluate the overall presentation, structure and content of the consolidated financial statements, including the disclosures, and whether the consolidated financial statements represent the underlying transactions and events in a manner that achieves fair presentation.

6. Obtain sufficient appropriate audit evidence regarding the financial information of the entities or business activities within the Group to express an opinion on the consolidated financial statements. We are responsible for the direction, supervision and performance of the Group audit. We remained solely responsible for our audit opinion.

We communicate with those charged with governance regarding, among other matters, the planned scope and timing of the audit and significant audit findings, including any significant deficiencies in internal control that we identified during our audit.

We also provide those charged with governance with a statement that we have complied with relevant ethical requirements regarding independence, and to communicate with them all relationships and other matters that may reasonably be thought to bear on our independence, and where applicable, related safeguards.

From the matters communicated with those charged with governance, we determined those matters that were of most significance in the audit of the consolidated financial statements of the current period and are therefore the key audit matters. We described these matters in our auditors' report unless law or regulation precludes public disclosure about the matter or when, in extremely rare circumstances, we determined that a matter should not be communicated in our report because the adverse consequences of doing so would reasonably be expected to outweigh the public interest benefits of such communication.

The engagement partners on the audit resulting in this independent auditors' report are Wei-Ming Shih and Yung-Sheng Wang.

KPMG  
Taipei, Taiwan (Republic of China)  
March 18, 2021

#### **Notes to Readers**

The accompanying consolidated financial statements are intended only to present the consolidated financial position, financial performance and cash flows in accordance with the accounting principles and practices generally accepted in the Republic of China and not those of any other jurisdictions. The standards, procedures and practices to audit such consolidated financial statements are those generally accepted and applied in the Republic of China.

The independent auditors' report and the accompanying consolidated financial statements are the English translation of the Chinese version prepared and used in the Republic of China. If there is any conflict between, or any difference in the interpretation of the English and Chinese language independent auditors' report and consolidated financial statements, the Chinese version shall prevail.

(English Translation of Consolidated Financial Statements Originally Issued in Chinese)  
**FLYTECH TECHNOLOGY CO., LTD. AND SUBSIDIARIES**  
**Consolidated Balance Sheets**  
**December 31, 2020 and 2019**  
(Expressed in Thousands of New Taiwan Dollars)

|                                 |  | <u>December 31, 2020</u> |            | <u>December 31, 2019</u> |            |
|---------------------------------|--|--------------------------|------------|--------------------------|------------|
|                                 |  | <u>Amount</u>            | <u>%</u>   | <u>Amount</u>            | <u>%</u>   |
| <b>Assets</b>                   |  |                          |            |                          |            |
| <b>Current assets:</b>          |  |                          |            |                          |            |
| 1100                            | Cash and cash equivalents (note 6(a))  | \$ 2,540,079             | 45         | 2,210,850                | 38         |
| 1110                            | Financial assets at fair value through profit or loss—current<br>(note 6(b)) | 12,213                   | -          | 120                      | -          |
| 1136                            | Financial assets at amortised cost—current (note 6(c))                       | 109,167                  | 2          | 287,575                  | 6          |
| 1150-1170                       | Notes and accounts receivable (notes 6(d) and (s))                           | 581,181                  | 11         | 858,194                  | 15         |
| 130X                            | Inventories (notes 6(e) and 8)   | 654,962                  | 12         | 712,229                  | 12         |
| 1410-1470                       | Prepayments and other current assets   | 26,841                   | -          | 33,034                   | 1          |
| 1476                            | Other financial assets—current (note 6(d) and 8)                             | <u>46,829</u>            | <u>1</u>   | <u>10,063</u>            | <u>-</u>   |
| <b>Total current assets</b>     |  | <u>3,971,272</u>         | <u>71</u>  | <u>4,112,065</u>         | <u>72</u>  |
| <b>Non-current assets:</b>      |  |                          |            |                          |            |
| 1535                            | Financial assets at amortised cost—non-current (note 6(c))                   | 94,706                   | 2          | 17,220                   | -          |
| 1600                            | Property, plant and equipment (note 6(i) and 8)                              | 1,109,754                | 20         | 1,141,842                | 20         |
| 1755                            | Right-of-use assets (note 6(j))  | 57,644                   | 1          | 54,023                   | 1          |
| 1780                            | Intangible assets (note 6(k))  | 301,028                  | 5          | 350,067                  | 6          |
| 1840                            | Deferred income tax assets (note 6(p))                                       | 53,823                   | 1          | 70,212                   | 1          |
| 1915                            | Prepayments for equipment  | 162                      | -          | 903                      | -          |
| 1980                            | Other financial assets—non-current   | <u>3,679</u>             | <u>-</u>   | <u>3,460</u>             | <u>-</u>   |
| <b>Total non-current assets</b> |  | <u>1,620,796</u>         | <u>29</u>  | <u>1,637,727</u>         | <u>28</u>  |
| <b>Total assets</b>             |  | <u>\$ 5,592,068</u>      | <u>100</u> | <u>5,749,792</u>         | <u>100</u> |

See accompanying notes to consolidated financial statements.

(English Translation of Consolidated Financial Statements Originally Issued in Chinese)  
**FLYTECH TECHNOLOGY CO., LTD. AND SUBSIDIARIES**  
**Consolidated Balance Sheets (Continued)**  
**December 31, 2020 and 2019**  
(Expressed in Thousands of New Taiwan Dollars)

|                                 |   | <u>December 31, 2020</u> |            | <u>December 31, 2019</u> |            |
|---------------------------------|---|--------------------------|------------|--------------------------|------------|
|                                 |   | <u>Amount</u>            | <u>%</u>   | <u>Amount</u>            | <u>%</u>   |
| <b>Liabilities and Equity</b>   |   |                          |            |                          |            |
| <b>Current liabilities:</b>     |   |                          |            |                          |            |
| 2100                            | Short-term borrowings (notes 6(l) and 8)  | \$ 7,810                 | -          | 8,530                    | -          |
| 2120                            | Financial liabilities at fair value through profit or loss – current<br>(note 6(b)) | 882                      | -          | 417                      | -          |
| 2130                            | Contract liabilities – current (note 6(s))  | 60,946                   | 1          | 16,041                   | -          |
| 2150-2170                       | Notes and accounts payable  | 264,780                  | 5          | 394,221                  | 7          |
| 2200                            | Other payables (note 6(t))  | 244,448                  | 4          | 285,809                  | 5          |
| 2230                            | Current income tax liabilities  | 190,881                  | 3          | 120,271                  | 2          |
| 2250                            | Provisions – current (note 6(n))  | 32,068                   | 1          | 36,005                   | 1          |
| 2280                            | Lease liabilities – current (note 6(m))   | 28,113                   | 1          | 23,506                   | -          |
| 2300                            | Other current liabilities   | <u>20,524</u>            | <u>-</u>   | <u>29,817</u>            | <u>1</u>   |
|                                 | <b>Total current liabilities</b>  | <u>850,452</u>           | <u>15</u>  | <u>914,617</u>           | <u>16</u>  |
| <b>Non-current liabilities:</b> |   |                          |            |                          |            |
| 2570                            | Deferred income tax liabilities (note 6(p))   | 55,349                   | 1          | 61,680                   | 1          |
| 2640                            | Net defined benefit liabilities (note 6(o))   | 43,462                   | 1          | 44,581                   | 1          |
| 2580                            | Lease liabilities – non-current (note 6(m))   | <u>33,770</u>            | <u>1</u>   | <u>30,551</u>            | <u>-</u>   |
|                                 | <b>Total non-current liabilities</b>  | <u>132,581</u>           | <u>3</u>   | <u>136,812</u>           | <u>2</u>   |
|                                 | <b>Total liabilities</b>  | <u>983,033</u>           | <u>18</u>  | <u>1,051,429</u>         | <u>18</u>  |
| <b>Equity (note 6(q)):</b>      |   |                          |            |                          |            |
| 3110                            | Common stock  | 1,430,623                | 26         | 1,430,623                | 25         |
| 3200                            | Capital surplus   | 597,122                  | 10         | 674,247                  | 12         |
|                                 | Retained earnings:  |                          |            |                          |            |
| 3310                            | Legal reserve   | 1,069,391                | 19         | 995,739                  | 17         |
| 3320                            | Special reserve   | 49,402                   | 1          | 40,344                   | 1          |
| 3350                            | Unappropriated earnings   | 1,245,571                | 22         | 1,311,805                | 23         |
| 3400                            | Other equity  | <u>(57,939)</u>          | <u>(1)</u> | <u>(49,402)</u>          | <u>(1)</u> |
|                                 | <b>Equity attributable to shareholders of the Company</b>                           | <u>4,334,170</u>         | <u>77</u>  | <u>4,403,356</u>         | <u>77</u>  |
| 36XX                            | Non-controlling interests (note 6(g) and (h))                                       | <u>274,865</u>           | <u>5</u>   | <u>295,007</u>           | <u>5</u>   |
|                                 | <b>Total equity</b>   | <u>4,609,035</u>         | <u>82</u>  | <u>4,698,363</u>         | <u>82</u>  |
|                                 | <b>Total liabilities and equity</b>   | <u>\$ 5,592,068</u>      | <u>100</u> | <u>5,749,792</u>         | <u>100</u> |

See accompanying notes to consolidated financial statements.

(English Translation of Consolidated Financial Statements Originally Issued in Chinese)  
**FLYTECH TECHNOLOGY CO., LTD. AND SUBSIDIARIES**  
**Consolidated Statements of Comprehensive Income**  
**For the years ended December 31, 2020 and 2019**  
**(Expressed in Thousands of New Taiwan Dollars , Except for Earnings Per Share)**

|      |  | <b>2020</b>        |             | <b>2019</b>        |             |
|------|--|--------------------|-------------|--------------------|-------------|
|      |  | <u>Amount</u>      | <u>%</u>    | <u>Amount</u>      | <u>%</u>    |
| 4000 | <b>Revenue (notes 6(s) and 14)</b>   | \$ 4,432,961       | 100         | 5,330,472          | 100         |
| 5000 | <b>Cost of revenue (notes 6(e), (i), (j), (k), (m), (n), (o) and (t) and 12)</b>         | <u>(2,889,455)</u> | <u>(65)</u> | <u>(3,461,216)</u> | <u>(65)</u> |
|      | <b>Gross profit</b>  | <u>1,543,506</u>   | <u>35</u>   | <u>1,869,256</u>   | <u>35</u>   |
|      | <b>Operating expenses (notes 6(d), (i), (j), (k), (m), (o) and (t), and 12):</b>         |                    |             |                    |             |
| 6100 | Selling expenses   | (402,506)          | (9)         | (478,801)          | (9)         |
| 6200 | Administrative expenses  | (233,126)          | (5)         | (281,643)          | (5)         |
| 6300 | Research and development expenses  | <u>(206,482)</u>   | <u>(5)</u>  | <u>(198,835)</u>   | <u>(4)</u>  |
|      | <b>Total operating expenses</b>  | <u>(842,114)</u>   | <u>(19)</u> | <u>(959,279)</u>   | <u>(18)</u> |
|      | <b>Operating income</b>  | <u>701,392</u>     | <u>16</u>   | <u>909,977</u>     | <u>17</u>   |
|      | <b>Non-operating income and loss (note 6(m) and (u)):</b>                                |                    |             |                    |             |
| 7100 | Interest income  | 12,032             | -           | 19,384             | -           |
| 7190 | Other income   | 43,915             | 1           | 4,608              | -           |
| 7020 | Other gains and losses   | (15,168)           | -           | (48,286)           | -           |
| 7050 | Finance costs  | (2,209)            | -           | (2,839)            | -           |
| 7370 | Share of loss of associates accounted for using equity method                            | <u>-</u>           | <u>-</u>    | <u>(340)</u>       | <u>-</u>    |
|      | <b>Total non-operating income and loss</b>   | <u>38,570</u>      | <u>1</u>    | <u>(27,473)</u>    | <u>-</u>    |
| 7900 | <b>Income before income tax</b>  | 739,962            | 17          | 882,504            | 17          |
| 7950 | <b>Less: Income tax expenses (note 6(p))</b>   | <u>(142,034)</u>   | <u>(4)</u>  | <u>(160,219)</u>   | <u>(3)</u>  |
|      | <b>Net Income</b>  | <u>597,928</u>     | <u>13</u>   | <u>722,285</u>     | <u>14</u>   |
|      | <b>Other comprehensive income (loss) (notes 6(p) and (q)):</b>                           |                    |             |                    |             |
| 8310 | <b>Items that will not be reclassified subsequently to profit or loss:</b>               |                    |             |                    |             |
| 8311 | Remeasurements of defined benefit plans  | (2,463)            | -           | (5,624)            | -           |
| 8349 | Income tax related to items that will not be reclassified subsequently to profit or loss | <u>674</u>         | <u>-</u>    | <u>1,767</u>       | <u>-</u>    |
|      |  | <u>(1,789)</u>     | <u>-</u>    | <u>(3,857)</u>     | <u>-</u>    |
| 8360 | <b>Items that will be reclassified subsequently to profit or loss</b>                    |                    |             |                    |             |
| 8361 | Exchange differences on translation of foreign operations                                | (7,189)            | -           | (7,202)            | (1)         |
| 8399 | Income tax related to items that may be reclassified subsequently to profit or loss      | <u>-</u>           | <u>-</u>    | <u>-</u>           | <u>-</u>    |
|      |  | <u>(7,189)</u>     | <u>-</u>    | <u>(7,202)</u>     | <u>(1)</u>  |
|      | <b>Other comprehensive income (loss) for the year</b>                                    | <u>(8,978)</u>     | <u>-</u>    | <u>(11,059)</u>    | <u>(1)</u>  |
|      | <b>Total comprehensive income for the year</b>   | <u>\$ 588,950</u>  | <u>13</u>   | <u>711,226</u>     | <u>13</u>   |
|      | <b>Net income attributable to:</b>   |                    |             |                    |             |
| 8610 | Shareholders of the Company  | \$ 589,644         | 13          | 736,522            | 14          |
| 8620 | Non-controlling interests  | <u>8,284</u>       | <u>-</u>    | <u>(14,237)</u>    | <u>-</u>    |
|      |  | <u>\$ 597,928</u>  | <u>13</u>   | <u>722,285</u>     | <u>14</u>   |
|      | <b>Total comprehensive income attributable to:</b>                                       |                    |             |                    |             |
| 8710 | Shareholders of the Company  | \$ 581,107         | 13          | 727,464            | 14          |
| 8720 | Non-controlling interests  | <u>7,843</u>       | <u>-</u>    | <u>(16,238)</u>    | <u>(1)</u>  |
|      |  | <u>\$ 588,950</u>  | <u>13</u>   | <u>711,226</u>     | <u>13</u>   |
|      | <b>Earnings per share (in New Taiwan dollars) (note 6(r)) :</b>                          |                    |             |                    |             |
| 9750 | Basic earnings per share   | <u>\$ 4.12</u>     |             | <u>5.15</u>        |             |
| 9850 | Diluted earnings per share   | <u>\$ 4.09</u>     |             | <u>5.10</u>        |             |

See accompanying notes to consolidated financial statements.

(English Translation of Consolidated Financial Statements Originally Issued in Chinese)

**FLYTECH TECHNOLOGY CO., LTD. AND SUBSIDIARIES**

**Consolidated Statements of Changes in Equity**

**For the years ended December 31, 2020 and 2019**

(Expressed in Thousands of New Taiwan Dollars)

|   | Equity attributable to shareholders of the Company |                 |                  |                 |                         |                             |  |   |                 |                  |                           |                  |
|---|--|-----------------|------------------|-----------------|-------------------------|-----------------------------|--|---|-----------------|------------------|---------------------------|------------------|
|   | Retained earnings                                  |                 |                  |                 |                         | Total other equity interest |  |   |                 |                  | Non-controlling interests | Total equity     |
|   | Common stock                                       | Capital surplus | Legal reserve    | Special reserve | Unappropriated earnings | Total                       | Foreign currency translation differences | Remeasurements of defined benefit plans | Total           | Total            |                           |                  |
| <b>Balance at January 1, 2019</b>   | \$ 1,430,623                                       | 745,778         | 915,594          | 37,221          | 1,302,331               | 2,255,146                   | (35,732)                                 | (4,612)                                 | (40,344)        | 4,391,203        | 292,580                   | 4,683,783        |
| Appropriation of earnings:  |  |                 |                  |                 |                         |                             |  |   |                 |                  |                           |                  |
| Legal reserve   | -  | -               | 80,145           | -               | (80,145)                | -                           | -  | -                                       | -               | -                | -                         | -                |
| Special reserve   | -  | -               | -                | 3,123           | (3,123)                 | -                           | -  | -                                       | -               | -                | -                         | -                |
| Cash dividends  | -  | -               | -                | -               | (643,780)               | (643,780)                   | -  | -                                       | -               | (643,780)        | -                         | (643,780)        |
| Cash dividends from capital surplus   | -  | (71,531)        | -                | -               | -                       | -                           | -  | -                                       | -               | (71,531)         | -                         | (71,531)         |
| Changes in non-controlling interests  | -  | -               | -                | -               | -                       | -                           | -  | -                                       | -               | -                | 29,311                    | 29,311           |
| Distribution of cash dividend by subsidiaries to non-controlling interests                              | -  | -               | -                | -               | -                       | -                           | -  | -                                       | -               | -                | (10,646)                  | (10,646)         |
| Net income in 2019  | -  | -               | -                | -               | 736,522                 | 736,522                     | -  | -                                       | -               | 736,522          | (14,237)                  | 722,285          |
| Other comprehensive income (loss) in 2019   | -  | -               | -                | -               | -                       | -                           | (7,457)                                  | (1,601)                                 | (9,058)         | (9,058)          | (2,001)                   | (11,059)         |
| Total comprehensive income (loss) in 2019   | -  | -               | -                | -               | 736,522                 | 736,522                     | (7,457)                                  | (1,601)                                 | (9,058)         | 727,464          | (16,238)                  | 711,226          |
| <b>Balance at December 31, 2019</b>   | 1,430,623  | 674,247         | 995,739          | 40,344          | 1,311,805               | 2,347,888                   | (43,189)                                 | (6,213)                                 | (49,402)        | 4,403,356        | 295,007                   | 4,698,363        |
| Appropriation of earnings:  |  |                 |                  |                 |                         |                             |  |   |                 |                  |                           |                  |
| Legal reserve   | -  | -               | 73,652           | -               | (73,652)                | -                           | -  | -                                       | -               | -                | -                         | -                |
| Special reserve   | -  | -               | -                | 9,058           | (9,058)                 | -                           | -  | -                                       | -               | -                | -                         | -                |
| Cash dividends  | -  | -               | -                | -               | (572,249)               | (572,249)                   | -  | -                                       | -               | (572,249)        | -                         | (572,249)        |
| Cash dividends from capital surplus   | -  | (71,531)        | -                | -               | -                       | -                           | -  | -                                       | -               | (71,531)         | -                         | (71,531)         |
| Difference between consideration and carrying amount arising from acquisition of shares in subsidiaries | -  | (6,683)         | -                | -               | (919)                   | (919)                       | -  | -                                       | -               | (7,602)          | 7,602                     | -                |
| Reorganization under common control   | -  | 1,089           | -                | -               | -                       | -                           | -  | -                                       | -               | 1,089            | (1,089)                   | -                |
| Changes in non-controlling interests  | -  | -               | -                | -               | -                       | -                           | -  | -                                       | -               | -                | (23,852)                  | (23,852)         |
| Distribution of cash dividend by subsidiaries to non-controlling interests                              | -  | -               | -                | -               | -                       | -                           | -  | -                                       | -               | -                | (10,646)                  | (10,646)         |
| Net income in 2020  | -  | -               | -                | -               | 589,644                 | 589,644                     | -  | -                                       | -               | 589,644          | 8,284                     | 597,928          |
| Other comprehensive income (loss) in 2020   | -  | -               | -                | -               | -                       | -                           | (7,753)                                  | (784)                                   | (8,537)         | (8,537)          | (441)                     | (8,978)          |
| Total comprehensive income (loss) in 2020   | -  | -               | -                | -               | 589,644                 | 589,644                     | (7,753)                                  | (784)                                   | (8,537)         | 581,107          | 7,843                     | 588,950          |
| <b>Balance at December 31, 2020</b>   | <b>\$ 1,430,623</b>                                | <b>597,122</b>  | <b>1,069,391</b> | <b>49,402</b>   | <b>1,245,571</b>        | <b>2,364,364</b>            | <b>(50,942)</b>                          | <b>(6,997)</b>                          | <b>(57,939)</b> | <b>4,334,170</b> | <b>274,865</b>            | <b>4,609,035</b> |

See accompanying notes to consolidated financial statements.

(English Translation of Consolidated Financial Statements Originally Issued in Chinese)

**FLYTECH TECHNOLOGY CO., LTD. AND SUBSIDIARIES**

**Consolidated Statements of Cash Flows**

**For the years ended December 31, 2020 and 2019**

**(Expressed in Thousands of New Taiwan Dollars)**

|  | <u>2020</u>      | <u>2019</u>      |
|--|------------------|------------------|
| <b>Cash flows from operating activities:</b>   |                  |                  |
| Income before income tax   | \$ 739,962       | 882,504          |
| <b>Adjustments for:</b>  |                  |                  |
| <b>Adjustments to reconcile profit (loss):</b>   |                  |                  |
| Depreciation   | 121,570          | 119,226          |
| Amortization   | 49,250           | 92,813           |
| Expected credit loss (reversal)  | 1,348            | (1,620)          |
| Valuation loss on financial assets and liabilities at fair value through profit or loss, net | 1,330            | 1,147            |
| Share of loss of associates accounted for using equity method                                | -                | 340              |
| Loss on disposal of property, plant and equipment  | 63               | 382              |
| Interest expense   | 2,209            | 2,839            |
| Interest income  | (12,032)         | (19,384)         |
| Net loss on disposal of investments  | -                | 641              |
| Gain on lease modification   | (122)            | -                |
| <b>Total non-cash profit and loss</b>  | <u>163,616</u>   | <u>196,384</u>   |
| <b>Changes in operating assets and liabilities:</b>  |                  |                  |
| <b>Changes in operating assets:</b>  |                  |                  |
| Notes and accounts receivable  | 275,711          | (44,952)         |
| Inventories  | 55,984           | 105,835          |
| Prepayments and other current assets   | 6,194            | 8,620            |
| <b>Net changes in operating assets</b>   | <u>337,889</u>   | <u>69,503</u>    |
| <b>Changes in operating liabilities:</b>   |                  |                  |
| Contract liabilities   | 44,905           | (3,126)          |
| Notes and accounts payable   | (129,441)        | (171,794)        |
| Other payables   | (41,361)         | 24,131           |
| Provisions – current   | (3,936)          | 1,983            |
| Other current liabilities  | (9,293)          | 13,712           |
| Net defined benefit liabilities  | (3,329)          | (3,526)          |
| <b>Net changes in operating liabilities</b>  | <u>(142,455)</u> | <u>(138,620)</u> |
| <b>Total changes in operating assets and liabilities</b>                                     | <u>195,434</u>   | <u>(69,117)</u>  |
| Cash provided by operations  | 1,099,012        | 1,009,771        |
| Income taxes paid  | (60,691)         | (165,118)        |
| <b>Net cash provided by operating activities</b>   | <u>1,038,321</u> | <u>844,653</u>   |

(Continued)

See accompanying notes to consolidated financial statements.



(English Translation of Consolidated Financial Statements Originally Issued in Chinese)  
**FLYTECH TECHNOLOGY CO., LTD. AND SUBSIDIARIES**  
**Consolidated Statements of Cash Flows (Continued)**  
**For the years ended December 31, 2020 and 2019**  
**(Expressed in Thousands of New Taiwan Dollars)**

|  | <b>2020</b>         | <b>2019</b>      |
|--|---------------------|------------------|
| <b>Cash flows from investing activities:</b>                                     |                     |                  |
| Acquisition of financial assets at amortised cost                                | -                   | (170,912)        |
| Proceeds from disposal of financial assets at amortised cost                     | 100,921             | -                |
| Acquisition of financial assets at fair value through profit or loss             | (12,955)            | -                |
| Acquisition of investments accounted for using equity method                     | -                   | (12,340)         |
| Decrease in prepayments for investments  | -                   | 42,000           |
| Additions to property, plant and equipment (including prepayments for equipment) | (58,868)            | (63,566)         |
| Proceeds from disposal of property, plant and equipment                          | 517                 | 12               |
| Net cash flows from acquisition of subsidiaries                                  | -                   | 16,601           |
| Additions of intangible assets   | (253)               | (3,538)          |
| Decrease (increase) in other financial assets                                    | (38,671)            | 2,251            |
| Interest received  | 13,718              | 15,805           |
| <b>Net cash flows provided by (used in) investing activities</b>                 | <b>4,409</b>        | <b>(173,687)</b> |
| <b>Cash flows from financing activities:</b>                                     |                     |                  |
| Increase (decrease) in short-term borrowings                                     | (1,042)             | 52               |
| Payment of lease liabilities   | (25,497)            | (27,155)         |
| Cash dividends   | (643,780)           | (715,311)        |
| Cash dividends paid to non-controlling interests                                 | (10,646)            | (10,646)         |
| Increase in non-controlling interest   | -                   | 18,000           |
| Additions to interests in subsidiaries   | (23,852)            | -                |
| Interest paid  | (2,209)             | (2,839)          |
| <b>Net cash flows used in financing activities</b>                               | <b>(707,026)</b>    | <b>(737,899)</b> |
| <b>Effect of foreign exchange rate changes</b>                                   | <b>(6,475)</b>      | <b>(5,057)</b>   |
| <b>Net increase (decrease) in cash and cash equivalents</b>                      | <b>329,229</b>      | <b>(71,990)</b>  |
| <b>Cash and cash equivalents at beginning of period</b>                          | <b>2,210,850</b>    | <b>2,282,840</b> |
| <b>Cash and cash equivalents at end of period</b>                                | <b>\$ 2,540,079</b> | <b>2,210,850</b> |

See accompanying notes to consolidated financial statements.

(English Translation of Consolidated Financial Statements Originally Issued in Chinese)  
**FLYTECH TECHNOLOGY CO., LTD. AND SUBSIDIARIES**  
**Notes to the Consolidated Financial Statements**  
**For the years ended December 31, 2020 and 2019**  
(Expressed in Thousands of New Taiwan Dollars, Unless Otherwise Specified)

**1. Organization and business**

Flytech Technology Co., Ltd. (the “Company”) was incorporated on August 13, 1984, as a company limited by shares under the Company Act of the Republic of China (“R.O.C.”) and registered under the Ministry of Economic Affairs, R.O.C. The address of the Company’s registered office is No. 168, Sing-Ai Road, Neihu, Taipei, Taiwan. The Company and its subsidiaries (collectively the “Group”) are engaged in the design, manufacture and sale of computers and peripherals.

**2. Authorization of the consolidated financial statements**

These consolidated financial statements were authorized for issue by the Board of Directors on March 18, 2021.

**3. Application of new and revised accounting standards and interpretations:**

- (a) The impact of the International Financial Reporting Standards (“IFRSs”) endorsed by the Financial Supervisory Commission, R.O.C. (“FSC”) which have already been adopted.

The Group has initially adopted the following new amendments, which do not have a significant impact on its consolidated financial statements, from January 1, 2020:

- Amendments to IFRS 3 “Definition of a Business”
- Amendments to IFRS 9, IAS39 and IFRS7 “Interest Rate Benchmark Reform”
- Amendments to IAS 1 and IAS 8 “Definition of Material”
- Amendments to IFRS 16 “COVID-19-Related Rent Concessions”

- (b) The impact of IFRS issued by the FSC but not yet effective

The Group assesses that the adoption of the following new amendments, effective for annual period beginning on January 1, 2021, would not have a significant impact on its consolidated financial statements:

- Amendments to IFRS 4 “Extension of the Temporary Exemption from Applying IFRS 9”
- Amendments to IFRS 9, IAS 39, IFRS 7, IFRS 4 and IFRS 16 “Interest Rate Benchmark Reform – Phase 2”

## FLYTECH TECHNOLOGY CO., LTD. AND SUBSIDIARIES

### Notes to the Consolidated Financial Statements

- (c) The impact of IFRS issued by IASB but not yet endorsed by the FSC

The Group does not expect the following new and amended standards, which have yet to be endorsed by the FSC, to have a significant impact on its consolidated financial statements:

- Amendments to IFRS 10 and IAS 28 “Sale or Contribution of Assets Between an Investor and Its Associate or Joint Venture”
- IFRS 17 “Insurance Contracts” and amendments to IFRS 17 “Insurance Contracts”
- Amendments to IAS 1 “Classification of Liabilities as Current or Non-current”
- Amendments to IAS 16 “Property, Plant and Equipment – Proceeds before Intended Use”
- Amendments to IAS 37 “Onerous Contracts – Cost of Fulfilling a Contract”
- Annual Improvements to IFRS Standards 2018-2020
- Amendments to IFRS 3 “Reference to the Conceptual Framework”
- Amendments to IAS 1 “Disclosure of Accounting Policies”
- Amendments to IAS 8 “Definition of Accounting Estimates”

#### 4. Summary of significant accounting policies

The significant accounting policies presented in the consolidated financial statements are summarized as follows and have been applied consistently to all periods presented in these financial statements.

- (a) Statement of compliance

The Group’s accompanying consolidated financial statements have been prepared in accordance with the “Regulations Governing the Preparation of Financial Reports by Securities Issuers” (the “Regulations”) and the IFRSs, IASs, IFRIC Interpretations and SIC Interpretations endorsed and issued into effect by the FSC (collectively “Taiwan-IFRSs”).

- (b) Basis of preparation

- (i) Basis of measurement

The accompanying consolidated financial statements have been prepared on a historical cost basis except for the following items in the balance sheets:

- 1) Financial instruments at fair value through profit or loss (including derivative financial instruments and contingent consideration);
- 2) The defined benefit liabilities are measured at present value of the benefit obligation less the fair value of plan assets.

- (ii) Functional and presentation currency

The functional currency of each Group entity is determined based on the primary economic environment in which the entity operates. The Group’s consolidated financial statements are presented in New Taiwan dollars, which is the Company’s functional currency. Except when otherwise indicated, all financial information presented in New Taiwan dollars has been rounded to the nearest thousand.

**FLYTECH TECHNOLOGY CO., LTD. AND SUBSIDIARIES**  
**Notes to the Consolidated Financial Statements**

(c) Basis of consolidation

(i) Principles of preparation of consolidated financial statements

The accompanying consolidated financial statements incorporate the financial statements of the Company and its controlled entities (the subsidiaries) in which the Company is exposed, or has right, to variable returns from its involvement with the investee and has the ability to affect those returns through its power over the investee.

The financial statements of the subsidiaries are included in the consolidated financial statements from the date that control commences until the date that control ceases. All significant inter-company balances, transactions, and the resulting unrealized income and loss are eliminated on consolidation. Total comprehensive income (loss) of a subsidiary is attributed to the shareholders of the Company and the non-controlling interests even if this results in the non-controlling interests having a deficit balance.

When necessary, financial statements of subsidiaries are adjusted to align their accounting policies with those adopted by the Group.

Changes in the Group's ownership interest in a subsidiary that do not result in a loss of control are accounted for as equity transactions. The difference between the adjustment of the non-controlling interests and the fair value of the consideration paid or received is recognized in equity and attributed to the shareholders of the Company.

(ii) List of subsidiaries included in the consolidated financial statements

| Name of Investor     | Name of Investee                                      | Principal activities   | Percentage of Ownership |                   | Note   |
|----------------------|---|--|-------------------------|-------------------|--------|
|                      |   |  | December 31, 2020       | December 31, 2019 |        |
| The Company          | Flytech USA International Co., Ltd. (Flytech USA BVI) | Investment holding   | 100.00%                 | 100.00%           | -      |
| The Company          | Flytech HK International Co., Ltd. (Flytech HK BVI)   | Investment holding   | 100.00%                 | 100.00%           | -      |
| The Company          | Flytech CN International Co., Ltd. (Flytech CN BVI)   | Investment holding   | 100.00%                 | 100.00%           | -      |
| The Company          | Fei Shiun Investment Co. Ltd. (Fei Shiun Investment)  | Investment holding   | 100.00%                 | 100.00%           | -      |
| The Company          | Box Technologies (Holdings) Ltd. (Box Holdings)       | Investment holding   | 100.00%                 | 100.00%           | -      |
| Flytech USA BVI      | Flytech Technology (U.S.A.) Inc. (Flytech USA)        | Sale of computers and peripherals  | 100.00%                 | 100.00%           | -      |
| Flytech HK BVI       | Flytech Technology Hong Kong Ltd. (Flytech HK)        | Sale of computers and peripheral equipment   | 100.00%                 | 100.00%           | -      |
| Flytech CN BVI       | Flytech Technology (Shanghai) Co., Ltd. (Flytech CN)  | Sale of computers and peripherals  | 100.00%                 | 100.00%           | -      |
| Flytech CN BVI       | Qijie Electronics(Shenzhen) Co.,Ltd (Qijie)           | Sale of computers and peripherals  | -                       | 60.00%            | Note 1 |
| Flytech HK           | iSAPPOS System co., Ltd. (iSAPPOS)                    | Sale of computers and peripherals  | 100.00%                 | 100.00%           | Note3  |
| Fei Shiun Investment | Berry AI Inc. (Berry AI)                              | Operating software design and data processing services, and integrating software and hardware services | 70.00%                  | 70.00%            | -      |

## FLYTECH TECHNOLOGY CO., LTD. AND SUBSIDIARIES

### Notes to the Consolidated Financial Statements

| Name of<br>Investor  | Name of Investee  | Principal activities              | Percentage of Ownership |                      | Note   |
|----------------------|---|-----------------------------------|-------------------------|----------------------|--------|
|                      |   |                                   | December 31,<br>2020    | December 31,<br>2019 |        |
| Fei Shiun Investment | iRuggy System Co., Ltd. (iRuggy System)                           | Sale of computers and peripherals | 100.00%                 | 80.00%               | Note 2 |
| Fei Shiun Investment | Poindus Systems Corporation (Poindus Systems)                     | Sale of computers and peripherals | 49.31%                  | 49.31%               |        |
| Poindus Systems      | Poindus Investment Co., Ltd. (Poindus Investment)                 | Investment holding                | 49.31%                  | 49.31%               | -      |
| Poindus Systems      | Poindus Systems UK Limited (Poindus UK)                           | Sale of computers and peripherals | 49.31%                  | 49.31%               | -      |
| Poindus Systems      | Adasys GmbH Elektronische Komponenteas (Adasys)                   | Sale of computers and peripherals | 49.31%                  | 49.31%               | -      |
| Poindus Systems      | Qijie Electronics (Shenzhen) Co., Ltd. (Qijie)                    | Sale of computers and peripherals | 49.31%                  | -                    | Note 1 |
| Poindus Investment   | Poindus Systems GmbH GroBhandel mit EDV. Oberursel (Poindus GmbH) | Sale of computers and peripherals | 49.31%                  | 49.31%               | -      |
| Box Holdings         | Box Technologies Limited (Box UK)                                 | Sale of computers and peripherals | 100.00%                 | 100.00%              | -      |
| Box Holdings         | BTechnologies AB (Box Nordic)                                     | Sale of computers and peripherals | 100.00%                 | 100.00%              | -      |

Note 1: Formerly Qijie was an associate accounted for using the equity method; the Group acquired additional shares of Qijie and obtained control over it in October 2019. Accordingly, Qijie was included in the accompanying consolidated financial statements from the date the control commenced. In July 2020, Poindus Systems directly owned the entire shares of Qijie by reorganization under common control.

Note 2: The Group acquired additional 20% interest of iRuggy System in 2020.

Note 3: ISAPPOS was liquidated in June 2020, wherein the liquidation process had been completed in February 2021.

(iii) List of subsidiaries which are not included in the consolidated financial statements: None.

(d) Foreign currency

(i) Foreign currency transactions

Foreign currency transactions are translated into the functional currency using the exchange rates prevailing at the dates of the transactions. At the end of each subsequent reporting period, monetary items denominated in foreign currencies are translated into the functional currencies using the exchange rate at that date. Non-monetary items denominated in foreign currencies that are measured at fair value are translated into the functional currencies using the exchange rate at the date that the fair value was determined. Non-monetary items denominated in foreign currencies that are measured based on historical cost are translated using the exchange rate at the date of the transaction.

Exchange differences are generally recognized in profit or loss, except for an investment in equity securities designated as at fair value through other comprehensive income are recognized in other comprehensive income.

## FLYTECH TECHNOLOGY CO., LTD. AND SUBSIDIARIES

### Notes to the Consolidated Financial Statements

(ii) Foreign operations

The assets and liabilities of foreign operations, including goodwill and fair value adjustments arising on acquisition, are translated into the presentation currency at the exchange rates at the reporting date. The income and expenses of foreign operations are translated into the presentation currency at the average exchange rate. Exchange differences are recognized in other comprehensive income.

On the disposal of a foreign operation which involves a loss of control over a subsidiary or loss of significant influence over an associate that includes a foreign operation, all of the exchange differences accumulated in equity in respect of that operation attributable to the shareholders of the Group are entirely reclassified to profit or loss. In the case of a partial disposal that does not result in the Group losing control over a subsidiary, the proportionate share of accumulated exchange differences is reclassified to non-controlling interests. For a partial disposal of the Group's ownership interest in an associate or joint venture, the proportionate share of the accumulated exchange differences in equity is reclassified to profit or loss.

(e) Classification of current and non-current assets and liabilities

An asset is classified as current when one of following criteria is met; all other assets are classified as non-current assets.

- (i) It is expected to be realized, or intended to be sold or consumed in the normal operating cycle;
- (ii) It is held primarily for the purpose of trading;
- (iii) It is expected to be realized within twelve months after the reporting date; or
- (iv) The asset is cash or a cash equivalent unless the asset is restricted from being exchanged or used to settle a liability for at least twelve months after the reporting period.

A liability is classified as current when one of following criteria is met; all other liabilities are classified as non-current liabilities:

- (i) It is expected to be settled in the normal operating cycle;
- (ii) It is held primarily for the purpose of trading;
- (iii) It is due to be settled within twelve months after the reporting period; or
- (iv) The Group does not have an unconditional right to defer settlement of the liability for at least twelve months after the reporting period.

(f) Cash and cash equivalents

Cash comprises cash on hand, demand deposits and checking deposits. Cash equivalents are short-term and highly liquid investments that are readily convertible to known amounts of cash and are subject to an insignificant risk of changes in value. Time deposits that meet the aforesaid criteria and are not held for investing purposes are also classified as cash equivalents.

## FLYTECH TECHNOLOGY CO., LTD. AND SUBSIDIARIES

### Notes to the Consolidated Financial Statements

(g) Financial instruments

Trade receivables are initially recognized when they are originated. All other financial assets and financial liabilities are initially recognized when the Group becomes a party to the contractual provisions of the instrument. A financial asset (unless it is a trade receivable without a significant financing component) or financial liability is initially measured at fair value plus, for an item not at fair value through profit or loss (FVTPL), transaction costs that are directly attributable to its acquisition or issue. A trade receivable without a significant financing component is initially measured at the transaction price.

(i) Financial assets

On initial recognition, financial assets are classified into the following categories: measured at amortized cost and fair value through profit or loss (FVTPL). Regular way purchases or sales of financial assets are recognized or derecognized on a trade-date basis.

The Group shall reclassify all affected financial assets on the first day of the first reporting period only when it changes its business model for managing its financial assets.

1) Financial assets measured at amortized cost

A financial asset is measured at amortized cost if it meets both of the following conditions and is not designated as at FVTPL:

- it is held within a business model whose objective is to hold assets to collect contractual cash flows; and
- its contractual terms give rise on specified dates to cash flows that are solely payments of principal and interest on the principal amount outstanding.

These assets are subsequently measured at amortized cost, which is the amount at which the financial asset is measured at initial recognition, plus/minus, the cumulative amortization using the effective interest method, adjusted for any loss allowance. Interest income, foreign exchange gains and losses, and impairment loss, are recognized in profit or loss. Any gain or loss on derecognition is recognized in profit or loss.

2) Fair value through profit or loss (FVTPL)

All financial assets not classified as amortized cost described as above are measured at FVTPL, including derivative financial assets. On initial recognition, the Group may irrevocably designate a financial asset, which meets the requirements to be measured at amortized cost, as at FVTPL if doing so eliminates or significantly reduces an accounting mismatch that would otherwise arise.

These assets are subsequently measured at fair value. Net gains and losses, including any interest or dividend income, are recognized in profit or loss.

## FLYTECH TECHNOLOGY CO., LTD. AND SUBSIDIARIES

### Notes to the Consolidated Financial Statements

#### 3) Impairment of financial assets

The Group recognizes loss allowances for expected credit losses (ECL) on financial assets measured at amortized cost (including cash and cash equivalents, notes and accounts receivable, other receivables, financial assets at amortised cost and other financial assets).

The Group measures loss allowances at an amount equal to lifetime ECL, except for the following financial assets which are measured as 12-month ECL:

- bank balances for which credit risk (i.e. the risk of default occurring over the expected life of the financial instrument) has not increased significantly since initial recognition.

Loss allowance for accounts receivables are always measured at an amount equal to lifetime ECL.

Lifetime ECL are the ECL that result from all possible default events over the expected life of a financial instrument. 12-month ECL are the portion of ECL that result from default events that are possible within the 12 month after the reporting date (or a shorter period if the expected life of the instrument is less than 12 months).

The maximum period considered when estimating ECL is the maximum contractual period over which the Group is exposed to credit risk.

When determining whether the credit risk of a financial asset has increased significantly since initial recognition and when estimating ECL, the Group considers reasonable and supportable information that is relevant and available without undue cost or effort. This includes both quantitative and qualitative information and analysis based on the Group's historical experience and informed credit assessment as well as forward-looking information.

ECL are a probability-weighted estimate of credit losses. Credit losses are measured as the present value of all cash shortfalls (i.e., the difference between the cash flows due to the Group in accordance with the contract and the cash flows that the Group expects to receive). ECL are discounted at the effective interest rate of the financial asset.

Loss allowances for financial assets measured at amortized cost are deducted from the gross carrying amount of the assets.

The gross carrying amount of a financial asset is written off, either partially or in full, to the extent that there is no realistic prospect of recovery. The Group individually makes an assessment with respect to the timing and amount of write-off based on whether there is a reasonable expectation of recovery. The Group expects no significant recovery from the amount written off. However, financial assets that are written off could still be subject to enforcement activities in order to comply with the Group's procedures for recovery of amounts due.



## **FLYTECH TECHNOLOGY CO., LTD. AND SUBSIDIARIES**

### **Notes to the Consolidated Financial Statements**

#### 4) Derecognition of financial assets

The Group derecognized a financial asset when the contractual rights to the cash flows from the financial asset expire, or it transfers the rights to receive the contractual cash flows in a transaction in which substantially all of the risks and rewards of ownership of the financial asset are transferred or in which the Group neither transfers nor retains substantially all of the risks and rewards of ownership and it does not retain control of the financial asset.

The Group enters into transactions whereby it transfers assets recognized in its statement of balance sheet, but retains either all or substantially all of the risks and rewards of the transferred assets. In these cases, the transferred assets are not derecognized.

#### (ii) Financial liabilities

##### 1) Financial liabilities

Financial liabilities are classified as measured at amortized cost or FVTPL. A financial liability is classified as at FVTPL if it is classified as held-for-trading, it is a derivative or it is designated as such on initial recognition. Financial liabilities at FVTPL are measured at fair value and net gains and losses, including any interest expense, are recognized in profit or loss.

Other financial liabilities are subsequently measured at amortized cost using the effective interest method. Interest expense and foreign exchange gains and losses are recognized in profit or loss. Any gain or loss on derecognition is also recognized in profit or loss.

##### 2) Derecognition of financial liabilities

The Group derecognizes a financial liability when its contractual obligation has been fulfilled or cancelled, or has expired. The Group also derecognizes a financial liability when its terms are modified and the cash flows of the modified liability are substantially different, in which case a new financial liability based on the modified terms is recognized at fair value.

On derecognition of a financial liability, the difference between the carrying amount of a financial liability extinguished and the consideration paid (including any non-cash assets transferred or liabilities assumed) is recognized in profit or loss.

##### 3) Offsetting of financial assets and liabilities

Financial assets and financial liabilities are offset and the net amount presented in the statement of balance sheet when, and only when, the Group has the legally enforceable right to set off the amounts and it intends either to settle them on a net basis or to realize the asset and settle the liability simultaneously.

## FLYTECH TECHNOLOGY CO., LTD. AND SUBSIDIARIES

### Notes to the Consolidated Financial Statements

(iii) Derivative financial instruments

The Group holds derivative financial instruments to hedge its foreign currency exposures. Derivatives are initially measured at fair value, and attributable transaction costs are recognized in profit or loss as incurred. Subsequent to initial recognition, derivatives are measured at fair value, and changes therein are recognized in profit or loss. If the valuation of a derivative instrument results in a positive fair value, it is classified as a financial asset; otherwise, it is classified as a financial liability.

(h) Inventories

Inventories are measured at the lower of cost and net realizable value. The cost of inventories is calculated based on the weighted-average method and includes expenditure incurred in acquiring the inventories, production or conversion costs, and other cost incurred in bringing them to a location and condition ready for sale. Fixed manufacturing overhead is allocated to finished products and work in process based on the higher of normal capacity or actual capacity; variable manufacturing overhead is allocated based on the actual capacity of machinery and equipment. Net realizable value represents the estimated selling price in the ordinary course of business, less all estimated costs of completion and necessary selling expenses.

(i) Property, plant and equipment

(i) Recognition and measurement

Items of property, plant and equipment are measured at cost, which includes capitalized borrowing costs, less accumulated depreciation and accumulated impairment losses.

If significant parts of an item of property, plant and equipment have different useful lives, they are accounted for as separate items (major components) of property, plant and equipment.

Any gain or loss on disposal of an item of property, plant and equipment is recognized in profit or loss.

(ii) Subsequent costs

Subsequent expenditure is capitalized only if it is probable that the future economic benefits associated with the expenditure will flow to the Group.

(iii) Depreciation

Depreciation is calculated on the cost of an asset less its residual value and is recognized in profit or loss on a straight-line basis over the estimated useful lives of each component of an item of property, plant and equipment. Land is not depreciated.

The estimated useful lives for property, plant and equipment are as follows: machinery and equipment - 3 to 12 years; mold equipment - 4 to 10 years; office equipment - 3 to 15 years; other equipment - 2 to 10 years; buildings are depreciated over the following useful lives of significant individual components: main structure - 50 years; mechanical & electrical power equipment - 20 years; and air-conditioning system - 10 years.

## FLYTECH TECHNOLOGY CO., LTD. AND SUBSIDIARIES

### Notes to the Consolidated Financial Statements

Depreciation methods, useful lives, and residual values are reviewed at each reporting date, with the effect of any changes in estimate accounted for on a prospective basis.

(j) Leases

(i) Identifying a lease

At inception of a contract, the Group assesses whether a contract is, or contains, a lease. A contract is, or contains, a lease if the contract conveys the right to control the use of an identified asset for a period of time in exchange for consideration. To assess whether a contract conveys the right to control the use of an identified asset, the Group assesses whether:

- 1) the contract involves the use of an identified asset – this may be specified explicitly or implicitly, and should be physically distinct or represent substantially all of the capacity of a physically distinct asset. If the supplier has a substantive substitution right, then the asset is not identified; and
- 2) the customer has the right to obtain substantially all of the economic benefits from use of the asset throughout the period of use; and
- 3) the customer has the right to direct the use of the asset if either:
  - the customer has the right to direct how and for what purpose the asset is used throughout the period of use; or
  - the relevant decisions about how and for what purpose the asset is used are predetermined and:
    - the customer has the right to operate the asset throughout the period of use, without the supplier having the right to change those operating instructions; or
    - the customer designed the asset in a way that predetermines how and for what purpose it will be used throughout the period of use.

At inception or on reassessment of a contract that contains a lease component, the Group allocates the consideration in the contract to each lease component on the basis of their relative stand-alone prices. However, for the leases of land and buildings in which it is a lessee, the Group has elected not to separate non-lease components and account for the lease and non-lease components as a single lease component.

(ii) As a lessee

The Group recognizes a right-of-use asset and a lease liability at the lease commencement date. The right-of-use asset is initially measured at cost, which comprises the initial amount of the lease liability adjusted for any lease payments made at or before the commencement date, plus any initial direct costs incurred and an estimate of costs to dismantle and remove the underlying asset or to restore the underlying asset or the site on which it is located, less any lease incentives received.

## **FLYTECH TECHNOLOGY CO., LTD. AND SUBSIDIARIES**

### **Notes to the Consolidated Financial Statements**

The right-of-use asset is subsequently depreciated using the straight-line method from the commencement date to the earlier of the end of the useful life of the right-of-use asset or the end of the lease term. In addition, the right-of-use asset is periodically reduced by impairment losses, if any, and adjusted for certain remeasurements of the lease liability.

The lease liability is initially measured at the present value of the lease payments that are not paid at the commencement date, discounted using the interest rate implicit in the lease or, if that rate cannot be reliably determined, the Group's incremental borrowing rate. Generally, the Group uses its incremental borrowing rate as the discount rate.

Lease payments included in the measurement of the lease liability comprise the following:

- fixed payments, including in-substance fixed payments;
- variable lease payments that depend on an index or a rate, initially measured using the index or rate as at the commencement date.

The lease liability is measured at amortized cost using the effective interest method. It is remeasured when:

- there is a change in future lease payments arising from the change in an index or rate; or
- there is a change of its assessment on whether it will exercise a purchase, extension or termination option; or
- there is any lease modifications in lease subject, scope of the lease or other terms.

When the lease liability is remeasured, other than lease modifications, a corresponding adjustment is made to the carrying amount of the right-of-use asset, or in profit and loss if the carrying amount of the right-of-use asset has been reduced to zero.

When the lease liability is remeasured to reflect the partial or full termination of the lease for lease modifications that decrease the scope of the lease, the Group accounts for the remeasurement of the lease liability by decreasing the carrying amount of the right-of-use asset to reflect the partial or full termination of the lease, and recognize in profit or loss any gain or loss relating to the partial or full termination of the lease.

The Group presents right-of-use assets that do not meet the definition of investment and lease liabilities as a separate line item respectively in the balance sheets.

The Group has elected not to recognize right-of-use assets and lease liabilities for short-term leases and leases of low-value assets. The Group recognizes the lease payments associated with these leases as an expense on a straight-line basis over the lease term.

## FLYTECH TECHNOLOGY CO., LTD. AND SUBSIDIARIES

### Notes to the Consolidated Financial Statements

(k) Intangible assets

(i) Goodwill

Goodwill arising from acquisitions of subsidiaries is accounted for as intangible assets. Goodwill arising from acquisitions of associates is included in the carrying amount of investments in associates. Goodwill is not amortized but is measured at cost less accumulated impairment losses.

(ii) Other intangible assets

Trademarks, patents, acquired software and technology, and customer relationships acquired in a business combination are measured at fair value at the acquisition date. Subsequent to the initial recognition, such intangible assets are carried at cost less accumulated amortization and accumulated impairment losses. Other separately acquired intangible assets are carried at cost less accumulated amortization and accumulated impairment loss. Amortization is recognized in profit or loss on a straight-line basis over the following estimated useful lives: Trademarks - 5 to 7 years; patents and technology - 5 years; customer relationships - 5 to 7 years; acquired software - 2 to 5 years.

Amortization methods, useful lives and residual values are reviewed at each reporting date and adjusted if appropriate.

(l) Impairment of non-financial assets

At each reporting date, the Group reviews the carrying amounts of its non-financial assets (other than inventories and deferred tax assets) to determine whether there is any indication of impairment. If any such indication exists, then the asset's recoverable amount is estimated. Goodwill is tested annually for impairment.

For impairment testing, assets are grouped together into the smallest group of assets that generates cash inflows from continuing use that are largely independent of the cash inflows of other assets or CGUs. Goodwill arising from a business combination is allocated to CGUs or groups of CGUs that are expected to benefit from the synergies of the combination.

The recoverable amount of an asset or CGU is the greater of its value in use and its fair value less costs to sell. Value in use is based on the estimated future cash flows, discounted to their present value using a pre-tax discount rate that reflects current market assessments of the time value of money and the risks specific to the asset or CGU.

An impairment loss is recognized if the carrying amount of an asset or CGU exceeds its recoverable amount. Impairment losses are recognized in profit or loss. They are allocated first to reduce the carrying amount of any goodwill allocated to the CGU, and then to reduce the carrying amounts of the other assets in the CGU on a pro rata basis.

An impairment loss in respect of goodwill is not reversed. For other assets, an impairment loss is reversed only to the extent that the asset's carrying amount does not exceed the carrying amount that would have been determined, net of depreciation or amortization, if no impairment loss had been recognized.

## FLYTECH TECHNOLOGY CO., LTD. AND SUBSIDIARIES

### Notes to the Consolidated Financial Statements

(m) Provisions

Provisions are recognized when the Group has a present obligation as a result of a past event, it is probable that the Group will be required to settle the obligation, and a reliable estimate can be made of the amount of the obligation.

A provision for warranties is recognized when the underlying products or services are sold, based on historical warranty data and the weighting of all possible outcomes against their associated probabilities.

(n) Revenue from contracts with customers

Revenue is measured based on the consideration to which the Group expects to be entitled in exchange for transferring goods or services to a customer. The Group recognizes revenue when it satisfies a performance obligation by transferring its control of goods or services to a customer. The accounting policies for the Group's main types of revenue are explained below.

(i) Sale of goods

The Group recognizes revenue when its control of the products has been transferred, being when the products are delivered to the customer, the customer has full discretion over the channel and price to sell the products, and there is no unfulfilled obligation that could affect the customer's acceptance of the products. Delivery occurs when the products have been shipped to the specific location, the risks of obsolescence and loss have been transferred to the customer, and either the customer has accepted the products in accordance with the sales contract or the Group has objective evidence that all criteria for acceptance have been satisfied.

The Group grants its customers the right to return the faulty goods under the standard warranty terms and has recognized warranty provisions for this obligation, please refer to note 6(m).

A receivable is recognized when the goods are delivered as this is the point in time that the Group has a right to an amount of consideration that is unconditional.

(ii) Revenue from service rendered

Revenue from service rendered is recognized by reference to the stage of completion at the reporting date.

(o) Government grants

The Group recognizes an unconditional government grant related to its operation and salary as other income when the grant becomes receivable.

(p) Employee benefits

(i) Defined contribution plans

Obligations for contributions to defined contribution plans are expensed as the related service is provided.

## FLYTECH TECHNOLOGY CO., LTD. AND SUBSIDIARIES

### Notes to the Consolidated Financial Statements

#### (ii) Defined benefit plans

The Group's net obligation in respect of defined benefit plans is calculated separately for each the plan by estimating the amount of future benefit that employees have earned in the current and prior periods, discounting that amount and deducting the fair value of any plan assets. The discount rate for calculating the present value of the defined benefit obligation refers to the interest rate of high-quality government bonds that are denominated in the currency in which the benefits will be paid, and that have terms to maturity approximating the term of the related pension obligation. The defined benefit obligation is calculated annually by qualified actuaries using the projected unit credit method.

The remeasurements of the net defined benefit liability (asset) comprise (i) actuarial gains and losses; (ii) return on plan assets, excluding amounts included in net interest on the net defined benefit liability (asset); and (iii) any change in the effect of the asset ceiling, excluding amounts included in net interest on the net defined benefit liability (asset). The remeasurements of the net defined benefit liability (asset) are recognized in other comprehensive income and reflected in other equity.

The Group recognizes gains or losses on the curtailment or settlement of a defined benefit plan when the curtailment or settlement occurs. The gain or loss on curtailment or settlement comprises any resulting change in the fair value of plan assets and any change in the present value of the defined benefit obligation.

#### (iii) Short-term employee benefits

Short-term employee benefit obligations are measured on an undiscounted basis and are expensed during the period in which employees render services. A liability is recognized for the amount expected to be paid under short-term cash bonus or profit-sharing plans if the Group has a present legal or constructive obligation to make such payments as a result of past service provided by the employees, and the obligation can be estimated reliably.

#### (q) Share-based payment

The grant-date fair value of equity-settled share-based payment arrangements granted to employees is generally recognized as an expense, with a corresponding increase in equity, over the vesting period of the awards. The amount recognized as an expense is adjusted to reflect the number of awards for which the related service and non-market performance conditions are expected to be met, such that the amount ultimately recognized is based on the number of awards that meet the related service and non-market performance conditions at the vesting date.

#### (r) Income taxes

Income taxes comprise current taxes and deferred taxes. All current and deferred taxes are recognized in profit or loss except for expenses related to business combinations or recognized directly in equity or other comprehensive income.

## **FLYTECH TECHNOLOGY CO., LTD. AND SUBSIDIARIES**

### **Notes to the Consolidated Financial Statements**

Current taxes comprise the expected tax payables or receivables on the taxable profits (losses) for the year and any adjustment to the tax payable or receivable in respect of previous years. The amount of current tax payables or receivables are the best estimate of the tax amount expected to be paid or received that reflects uncertainty related to income taxes, if any. It is measured using tax rates enacted or substantively enacted at the reporting date.

Deferred income taxes are recognized in respect of temporary differences between the carrying amounts of assets and liabilities for financial reporting purposes and their respective tax bases. Deferred taxes are not recognized for:

- (i) Temporary differences on the initial recognition of assets or liabilities in a transaction that is not a business combination and that affects neither accounting nor taxable profit (losses) at the time of transaction;
- (ii) Temporary differences related to investments in subsidiaries, associates and joint arrangements to the extent that the Group is able to control the timing of the reversal of the temporary differences and it is probable that they will not reverse in the foreseeable future; and
- (iii) Taxable temporary differences arising on the initial recognition of goodwill.

Deferred taxes are measured at tax rates that are expected to be applied to temporary differences when they reverse, using tax rates enacted or substantively enacted at the reporting date, and reflect uncertainty related to income taxes, if any.

Deferred tax assets and liabilities are offset if the following criteria are met:

- (i) the Group has a legally enforceable right to set off current tax assets against current tax liabilities; and
- (ii) the deferred tax assets and the deferred tax liabilities relate to income taxes levied by the same taxation authority on either:
  - 1) the same taxable entity; or
  - 2) different taxable entities which intend to settle current tax assets and liabilities on a net basis, or to realize the assets and liabilities simultaneously, in each future period in which significant amounts of deferred tax liabilities or assets are expected to be settled or recovered.

Deferred tax assets are recognized for unused tax losses, tax credits, and deductible temporary differences to the extent that it is probable that future taxable profits will be available against which they can be utilized. Deferred tax assets are reviewed at each reporting date and reduced to the extent that it is no longer probable that the related tax benefit will be realized; such reductions are reversed when the probability of future taxable profits improves.



## FLYTECH TECHNOLOGY CO., LTD. AND SUBSIDIARIES

### Notes to the Consolidated Financial Statements

(s) Business combinations

Goodwill is measured as the excess of the acquisition-date fair value of consideration transferred (including any non-controlling interest in the acquiree) over the net of the acquisition-date amounts of the identifiable assets acquired and liabilities assumed (generally at fair value). If the residual balance is negative, the Group shall re-assess whether it has correctly identified all of the assets acquired and liabilities assumed and recognize any additional assets or liabilities that are identified in that review, and shall recognize a gain on the bargain purchase thereafter.

If the initial accounting for a business combination is incomplete by the end of the reporting period in which the combination occurs, provisional amounts for the items for which the accounting is incomplete are reported in the financial statements. During the measurement period, the provisional amounts recognized at the acquisition date are retrospectively adjusted to reflect new information obtained about facts and circumstances that existed as of the acquisition date. The measurement period shall not exceed one year from the acquisition date.

Acquisition-related costs are expensed as incurred except for the costs related to issuance of debt or equity instruments.

Components of non-controlling interests in an acquiree that are present ownership interests and entitle their holders to a proportionate share of the entity's net assets in the event of liquidation are measured individually at either fair value or the present ownership instruments' proportionate share in the recognized amounts of the acquiree's identifiable net assets. All other components of non-controlling interests are measured at their acquisition-date fair values or other measurement basis in accordance with Taiwan-IFRSs.

In a business combination achieved in stages, the Group remeasures its previously held equity interest in the acquiree at its acquisition-date fair value, and recognizes the resulting gain or loss, if any, is recognized in profit or loss. In prior reporting periods, the Group may have recognized changes in the value of its equity interest in the acquiree in other comprehensive income. If so, the amount that was recognized in other comprehensive income will be recognized on the same basis as would be required if the Group had disposed directly of the previously held equity interest. If the disposal of the equity interest required a reclassification to profit or loss, such an amount will be reclassified to profit or loss.

The Group recognizes the acquisition-date fair value of the contingent consideration as part of the consideration transferred. The cost of the acquisition and measuring goodwill will retrospectively be adjusted when some changes in the fair value of contingent consideration that the Group recognizes have been made after the acquisition date. Measurement period adjustments is the result of additional information that the Group obtained after that date about facts and circumstances that existed at the acquisition date. The measurement period will not exceed one year from the acquisition date. The Group accounts for the changes in the fair value of contingent consideration that are not measurement period adjustments. The Group's accounting treatment should be based on the classification of contingent consideration. Contingent consideration classified as equity shall not be remeasured and its subsequent settlement will be accounted for within equity.

Others will be measured at fair value at each reporting date and changes in fair value will be recognized in profit or loss or other comprehensive income.

## FLYTECH TECHNOLOGY CO., LTD. AND SUBSIDIARIES

### Notes to the Consolidated Financial Statements

(t) Group reorganization under common control

As of July 1, 2020, Poindus Systems obtained control over Qijie by reorganization under common control. The assets and liabilities acquired from Qijie was measured using the book value method, and any differences between the consideration given by the Group and the aggregated book value of the assets and liabilities of Qijie were accounted for as addition (deduction) in capital surplus arising from share premium. However, if the share premium is insufficient, the remaining balance will be accounted for as a deduction from unappropriated retained earnings.

(u) Earnings per share (“EPS”)

The basic and diluted EPS attributable to shareholders of the Company are disclosed in the consolidated financial statements. Basic EPS are calculated by dividing net income attributable to shareholders of the Company by the weighted-average number of common shares outstanding during the year. In calculating diluted EPS, the net income attributable to shareholders of the Company and weighted-average number of common shares outstanding during the year are adjusted for the effects of dilutive potential common shares. The Group’s dilutive potential common shares include profit sharing for employees to be settled in the form of common stock.

(v) Operating segments

An operating segment is a component of the Group that engages in business activities from which it may earn revenues and incur expenses (including revenues and expenses relating to transactions with other components of the Group). Operating results of the operating segment are regularly reviewed by the Group’s chief operating decision maker to make decisions on the allocation of resources to the segment and to assess its performance for which discrete financial information is available.

#### 5. Critical accounting judgments and key sources of estimation uncertainty

The preparation of the consolidated financial statements in conformity with the Regulations and Taiwan-IFRSs requires management to make judgments, estimates and assumptions that affect the application of the accounting policies and the reported amount of assets, liabilities, income and expenses. Actual results may differ from these estimates. The estimates and underlying assumptions are reviewed on an ongoing basis. Revisions to accounting estimates are recognized in the period in which the estimates are revised and in the future periods affected.

There is no information involving critical judgments in applying the accounting policies in the consolidated financial statements.

Information about assumptions and estimation uncertainties that have a significant risk of resulting in a material adjustment within the next financial year is as follows:

## FLYTECH TECHNOLOGY CO., LTD. AND SUBSIDIARIES

### Notes to the Consolidated Financial Statements

(a) Valuation of inventory

Inventories are measured at the lower of cost or net realizable value, and the Group uses judgment and estimates to determine the net realizable value of inventory at each reporting date. Due to inventories are stated at the lower of cost or net realization value, the Group estimates the net realizable value of inventory, taking into account of obsolescence and unmarketable items at the reporting date, and then writes down the cost of inventories to net realizable value. The net realizable value of the inventory is mainly determined based on assumptions of future demand within a specific time horizon, which could result in significant adjustments. Refer to note 6(e) for more details of the valuation of inventories.

(b) Impairment of goodwill

The assessment of impairment of goodwill requires the Group to make subjective judgments to identify cash-generating units, allocate the goodwill to relevant cash-generating units, and estimate the recoverable amount of relevant cash-generating units. Any changes in these estimates based on changed economic conditions or business strategies could result in significant adjustments in future years. Refer to note 6(k) for more details of the impairment of goodwill.

#### 6. Significant account disclosures

(a) Cash and cash equivalents

|   | <b>December 31,<br/>2020</b> | <b>December 31,<br/>2019</b> |
|---|------------------------------|------------------------------|
| Cash on hand  | \$ 1,161                     | 1,297                        |
| Demand deposits and checking accounts                     | 2,408,712                    | 1,964,291                    |
| Time deposits with original maturities less than 3 months | 130,206                      | 245,262                      |
|   | <b>\$ 2,540,079</b>          | <b>2,210,850</b>             |

(b) Financial assets and liabilities at fair value through profit or loss

|  | <b>December 31,<br/>2020</b> | <b>December 31,<br/>2019</b> |
|--|------------------------------|------------------------------|
| Mandatorily measured at fair value through profit or loss: |                              |                              |
| Derivative instruments not used for hedging                |                              |                              |
| Foreign currency forward contracts                         | \$ 2,697                     | 120                          |
| Non-derivative financial assets                            |                              |                              |
| Convertible bonds  | 9,516                        | -                            |
|  | <b>\$ 12,213</b>             | <b>120</b>                   |
|  | <b>December 31,<br/>2020</b> | <b>December 31,<br/>2019</b> |
| Held-for trading financial liabilities:                    |                              |                              |
| Foreign currency forward contracts                         | <b>\$ (882)</b>              | <b>(417)</b>                 |

Refer to note 6(v) for the detail of the changes in fair value recognized in profit or loss.

**FLYTECH TECHNOLOGY CO., LTD. AND SUBSIDIARIES**

**Notes to the Consolidated Financial Statements**

The Group entered into derivative contracts to manage its foreign currency exchange risk resulting from its operating activities classified. The derivative financial instruments that did not conform to the criteria for hedge accounting were classified as financial assets and liabilities at fair value through profit or loss:

| <b>December 31, 2020</b>                                   |                        |        |                   |                        |
|--|------------------------|--------|-------------------|------------------------|
|  | <b>Contract amount</b> |        | <b>Sell / Buy</b> | <b>Maturity period</b> |
|  | <b>( in thousands)</b> |        |                   |                        |
| Financial assets—foreign currency forward contracts        | USD                    | 12,000 | USD/NTD           | 2021.1.11~2021.3.10    |
| Financial liabilities — foreign currency forward contracts | GBP                    | 1,410  | GBP/NTD           | 2021.2.26~2021.4.29    |
|  | USD                    | 350    | GBP/USD           | 2021.3.31~2021.6.30    |
| <b>December 31, 2019</b>                                   |                        |        |                   |                        |
|  | <b>Contract amount</b> |        | <b>Sell / Buy</b> | <b>Maturity period</b> |
|  | <b>( in thousands)</b> |        |                   |                        |
| Financial assets—foreign currency forward contracts        | GBP                    | 1,400  | GBP/NTD           | 2020.1.31~2020.2.27    |
| Financial liabilities—foreign currency forward contracts   | GBP                    | 650    | GBP/NTD           | 2020.1.31              |
|  | USD                    | 250    | GBP/USD           | 2020.3.20~2020.10.9    |

(c) Financial assets measured at amortised cost

|   | <b>December<br/>31, 2020</b> | <b>December<br/>31, 2019</b> |
|---|------------------------------|------------------------------|
| Time deposits with original maturities more than 3 months | <b>\$ 203,873</b>            | <b>304,795</b>               |
| Presented as:   |                              |                              |
| Current   | \$ 109,167                   | 287,575                      |
| Non-current   | 94,706                       | 17,220                       |
|   | <b>\$ 203,873</b>            | <b>304,795</b>               |

The Group intended to hold to maturity in order to receive the contractual cash flows and the contractual cash flows were solely payments of principal and interest on the principal outstanding.

**FLYTECH TECHNOLOGY CO., LTD. AND SUBSIDIARIES**

**Notes to the Consolidated Financial Statements**

(d) Notes and accounts receivable, and other receivables

|  | <b>December 31,<br/>2020</b> | <b>December 31,<br/>2019</b> |
|--|------------------------------|------------------------------|
| Notes receivable — from operating activities           | \$ 5,978                     | 5,871                        |
| Accounts receivable — measured as amortized cost       | 586,502                      | 862,315                      |
| Less: loss allowance                                   | (11,299)                     | (9,992)                      |
|  | 581,181                      | 858,194                      |
| Other receivables (classified as other current assets) | 3,645                        | 6,312                        |
|  | <b>\$ 584,826</b>            | <b>864,506</b>               |

The Group applies the simplified approach to provide for its expected credit losses, i.e. the use of lifetime expected loss provision for all receivables. To measure the expected credit losses, trade receivables have been based on shared credit risk characteristics and the days past due, as well as incorporated forward looking information. The loss allowance provision was determined as follows:

| <b>December 31, 2020</b> |                                  |  |   |
|--------------------------|----------------------------------|--|---|
|                          | <b>Gross carrying<br/>amount</b> | <b>Weighted-ave<br/>rage loss rate</b> | <b>Loss<br/>allowance<br/>provision</b> |
| Current                  | \$ 464,219                       | 0%~4.20%                               | 5,695                                   |
| Past due 0-30 days       | 112,315                          | 0%~7.17%                               | 1,718                                   |
| Past due 31-60 days      | 9,622                            | 0%~15.83%                              | 886                                     |
| Past due 61-180 days     | 1,593                            | 0%~100.00%                             | 205                                     |
| Past due over 180 days   | 4,731                            | 68.3%~100.00%                          | 2,795                                   |
|                          | <b>\$ 592,480</b>                |  | <b>11,299</b>                           |
| <b>December 31, 2019</b> |                                  |  |   |
|                          | <b>Gross carrying<br/>amount</b> | <b>Weighted-ave<br/>rage loss rate</b> | <b>Loss<br/>allowance<br/>provision</b> |
| Current                  | \$ 657,714                       | 0%~0.71%                               | 279                                     |
| Past due 0-30 days       | 148,948                          | 0%~4.05%                               | 1,319                                   |
| Past due 31-60 days      | 57,987                           | 0%~12.76%                              | 6,536                                   |
| Past due 61-180 days     | 2,301                            | 0%~100.00%                             | 622                                     |
| Past due over 180 days   | 1,236                            | 100.00%                                | 1,236                                   |
|                          | <b>\$ 868,186</b>                |  | <b>9,992</b>                            |

**FLYTECH TECHNOLOGY CO., LTD. AND SUBSIDIARIES**

**Notes to the Consolidated Financial Statements**

Movements of the loss allowance for notes and accounts receivable were as follows:

|   | <b>2020</b>      | <b>2019</b>  |
|---|------------------|--------------|
| Balance at January 1                    | \$ 9,992         | 12,049       |
| Impairment losses recognized (reversed) | 1,348            | (1,620)      |
| Write-off                               | (70)             | (454)        |
| Effect of exchange rate changes         | 29               | 17           |
| Balance at December 31                  | <b>\$ 11,299</b> | <b>9,992</b> |

The subsidiary of the Company, Adasys, entered into factoring contracts with a bank to sell parts of its accounts receivable without recourse. According to these contracts, the Group is not responsible for any risk of uncollectable accounts receivable, but only the risk of loss due to commercial disputes. The Group derecognized the above accounts receivable because it has transferred substantially all of the risks and rewards of their ownership, and it does not have any continuing involvement in them. The receivable from the financial institutions were recognized as other receivables upon the derecognition of those accounts receivables. At each reporting date, details of these contracts were as follows:

| <b>December 31, 2020</b> |                     |                 |                 |                    |                 |                     |
|--------------------------|---------------------|-----------------|-----------------|--------------------|-----------------|---------------------|
|                          | <b>Amount</b>       | <b>Amount</b>   | <b>Amount</b>   | <b>Recognized</b>  | <b>Range of</b> | <b>Significant</b>  |
| <b>Underwriting bank</b> | <b>Derecognized</b> | <b>advanced</b> | <b>advanced</b> | <b>in Other</b>    | <b>Interest</b> | <b>Transferring</b> |
|                          | <b>Amount</b>       | <b>(Unpaid)</b> | <b>(Paid)</b>   | <b>Receivables</b> | <b>Rate</b>     | <b>Terms</b>        |
| Deutsche Factoring Bank  | <b>\$ 6,725</b>     | <b>-</b>        | <b>6,056</b>    | <b>669</b>         | <b>2.75%</b>    | Nil                 |

| <b>December 31, 2019</b> |                     |                 |                 |                    |                 |                     |
|--------------------------|---------------------|-----------------|-----------------|--------------------|-----------------|---------------------|
|                          | <b>Amount</b>       | <b>Amount</b>   | <b>Amount</b>   | <b>Recognized</b>  | <b>Range of</b> | <b>Significant</b>  |
| <b>Underwriting bank</b> | <b>Derecognized</b> | <b>advanced</b> | <b>advanced</b> | <b>in Other</b>    | <b>Interest</b> | <b>Transferring</b> |
|                          | <b>Amount</b>       | <b>(Unpaid)</b> | <b>(Paid)</b>   | <b>Receivables</b> | <b>Rate</b>     | <b>Terms</b>        |
| Deutsche Factoring Bank  | <b>\$ 13,978</b>    | <b>-</b>        | <b>12,564</b>   | <b>1,414</b>       | <b>2.75%</b>    | Nil                 |

(e) Inventories

(i) The information of inventories was as follows:

|                 | <b>December 31,<br/>2020</b> | <b>December 31,<br/>2019</b> |
|-----------------|------------------------------|------------------------------|
| Raw materials   | \$ 299,641                   | 278,721                      |
| Work in process | 140,874                      | 141,249                      |
| Finished goods  | 74,189                       | 116,013                      |
| Merchandise     | 140,258                      | 176,246                      |
|                 | <b>\$ 654,962</b>            | <b>712,229</b>               |

**FLYTECH TECHNOLOGY CO., LTD. AND SUBSIDIARIES**

**Notes to the Consolidated Financial Statements**

(ii) The amounts of inventories recognized as cost of revenue were as follows:

|  | <u>2020</u>                | <u>2019</u>             |
|--|----------------------------|-------------------------|
| Costs of inventories sold                            | \$ 2,801,066               | 3,365,219               |
| Write-downs of inventories (Reversal of write-downs) | 16,628                     | (5,420)                 |
| Losses on scrap in inventories                       | 25,610                     | 33,460                  |
| Gain on physical inventories                         | (110)                      | (190)                   |
| Transfer for repairment costs                        | <u>39,035</u>              | <u>59,563</u>           |
|  | <u><u>\$ 2,882,229</u></u> | <u><u>3,452,632</u></u> |

(iii) Please refer to note 8 for a description of the Group's inventory collateralized for short-term borrowings.

(f) Investments accounted for using equity method

(i) Acquisition of subsidiaries – Qijie Electronics(Shenzhen) Co.,Ltd (“Qijie”)

In April, 2019, the group invested in Qijie Electronics(Shenzhen) Co., Ltd through Flyteh BVI CN with a cash investment of \$12,340, and obtained 40% of Qijie shares and significant influence over it. On October 1, 2019, the Group acquired additional 20% shares of Qijie with a cash investment of \$6,258, therefore obtain control over Qijie. Qijie engaged in the manufacturing and sales of low-end POS or Panel PC products in China.

1) The identifiable assets and liabilities assumed at the acquisition date are measured at fair value is as follows:

|   |              |                    |
|---|--------------|--------------------|
| Consideration transferred – cash  |              | \$ 6,258           |
| Add: Fair value of pre-existing interest in the acquiree                  |              | 10,708             |
| Non-controlling interest in the acquiree                                  |              | 11,311             |
| (proportionate share of the fair value of the identifiable net assets)    |              |                    |
| Less: Identifiable assets acquired and liabilities assumed at fair value: |              |                    |
| Cash and cash equivalents   | \$ 22,859    |                    |
| Account receivable  | 12           |                    |
| Inventories   | 3,401        |                    |
| Prepayments and other current assets                                      | 2,378        |                    |
| Right-of-use assets   | 1,112        |                    |
| Prepayments for equipment   | 2,160        |                    |
| Account payable   | (1,053)      |                    |
| Other payables  | (859)        |                    |
| Lease liabilities (current and non-current)                               | (1,141)      |                    |
| Othe current liabilities  | <u>(592)</u> | <u>28,277</u>      |
|   |              | <u><u>\$ -</u></u> |

## FLYTECH TECHNOLOGY CO., LTD. AND SUBSIDIARIES

### Notes to the Consolidated Financial Statements

2) Pro forma information

From the acquisition date to December 31, 2019, Qijie contributed a revenue of \$1,372 and a net loss of \$100. If the acquisition had occurred on January 1, 2019, the management estimates that the consolidated revenue in 2019 would have been \$5,331,648, and consolidated net income would have been \$736,351.

(g) Acquisitions of Non-Controlling Interests

In July 2020, the Group's subsidiary, Poindus System, acquired an additional 40% shares of Qijie for \$11,852 in cash, increasing its ownership from 60% to 100%.

The effects on the equity attributable to the shareholders of the Company arising from changes in ownership interests in Qijie:

|  | <b>Amount</b>   |
|--|-----------------|
| Carrying amount of non-controlling interest upon acquisition   | \$ 10,522       |
| Consideration paid to non-controlling interests  | (11,852)        |
| Capital surplus difference between the consideration and the carrying amount arising from the acquisition of subsidiary's shares | (1,330)         |
| The Group's ownership in Poindus System  | 49.31%          |
| Equity attributable to the shareholders of the Company   | <b>\$ (656)</b> |

In 2020, the Group's subsidiary, Fei Shiun Investment, acquired an additional 20% shares of iRuggy System for \$12,000 in cash, increasing its ownership from 80% to 100%.

The effects on the equity attributable to the shareholders of the Company arising from changes in ownership interests in iRuggy:

|  | <b>Amount</b>     |
|--|-------------------|
| Carrying amount of non-controlling interests upon acquisition  | \$ 5,054          |
| Consideration paid to non-controlling interests  | (12,000)          |
| Capital surplus difference between the consideration and the carrying amount arising from the acquisition of subsidiary's shares | (6,946)           |
| The Group's ownership in Fie Shiun Investment  | 100.00%           |
| Equity attributable to the shareholders of the Company   | <b>\$ (6,946)</b> |

(h) Subsidiaries that have material non-controlling interest

The material non-controlling interests of subsidiaries were as follows:

| Subsidiaries             | Principal place of<br>business<br>/Registration<br>country | The Percentage of<br>ownership and voting rights<br>held by non-controlling<br>interests |                      |
|--------------------------|--|--|----------------------|
|                          |  | December<br>31, 2020   | December<br>31, 2019 |
| Poindus System Co., Ltd. | Taiwan   | 50.69%   | 50.69%               |



## FLYTECH TECHNOLOGY CO., LTD. AND SUBSIDIARIES

### Notes to the Consolidated Financial Statements

The summarized financial information of Poindus System Co., Ltd. were as follows, the information was prepared in accordance with Taiwan-IFRSs. Intra-group transactions were not eliminated in this information:

|   | <b>December 31,<br/>2020</b> | <b>December 31,<br/>2019</b> |
|---|------------------------------|------------------------------|
| Current assets  | \$ 651,343                   | 586,651                      |
| Non-current assets  | 92,070                       | 114,275                      |
| Current liabilities   | (183,685)                    | (143,014)                    |
| Non-current liabilities   | (30,243)                     | (37,313)                     |
| Net assets  | <b><u>\$ 529,485</u></b>     | <b><u>520,599</u></b>        |
| The carrying amount of non-controlling interests                            | <b><u>\$ 268,423</u></b>     | <b><u>263,918</u></b>        |
|   |                              |                              |
|   | <b>2020</b>                  | <b>2019</b>                  |
| Net sales   | <b><u>\$ 1,019,316</u></b>   | <b><u>800,114</u></b>        |
| Net income (loss)   | \$ 33,652                    | (20,618)                     |
| Other comprehensive loss  | (288)                        | (3,814)                      |
| Total comprehensive income (loss)   | <b><u>\$ 33,364</u></b>      | <b><u>(24,432)</u></b>       |
| Net income (loss) attributable to non-controlling interests                 | <b><u>\$ 17,060</u></b>      | <b><u>(10,452)</u></b>       |
| Total comprehensive income (loss) attributable to non-controlling interests | <b><u>\$ (146)</u></b>       | <b><u>(1,934)</u></b>        |
|   |                              |                              |
| Cash flow from operating activities   | \$ 191,726                   | (18,448)                     |
| Cash flow from investing activities   | (60,230)                     | (7,332)                      |
| Cash flow from financing activities   | (32,917)                     | (31,610)                     |
| Effects of foreign exchange rate changes                                    | 553                          | 522                          |
| Net increase (decrease) in cash and cash equivalents                        | <b><u>\$ 99,132</u></b>      | <b><u>(56,868)</u></b>       |

(i) Property, plant and equipment

|                                 | Land                     | Buildings             | Machinery             | Mold<br>equipment     | Furniture<br>and<br>fixtures | Other<br>equipment   | Construction<br>in progress | Total                   |
|---------------------------------|--------------------------|-----------------------|-----------------------|-----------------------|------------------------------|----------------------|-----------------------------|-------------------------|
| Cost:                           |                          |                       |                       |                       |                              |                      |                             |                         |
| Balance at January 1, 2020      | \$ 319,238               | 773,325               | 297,499               | 481,697               | 93,704                       | 44,212               | -                           | 2,009,675               |
| Additions                       | -                        | 2,317                 | 4,790                 | 40,266                | 3,865                        | 6,353                | -                           | 57,591                  |
| Reclassification                | -                        | -                     | -                     | 2,018                 | -                            | 1,283                | -                           | 3,301                   |
| Disposals                       | -                        | -                     | (2,997)               | -                     | (106)                        | (2,787)              | -                           | (5,890)                 |
| Effect of exchange rate changes | -                        | (712)                 | (8)                   | 107                   | 55                           | 288                  | -                           | (270)                   |
| Balance at December 31, 2020    | <b><u>\$ 319,238</u></b> | <b><u>774,930</u></b> | <b><u>299,284</u></b> | <b><u>524,088</u></b> | <b><u>97,518</u></b>         | <b><u>49,349</u></b> | <b><u>-</u></b>             | <b><u>2,064,407</u></b> |
| Balance at January 1, 2019      | \$ 382,446               | 658,438               | 290,423               | 440,822               | 90,699                       | 42,994               | 41,887                      | 1,947,709               |
| Additions                       | -                        | -                     | 7,312                 | 37,610                | 5,122                        | 261                  | 11,027                      | 61,332                  |
| Reclassification                | (63,208)                 | 116,122               | -                     | 5,115                 | -                            | 1,595                | (52,914)                    | 6,710                   |
| Disposals                       | -                        | -                     | (238)                 | (1,788)               | (1,631)                      | (101)                | -                           | (3,758)                 |
| Effect of exchange rate changes | -                        | (1,235)               | 2                     | (62)                  | (486)                        | (537)                | -                           | (2,318)                 |
| Balance at December 31, 2019    | <b><u>\$ 319,238</u></b> | <b><u>773,325</u></b> | <b><u>297,499</u></b> | <b><u>481,697</u></b> | <b><u>93,704</u></b>         | <b><u>44,212</u></b> | <b><u>-</u></b>             | <b><u>2,009,675</u></b> |
| Accumulated depreciation:       |                          |                       |                       |                       |                              |                      |                             |                         |
| Balance at January 1, 2020      | \$ -                     | 163,265               | 206,002               | 394,255               | 72,593                       | 31,718               | -                           | 867,833                 |
| Depreciation                    | -                        | 18,215                | 20,577                | 42,893                | 6,764                        | 3,411                | -                           | 91,860                  |
| Disposals                       | -                        | -                     | (2,997)               | -                     | (106)                        | (2,207)              | -                           | (5,310)                 |
| Effect of exchange rate changes | -                        | 36                    | 16                    | 27                    | 95                           | 96                   | -                           | 270                     |
| Balance at December 31, 2020    | <b><u>\$ -</u></b>       | <b><u>181,516</u></b> | <b><u>223,598</u></b> | <b><u>437,175</u></b> | <b><u>79,346</u></b>         | <b><u>33,018</u></b> | <b><u>-</u></b>             | <b><u>954,653</u></b>   |

**FLYTECH TECHNOLOGY CO., LTD. AND SUBSIDIARIES**

**Notes to the Consolidated Financial Statements**

|                                 | <u>Land</u>       | <u>Buildings</u> | <u>Machinery</u> | <u>Mold<br/>equipment</u> | <u>Furniture<br/>and<br/>fixtures</u> | <u>Other<br/>equipment</u> | <u>Construction<br/>in progress</u> | <u>Total</u>     |
|---------------------------------|-------------------|------------------|------------------|---------------------------|---------------------------------------|----------------------------|-------------------------------------|------------------|
| Balance at January 1, 2019      | \$ -              | 148,393          | 184,108          | 351,540                   | 67,933                                | 28,588                     | -                                   | 780,562          |
| Depreciation                    | -                 | 15,597           | 22,140           | 44,379                    | 6,416                                 | 3,525                      | -                                   | 92,057           |
| Reclassification                | -                 | -                | -                | -                         | -                                     | (13)                       | -                                   | (13)             |
| Disposals                       | -                 | -                | (218)            | (1,664)                   | (1,384)                               | (98)                       | -                                   | (3,364)          |
| Effect of exchange rate changes | -                 | (725)            | (28)             | -                         | (372)                                 | (284)                      | -                                   | (1,409)          |
| Balance at December 31, 2019    | <u>\$ -</u>       | <u>163,265</u>   | <u>206,002</u>   | <u>394,255</u>            | <u>72,593</u>                         | <u>31,718</u>              | <u>-</u>                            | <u>867,833</u>   |
| Carrying amount:                |                   |                  |                  |                           |                                       |                            |                                     |                  |
| Balance at December 31, 2020    | <u>\$ 319,238</u> | <u>593,414</u>   | <u>75,686</u>    | <u>86,913</u>             | <u>18,172</u>                         | <u>16,331</u>              | <u>-</u>                            | <u>1,109,754</u> |
| Balance at December 31, 2019    | <u>\$ 319,238</u> | <u>610,060</u>   | <u>91,497</u>    | <u>87,442</u>             | <u>21,111</u>                         | <u>12,494</u>              | <u>-</u>                            | <u>1,141,842</u> |
| Balance at January 1, 2019      | <u>\$ 382,446</u> | <u>510,045</u>   | <u>106,315</u>   | <u>89,282</u>             | <u>22,766</u>                         | <u>14,406</u>              | <u>41,887</u>                       | <u>1,167,147</u> |

Please refer to note 8 for a description of the Group's equipment collateralized for short-term borrowings.

(j) Right-of-use assets

|  | <u>Buildings</u> | <u>Other<br/>equipment</u> | <u>Total</u>   |
|--|------------------|----------------------------|----------------|
| Cost:  |                  |                            |                |
| Balance at January 1, 2020                           | \$ 72,020        | 8,566                      | 80,586         |
| Additions  | 38,296           | 1,811                      | 40,107         |
| Write-off  | (11,071)         | (1,446)                    | (12,517)       |
| Effect of exchange rates changes                     | 559              | 86                         | 645            |
| Balance at December 31, 2020                         | <u>\$ 99,804</u> | <u>9,017</u>               | <u>108,821</u> |
| Balance at January 1, 2019                           | \$ 58,609        | 4,999                      | 63,608         |
| Acquition though business<br>combination( note 6(f)) | 1,599            | -                          | 1,599          |
| Additions  | 13,223           | 3,866                      | 17,089         |
| Write-off/lease modifications                        | (602)            | (217)                      | (819)          |
| Effect of exchange rate changes                      | (809)            | (82)                       | (891)          |
| Balance at December 31, 2019                         | <u>\$ 72,020</u> | <u>8,566</u>               | <u>80,586</u>  |
| Accumulated depreciation:                            |                  |                            |                |
| Balance at January 1, 2020                           | \$ 23,331        | 3,232                      | 26,563         |
| Depreciation   | 26,393           | 3,317                      | 29,710         |
| Write-off/lease modifications                        | (4,246)          | (1,446)                    | (5,692)        |
| Effect of exchange rates changes                     | 533              | 63                         | 596            |
| Balance at December 31, 2020                         | <u>\$ 46,011</u> | <u>5,166</u>               | <u>51,177</u>  |

**FLYTECH TECHNOLOGY CO., LTD. AND SUBSIDIARIES**

**Notes to the Consolidated Financial Statements**

|  | <b>Buildings</b>        | <b>Other<br/>equipment</b> | <b>Total</b>         |
|--|-------------------------|----------------------------|----------------------|
| Balance at January 1, 2019                           | \$ -                    | -                          | -                    |
| Acquisition through business combination (note 6(f)) | 487                     | -                          | 487                  |
| Depreciation   | 23,682                  | 3,487                      | 27,169               |
| Write-off lease modifications                        | (552)                   | (217)                      | (769)                |
| Effect of exchange rate changes                      | (286)                   | (38)                       | (324)                |
| Balance at December 31, 2019                         | <u><u>\$ 23,331</u></u> | <u><u>3,232</u></u>        | <u><u>26,563</u></u> |
| Carrying amount:                                     |                         |                            |                      |
| Balance at December 31, 2020                         | <u><u>\$ 53,793</u></u> | <u><u>3,851</u></u>        | <u><u>57,644</u></u> |
| Balance at December 31, 2019                         | <u><u>\$ 48,689</u></u> | <u><u>5,334</u></u>        | <u><u>54,023</u></u> |

(k) Intangible assets

|                                 | <b>Trademarks</b>       | <b>Patents<br/>and<br/>technology</b> | <b>Customer<br/>relationships</b> | <b>Goodwill</b>       | <b>Others</b>        | <b>Total</b>          |
|---------------------------------|-------------------------|---------------------------------------|-----------------------------------|-----------------------|----------------------|-----------------------|
| Cost:                           |                         |                                       |                                   |                       |                      |                       |
| Balance at January 1, 2020      | \$ 99,908               | 102,847                               | 320,021                           | 202,652               | 22,617               | 748,045               |
| Additions                       | -                       | -                                     | -                                 | -                     | 253                  | 253                   |
| Disposals                       | -                       | -                                     | -                                 | -                     | (5,511)              | (5,511)               |
| Effect of exchange rate changes | -                       | -                                     | -                                 | -                     | 21                   | 21                    |
| Balance at December 31, 2020    | <u><u>\$ 99,908</u></u> | <u><u>102,847</u></u>                 | <u><u>320,021</u></u>             | <u><u>202,652</u></u> | <u><u>17,380</u></u> | <u><u>742,808</u></u> |
| Balance at January 1, 2019      | \$ 99,908               | 102,847                               | 320,021                           | 202,652               | 42,817               | 768,245               |
| Additions                       | -                       | -                                     | -                                 | -                     | 3,538                | 3,538                 |
| Reclassification                | -                       | -                                     | -                                 | -                     | 1,023                | 1,023                 |
| Disposals                       | -                       | -                                     | -                                 | -                     | (24,740)             | (24,740)              |
| Effect of exchange rate changes | -                       | -                                     | -                                 | -                     | (21)                 | (21)                  |
| Balance at December 31, 2019    | <u><u>\$ 99,908</u></u> | <u><u>102,847</u></u>                 | <u><u>320,021</u></u>             | <u><u>202,652</u></u> | <u><u>22,617</u></u> | <u><u>748,045</u></u> |
| Accumulated amortization:       |                         |                                       |                                   |                       |                      |                       |
| Balance at January 1, 2020      | \$ 82,336               | 101,131                               | 191,374                           | 6,248                 | 16,889               | 397,978               |
| Amortization                    | 5,924                   | 1,716                                 | 37,744                            | -                     | 3,866                | 49,250                |
| Disposals                       | -                       | -                                     | -                                 | -                     | (5,511)              | (5,511)               |
| Effect of exchange rate         | -                       | -                                     | -                                 | -                     | 63                   | 63                    |
| Balance at December 31, 2020    | <u><u>\$ 88,260</u></u> | <u><u>102,847</u></u>                 | <u><u>229,118</u></u>             | <u><u>6,248</u></u>   | <u><u>15,307</u></u> | <u><u>441,780</u></u> |
| Balance at January 1, 2019      | \$ 64,304               | 80,562                                | 142,046                           | 6,248                 | 36,800               | 329,960               |
| Amortization                    | 18,032                  | 20,569                                | 49,328                            | -                     | 4,884                | 92,813                |
| Disposals                       | -                       | -                                     | -                                 | -                     | (24,740)             | (24,740)              |
| Effect of exchange rate changes | -                       | -                                     | -                                 | -                     | (55)                 | (55)                  |
| Balance at December 31, 2019    | <u><u>\$ 82,336</u></u> | <u><u>101,131</u></u>                 | <u><u>191,374</u></u>             | <u><u>6,248</u></u>   | <u><u>16,889</u></u> | <u><u>397,978</u></u> |
| Carrying amount:                |                         |                                       |                                   |                       |                      |                       |
| Balance at December 31, 2020    | <u><u>\$ 11,648</u></u> | <u><u>-</u></u>                       | <u><u>90,903</u></u>              | <u><u>196,404</u></u> | <u><u>2,073</u></u>  | <u><u>301,028</u></u> |
| Balance at December 31, 2019    | <u><u>\$ 17,572</u></u> | <u><u>1,716</u></u>                   | <u><u>128,647</u></u>             | <u><u>196,404</u></u> | <u><u>5,728</u></u>  | <u><u>350,067</u></u> |
| Balance at January 1, 2019      | <u><u>\$ 35,604</u></u> | <u><u>22,285</u></u>                  | <u><u>177,975</u></u>             | <u><u>196,404</u></u> | <u><u>6,017</u></u>  | <u><u>438,285</u></u> |

The amortization of intangible assets was included in the following line items of the consolidated statement of comprehensive income:

**FLYTECH TECHNOLOGY CO., LTD. AND SUBSIDIARIES**

**Notes to the Consolidated Financial Statements**

|                                   | <u>2020</u>             | <u>2019</u>          |
|-----------------------------------|-------------------------|----------------------|
| Cost of revenue                   | \$ 597                  | 690                  |
| Selling expenses                  | 81                      | 210                  |
| Administrative expenses           | 46,667                  | 89,505               |
| Research and development expenses | <u>1,905</u>            | <u>2,408</u>         |
|                                   | <b><u>\$ 49,250</u></b> | <b><u>92,813</u></b> |

The carrying amounts of goodwill resulted from business acquisition were allocated to the respective CGUs identified as the following subsidiaries as of December 31, 2020 and 2019:

|                 | <u>December 31,<br/>2020</u> | <u>December<br/>31, 2019</u> |
|-----------------|------------------------------|------------------------------|
| Box             | \$ 175,358                   | 175,358                      |
| Poindus Systems | 9,115                        | 9,115                        |
| Adasys          | <u>11,931</u>                | <u>11,931</u>                |
|                 | <b><u>\$ 196,404</u></b>     | <b><u>196,404</u></b>        |

Each CGU to which the goodwill is allocated represents the lowest level within the Group at which the goodwill is monitored for internal management purposes. As of December 31, 2020 and 2019, the recoverable amounts exceeded their carrying amounts based on the results of the impairment tests conducted by the Group. The recoverable amounts of a CGU were determined based on the value in use, and the related key assumptions were as follows:

|                             | <u>December 31, 2020</u> |               | <u>December 31, 2019</u> |               |
|-----------------------------|--------------------------|---------------|--------------------------|---------------|
|                             | <u>Box</u>               | <u>Adasys</u> | <u>Box</u>               | <u>Adasys</u> |
| Revenue growth rates        | 5%~26.52%                | -32%~24%      | 3%~19.77%                | 5%~54%        |
| Discount rates (before tax) | 13.19%                   | 13.08%        | 11.47 %                  | 12.97%        |

- (i) The cash flow projections were based on historical operating performance and future financial budgets, covering a period of 5 years, approved by management and estimated terminal values at the end of the 5-year period. Cash flows beyond that 5-year period have been extrapolated using 1%~2.8% growth rate.
- (ii) The discount rate used to determine value in use is based on the weighted average cost of capital.

**FLYTECH TECHNOLOGY CO., LTD. AND SUBSIDIARIES**

**Notes to the Consolidated Financial Statements**

(l) Short-term borrowings

The information of short-term borrowings were as follows:

|  | <u>December 31,<br/>2020</u> | <u>December 31,<br/>2019</u> |
|--|------------------------------|------------------------------|
| Secured bank loans   | \$ 806                       | 1,812                        |
| Unsecured loan from non-financial institution (short-term borrowings from individuals) | <u>7,004</u>                 | <u>6,718</u>                 |
|  | <u>\$ 7,810</u>              | <u>8,530</u>                 |
| Unused credit facilities   | <u>\$ 1,648,057</u>          | <u>1,703,957</u>             |
| Interest rate  | <u>3%~5.57%</u>              | <u>3%~7.11%</u>              |

For more information about the Group's exposure to interest rate risk and liquidity risk see note 6(v). Refer to Note 8 for detail on related assets pledged as collateral for secured loans.

(m) Lease liabilities

|             | <u>December 31,<br/>2020</u> | <u>December 31,<br/>2019</u> |
|-------------|------------------------------|------------------------------|
| Current     | <u>\$ 28,113</u>             | <u>23,506</u>                |
| Non-current | <u>\$ 33,770</u>             | <u>30,551</u>                |

For the maturity analysis, please refer to note 6(v).

The amounts recognized in profit or loss were as follows:

|   | <u>2020</u>     | <u>2019</u>  |
|---|-----------------|--------------|
| Interest on lease liabilities                   | <u>\$ 877</u>   | <u>1,431</u> |
| Expenses relating to short-term leases          | <u>\$ 3,264</u> | <u>3,196</u> |
| Expenses relating to leases of low-value assets | <u>\$ 264</u>   | <u>169</u>   |

The amounts recognized in the statement of cash flows for the Group was as follows:

|                               | <u>2020</u>      | <u>2019</u>   |
|-------------------------------|------------------|---------------|
| Total cash outflow for leases | <u>\$ 29,902</u> | <u>31,951</u> |

(i) Real estate leases

The Group leases buildings for its offices, factories and staff dormitory, the leases typically run for a period of one to five years. If the Group needed to renew the lease of contract amount at the end of contract term, and the Group to remeasure lease liabilities and right-of-use assets. Some leases include an option to renew the lease for an additional period of the same duration after the end of the contract term.

## FLYTECH TECHNOLOGY CO., LTD. AND SUBSIDIARIES

### Notes to the Consolidated Financial Statements

(ii) Other leases

The Group leases transportation equipments and other equipments, with lease terms of one to three years. These leases are short-term or low-value assets, the Group apply the exemption and not to recognize right-of-use assets and lease liabilities for these leases.

(n) Provision for warranties

|                                 | 2020             | 2019          |
|---------------------------------|------------------|---------------|
| Balance at January 1            | \$ 36,005        | 34,022        |
| Provisions (reversed) made      | (6)              | 2,403         |
| Amount utilized                 | (3,675)          | (2,419)       |
| Effect of exchange rate changes | (256)            | 1,999         |
| Balance at December 31          | <b>\$ 32,068</b> | <b>36,005</b> |

The provision for warranties is estimated based on historical warranty data associated with similar products. The Group expects to settle most of the warranty liability in one to three years from the date of the sale of the product.

(o) Employee benefits

(i) Defined benefit plans

The present value of defined benefit obligations and the fair value of plan assets were as follows:

|                                      | December 31,<br>2020 | December 31,<br>2019 |
|--------------------------------------|----------------------|----------------------|
| Present value of benefit obligations | \$ 83,954            | 87,392               |
| Fair value of plan assets            | (40,492)             | (42,811)             |
| Net defined benefit liabilities      | <b>\$ 43,462</b>     | <b>44,581</b>        |

The Group makes defined benefit plan contributions to the pension fund account at Bank of Taiwan that provides pension benefits for employees upon retirement. The plans (covered by the Labor Standards Law) entitle a retired employee to receive a payment based on years of service and average salary for the six months prior to the employee's retirement. The foreign subsidiary, Adasys, also has defined benefit pension plan based on its respective local laws and regulations.

1) Composition of plan assets

The pension fund (the "Fund") contributed by the Group is managed and administered by the Bureau of Labor Funds of the Ministry of Labor (the Bureau of Labor Funds). According to the Regulations for Revenues, Expenditures, Safeguard and Utilization of the Labor Retirement Fund, with regard to the utilization of the Fund, minimum earnings shall be no less than the earnings attainable from two-year time deposits with interest rates offered by local banks. Foreign subsidiaries with defined benefit plans make pension contributions to pension management institutions in accordance with their respective local regulations.

## FLYTECH TECHNOLOGY CO., LTD. AND SUBSIDIARIES

### Notes to the Consolidated Financial Statements

As of December 31, 2020 and 2019, the Company's labor pension fund account balance at Bank of Taiwan amounted to \$25,252 and \$28,983, respectively. Refer to the website of the Bureau of Labor Funds for information on the labor pension fund assets including the asset portfolio and yield of the fund.

As of December 31, 2020 and 2019, the foreign subsidiary, Adasys, made pension contributions amounting to \$15,240 and \$13,828, respectively, to the pension management institution based on the respective local laws and regulations.

2) Movements in present value of defined benefit obligations

|  | <b>2020</b>      | <b>2019</b>   |
|--|------------------|---------------|
| Defined benefit obligations at January 1                         | \$ 87,392        | 83,433        |
| Current service costs and interest expense                       | 1,074            | 1,583         |
| Remeasurement of net defined benefit liabilities:                |                  |               |
| – Actuarial losses arising from experience adjustments           | (118)            | 22            |
| – Actuarial losses arising from changes in financial assumptions | 3,037            | 6,213         |
| Benefits paid by plan – by the Company                           | (1,000)          | -             |
| Benefits paid by plan – by the plan assets                       | (8,039)          | (2,406)       |
| Effect of exchange rate changes                                  | 1,608            | (1,453)       |
| Defined benefit obligations at December 31                       | <b>\$ 83,954</b> | <b>87,392</b> |

3) Movements of fair value of plan assets

|   | <b>2020</b>      | <b>2019</b>   |
|---|------------------|---------------|
| Fair value of plan assets at January 1                      | \$ 42,811        | 41,083        |
| Interest income   | 460              | 617           |
| Remeasurement on net defined benefit liabilities:           |                  |               |
| –Return on plan assets (excluding current interest expense) | 456              | 611           |
| Contributions by plan participants                          | 3,932            | 3,565         |
| Benefits paid by the plan                                   | (8,039)          | (2,406)       |
| Effect of exchange rate changes                             | 872              | (659)         |
| Fair value of plan assets at December 31                    | <b>\$ 40,492</b> | <b>42,811</b> |

4) Changes in the effect of the asset ceiling

In 2020 and 2019, there was no effect of the asset ceiling.

**FLYTECH TECHNOLOGY CO., LTD. AND SUBSIDIARIES**  
**Notes to the Consolidated Financial Statements**

5) Expenses recognized in profit or loss

The expenses recognized in profit or losses were as follows:

|                      | <u>2020</u>   | <u>2019</u> |
|----------------------|---------------|-------------|
| Current service cost | \$ 386        | 331         |
| Net interest expense | 228           | 635         |
|                      | <u>\$ 614</u> | <u>966</u>  |
| Operating expenses   | <u>\$ 614</u> | <u>966</u>  |

6) Actuarial assumptions

The principal assumptions of the actuarial valuation were as follows:

|                              | <u>December 31,<br/>2020</u> | <u>December 31,<br/>2019</u> |
|------------------------------|------------------------------|------------------------------|
| Discount rate                | 0.75%~0.81%                  | 1%~1.17%                     |
| Future salary increases rate | 0%~2%                        | 0%~2%                        |

The weighted-average duration of the defined benefit plans is 12.2~17 years. The Group expects to make contribution of \$1,145 to the defined benefit plans in the year following December 31, 2020.

7) Sensitivity analysis

When calculating the present value of the defined benefit obligations, the Group uses judgments and estimations to determine the actuarial assumptions for each measurement date, including discount rates and future salary changes. Any changes in the actuarial assumptions may significantly impact the amount of the defined benefit obligations.

The following table summarizes the impact of a change in the assumptions on the present value of the defined benefit obligation:

|                             | <b>Impact on defined benefit<br/>obligation</b> |                       |
|-----------------------------|---|-----------------------|
|                             | <u>0.25% Increase</u>                           | <u>0.25% Decrease</u> |
| December 31, 2020           |   |                       |
| Discount rate               | (2,582)   | 2,422                 |
| Future salary increase rate | 867   | (763)                 |
| December 31, 2019           |   |                       |
| Discount rate               | (2,344)   | 2,559                 |
| Future salary increase rate | 958   | (837)                 |

Each sensitivity analysis considers the change in one assumption at a time, leaving the other assumptions unchanged. This approach shows the isolated effect of changing one individual assumption but does not take into account that some assumptions are related. The method used to carry out the sensitivity analysis is the same as the calculation of the net defined benefit liabilities recognized in the balance sheets. The method used to carry out the sensitivity analysis is the same as in the prior year.



## FLYTECH TECHNOLOGY CO., LTD. AND SUBSIDIARIES

### Notes to the Consolidated Financial Statements

(ii) Defined contribution plans

The Company and its domestic subsidiaries contribute monthly an amount equal to 6% of each employee's monthly wages to the employee's individual pension fund account at the Bureau of Labor Insurance in accordance with the provisions of the Labor Pension Act. Foreign subsidiaries make contributions in compliance with their respective local regulations. Under these defined contribution plans, the Group has no legal or constructive obligation to pay additional amounts after contributing a fixed amount.

The Group recognized expense of the defined contribution plans were as follow:

|                    | 2020             | 2019          |
|--------------------|------------------|---------------|
| Cost of revenue    | \$ 4,894         | 5,159         |
| Operating expenses | 19,073           | 18,600        |
|                    | <b>\$ 23,967</b> | <b>23,759</b> |

(p) Income taxes

|   | 2020              | 2019           |
|---|-------------------|----------------|
| Current income tax expense                        |                   |                |
| Current period                                    | \$ 135,845        | 174,644        |
| Adjustments for prior periods                     | (5,102)           | 478            |
|   | 130,743           | 175,122        |
| Deferred tax benefit                              |                   |                |
| Origination and reversal of temporary differences | 11,291            | (14,903)       |
| Income tax expense                                | <b>\$ 142,034</b> | <b>160,219</b> |

The Group's income tax benefits recognized in other comprehensive income were as follows:

|  | 2020          | 2019         |
|--|---------------|--------------|
| Items that will not be reclassified to profit or loss: |               |              |
| Remeasurement of defined benefit plans                 | <b>\$ 674</b> | <b>1,767</b> |

The reconciliation of the expected income tax expense calculated based on the R.O.C. statutory tax rate and the actual income tax expense reported in the consolidated statements of comprehensive income were as follows:

|  | 2020              | 2019           |
|--|-------------------|----------------|
| Income before income tax                               | <b>\$ 739,962</b> | <b>882,504</b> |
| Income tax using the Company's statutory tax rate      | \$ 147,993        | 176,501        |
| Effect of different tax rates in foreign jurisdictions | 9,928             | 18,588         |
| Tax-exempt income                                      | (3,674)           | (34,077)       |
| Investment tax credits                                 | (11,250)          | (872)          |
| Changes in unrecognized temporary differences          | 7,036             | 1,842          |
| Undistributed earnings additional tax                  | 4,078             | 3,720          |
| Alternative minimum tax                                | 24                | 25             |
| Prior-year adjustments                                 | (5,102)           | 478            |
| Others   | (6,999)           | (5,986)        |
|  | <b>\$ 142,034</b> | <b>160,219</b> |

## FLYTECH TECHNOLOGY CO., LTD. AND SUBSIDIARIES

### Notes to the Consolidated Financial Statements

(i) Deferred income tax assets and liabilities

As the Group is able to control the timing of the reversal of temporary differences associated with the loss on its investments in its subsidiaries, and concludes that the temporary differences will not reverse in the foreseeable future, such temporary differences were not recognized as deferred income tax assets.

1) Unrecognized deferred income tax assets

|   | December 31,<br>2020 | December 31,<br>2019 |
|---|----------------------|----------------------|
| Loss related to investments in subsidiaries | \$ 24,566            | 17,530               |

2) Recognized deferred income tax assets and liabilities

Deferred income tax assets:

|  | Defined<br>benefit plans | Inventory<br>provisions | Others        | Total         |
|--|--------------------------|-------------------------|---------------|---------------|
| <b>Balance at January 1, 2020</b>                  | \$ 11,283                | 13,230                  | 45,699        | 70,212        |
| Recognized in profit or loss                       | (897)                    | 2,388                   | (19,102)      | (17,611)      |
| Recognized in other comprehensive (loss)<br>income | 674                      | -                       | -             | 674           |
| Effect of exchange rate changes                    | (41)                     | 119                     | 470           | 548           |
| <b>Balance at December 31, 2020</b>                | <b>\$ 11,019</b>         | <b>15,737</b>           | <b>27,067</b> | <b>53,823</b> |
| <b>Balance at January 1, 2019</b>                  | \$ 10,200                | 14,525                  | 34,926        | 59,651        |
| Recognized in profit or loss                       | (429)                    | (1,171)                 | 11,129        | 9,529         |
| Recognized in other comprehensive (loss)<br>income | 1,767                    | -                       | -             | 1,767         |
| Effect of exchange rate changes                    | (255)                    | (124)                   | (356)         | (735)         |
| <b>Balance at December 31, 2019</b>                | <b>\$ 11,283</b>         | <b>13,230</b>           | <b>45,699</b> | <b>70,212</b> |

Deferred income tax liabilities:

|                                     | Unremitted<br>earnings<br>from<br>subsidiaries | Intangible<br>assets<br>acquired<br>through<br>business<br>combination | Others       | Total         |
|-------------------------------------|--|--|--------------|---------------|
| <b>Balance at January 1, 2020</b>   | \$ 30,435                                      | 29,918   | 1,327        | 61,680        |
| Recognized in profit or loss        | 1,814  | (8,562)  | 428          | (6,320)       |
| Effect of exchange rate changes     | -  | -  | (11)         | (11)          |
| <b>Balance at December 31, 2020</b> | <b>\$ 32,249</b>                               | <b>21,356</b>  | <b>1,744</b> | <b>55,349</b> |
| <b>Balance at January 1, 2019</b>   | \$ 27,155                                      | 38,480   | 1,408        | 67,043        |
| Recognized in profit or loss        | 3,280  | (8,562)  | (92)         | (5,374)       |
| Effect of exchange rate changes     | -  | -  | 11           | 11            |
| <b>Balance at December 31, 2019</b> | <b>\$ 30,435</b>                               | <b>29,918</b>  | <b>1,327</b> | <b>61,680</b> |

## FLYTECH TECHNOLOGY CO., LTD. AND SUBSIDIARIES

### Notes to the Consolidated Financial Statements

- (ii) The Company's income tax returns for the years through 2017 were examined and approved by the R.O.C income tax authorities excepts for 2016.

(q) Capital and other equity

(i) Common stock

As of December 31, 2020 and 2019, the Company's authorized shares of common stock consisted of 220,000 thousand shares and 180,000 thousand shares, respectively, with par value of \$10 (dollars) per share, both of which 143,062 thousand shares were issued and outstanding.

(ii) Capital surplus

|  | December 31,<br>2020 | December 31,<br>2019 |
|--|----------------------|----------------------|
| Premium derived from the issuance of shares in excess of par value:  |                      |                      |
| Premium on common stock issued of conversion of convertible bonds  | \$ 593,692           | 665,223              |
| Forfeited employee stock options   | 2,433                | 2,433                |
| Difference between the consideration and the carrying amounts arising from the acquisition or disposal of shares in subsidiaries | 982                  | 982                  |
| Changes in ownership interest in subsidiaries  | -                    | 5,594                |
| Gain on disposal of assets   | 15                   | 15                   |
|  | <b>\$ 597,122</b>    | <b>674,247</b>       |

Pursuant to the Company Act, any realized capital surplus is initially used to cover an accumulated deficit, and the balance, if any, could be transferred to common stock dividends or distributed as cash dividends based on the original shareholding ratio. Realized capital surplus includes the premium derived from the issuance of shares in excess of par value and donations from stockholders received by the Company. In accordance with the Regulations Governing the Offering and Issuance of Securities by Securities Issuers, distribution of stock dividends from capital surplus in any one year shall not exceed 10% of paid-in capital.

(iii) Retained earnings and dividend policy

The Company's Articles of Incorporation stipulate that at least 10% of annual net income after deducting an accumulated deficit, if any, must be retained as a legal reserve until such retention equals the amount of paid-in capital. In addition, a special reserve should be set aside in accordance with applicable laws and regulations. The remaining balance of annual net income, together with the unappropriated earnings from the previous years, should be distributed according to the proposal by the board of directors to be approved in the shareholders' meeting. Appropriation of earnings should not be less than 60% of the net income after deducting an accumulated deficit, legal reserve, and special reserve.

## FLYTECH TECHNOLOGY CO., LTD. AND SUBSIDIARIES

### Notes to the Consolidated Financial Statements

In accordance with Ruling No. 1010012865 issued by the Financial Supervisory Commission on April 6, 2012, a special reserve equal to the total amount of items that were accounted for as deductions from stockholders' equity was set aside from current and prior-year earnings. This special reserve shall revert to the retained earnings and be made available for distribution when the items that are accounted for as deductions from stockholders' equity are reversed in subsequent periods.

In view of the overall economic environment and the development of the industry, and in order to meet the Company's long-term financial planning and cash requirements of stockholders, the Company has adopted a stable dividend policy in which a cash dividend comprises at least 10% of total distribution of dividends.

The distribution of earnings for 2019 and 2018 had been approved in the meetings of shareholders held on June 10, 2020, and June 12, 2019, respectively. The relevant dividend distributions to shareholders were as follows:

|  | 2019                                   |                 | 2018                                   |                 |
|--|--|-----------------|--|-----------------|
|  | Dividends<br>per share<br>(in dollars) | Total<br>amount | Dividends<br>per share<br>(in dollars) | Total<br>amount |
| Dividends distributed to shareholders: |  |                 |  |                 |
| Cash                                   | \$ 4.00                                | <u>572,249</u>  | 4.50                                   | <u>643,780</u>  |

On June 10, 2020 and June 12, 2019, the Company's shareholders decided to distribute cash of \$0.5 dollars per share from capital surplus for both years. Total distributed cash dividend for 2019 and 2018 are \$4.5 and \$5.0 per share, respectively.

(iv) Other equity items (net after tax)

|  | Foreign<br>currency<br>translation<br>differences | Remeasureme<br>nt of defined<br>benefit plans | Total           |
|--|---|---|-----------------|
| Balance at January 1, 2020   | \$ (43,189)                                       | (6,213)                                       | (49,402)        |
| Exchange differences on subsidiaries accounted for using equity method (net of tax)      | (7,753)   | -   | (7,753)         |
| Remeasurement of defined benefit plans (net of tax)                                      | -   | 193   | 193             |
| Remeasurement of defined benefit plans on subsidiaries accounted for using equity method | -   | (977)   | (977)           |
| Balance at December 31, 2020   | <u>\$ (50,942)</u>                                | <u>(6,997)</u>                                | <u>(57,939)</u> |

**FLYTECH TECHNOLOGY CO., LTD. AND SUBSIDIARIES**

**Notes to the Consolidated Financial Statements**

|  | <b>Foreign currency<br/>translation<br/>differences</b> | <b>Remeasurement<br/>of defined<br/>benefit plans</b> | <b>Total</b>    |
|--|---|---|-----------------|
| Balance at January 1, 2019   | \$ (35,732)   | (4,612)   | (40,344)        |
| Exchange differences on subsidiaries accounted for using equity method (net of tax)      | (7,457)   | -   | (7,457)         |
| Remeasurement of defined benefit plans (net of tax)                                      | -   | 593   | 593             |
| Remeasurement of defined benefit plans on subsidiaries accounted for using equity method | -   | (2,194)   | (2,194)         |
| Balance at December 31, 2019   | <u>\$ (43,189)</u>                                      | <u>(6,213)</u>  | <u>(49,402)</u> |

(v) Non-controlling interests (net after tax)

|   | <b>2020</b>       | <b>2019</b>    |
|---|-------------------|----------------|
| Balance at January  | \$ 295,007        | 292,580        |
| Equity attributable to non-controlling interest:                        |                   |                |
| Net income  | 8,284             | (14,237)       |
| Cash dividends of subsidiaries distributed to non-controlling interests | (10,646)          | (10,646)       |
| Increase (decrease) in non-controlling interests                        | (17,339)          | 29,311         |
| Foreign currency translation differences                                | 564               | 255            |
| Remeasurement of defined benefit plans (net of tax)                     | (1,005)           | (2,256)        |
|   | <u>\$ 274,865</u> | <u>295,007</u> |

(r) Earnings per share (“EPS”)

(i) Basic EPS

|   | <b>2020</b>    | <b>2019</b> |
|---|----------------|-------------|
| Profit attributable to shareholders of the Company                    | \$ 589,644     | 736,522     |
| Weighted-average number of ordinary shares outstanding (in thousands) | 143,062        | 143,062     |
| Basic EPS (dollars)   | <u>\$ 4.12</u> | <u>5.15</u> |

**FLYTECH TECHNOLOGY CO., LTD. AND SUBSIDIARIES**

**Notes to the Consolidated Financial Statements**

(ii) Diluted EPS

|   | <b>2020</b>    | <b>2019</b> |
|---|----------------|-------------|
| Profit attributable to shareholders of the Company (diluted)  | \$ 589,644     | 736,522     |
| Weighted-average number of ordinary shares outstanding (in thousands)   | 143,062        | 143,062     |
| Effect of employee bonuses  | 1,115          | 1,295       |
| Weighted-average number of ordinary shares outstanding (in thousands) (including effect of dilutive potential common stock) | 144,177        | 144,357     |
| Diluted EPS (dollars)   | <b>\$ 4.09</b> | <b>5.10</b> |

(s) Revenue from contracts with customers

(i) Disaggregation of revenue

|                               | <b>2020</b>         | <b>2019</b>      |
|-------------------------------|---------------------|------------------|
| Primary geographical markets: |                     |                  |
| Domestic sales                | \$ 118,747          | 146,466          |
| Export:                       |                     |                  |
| Asia                          | 783,211             | 643,314          |
| America                       | 1,698,518           | 2,043,572        |
| Europe and Africa             | 1,832,485           | 2,497,120        |
|                               | \$ 4,314,214        | 5,184,006        |
|                               | <b>\$ 4,432,961</b> | <b>5,330,472</b> |
| Major products:               |                     |                  |
| Industrial computers          | \$ 3,591,909        | 4,403,277        |
| Peripherals                   | 738,707             | 804,321          |
| Others                        | 102,345             | 122,874          |
|                               | <b>\$ 4,432,961</b> | <b>5,330,472</b> |

(ii) Contract balances

|                                | <b>December 31, 2020</b> | <b>December 31, 2019</b> | <b>January 1, 2019</b> |
|--------------------------------|--------------------------|--------------------------|------------------------|
| Notes and accounts receivable  | \$ 592,480               | 868,186                  | 823,680                |
| Less: loss allowance           | (11,299)                 | (9,992)                  | (12,049)               |
| Total                          | <b>\$ 581,181</b>        | <b>858,194</b>           | <b>811,631</b>         |
| Contract liabilities — current | <b>\$ 60,946</b>         | <b>16,041</b>            | <b>19,167</b>          |

**FLYTECH TECHNOLOGY CO., LTD. AND SUBSIDIARIES**

**Notes to the Consolidated Financial Statements**

Please refer to note 6(d) for details on notes and accounts receivable and its loss allowance. The amount of revenue recognized for the year ended December 31, 2020 and 2019 that was included in the contract liability balance at the beginning of period were \$9,800 and \$15,689, respectively.

(t) Remuneration of employees and directors and supervisors

Pursuant to the Company's articles of incorporation, the Company shall distribute 3% to 15% of its profits in the current period as compensation to its employees and no more than 3% to its directors and supervisors. Nevertheless, the profits in the current period should be reserved for offsetting the accumulated deficit, if any, prior to distributing the compensation to the employees and directors and supervisors. The aforementioned compensation of employees could be distributed in the form of cash or stock to the employees of the Company's subsidiaries conforming to certain requirements.

For the year ended December 31, 2020 and 2019, the Company accrued the remuneration to its employees amounting to \$51,500 and \$77,000, respectively, and the remuneration to its directors amounting to \$3,500 for both years, which were calculated based on the net profits before tax of each period (excluding the remuneration to employees and directors), multiplied by the distribution ratio of remuneration to employees and directors under the Company's articles of incorporation, and recognized as cost of revenue and operating expenses. If the actual amounts differ from the estimated amounts, the differences shall be accounted as changes in accounting estimates and recognized as profit or loss in following year. The aforementioned accrued compensation of employees, directors and supervisors is the same as the amounts approved by the Board of Directors, and will be paid in cash. The related information would be available at the Market Observation Post System website.

(u) Non-operating income and loss

(i) Interest income

|                                   | <u>2020</u>      | <u>2019</u>   |
|-----------------------------------|------------------|---------------|
| Interest income from bank deposit | <u>\$ 12,032</u> | <u>19,384</u> |

(ii) Other income

|                  | <u>2020</u>      | <u>2019</u>  |
|------------------|------------------|--------------|
| Government grant | \$ 34,894        | -            |
| Others           | <u>9,021</u>     | <u>4,608</u> |
|                  | <u>\$ 43,915</u> | <u>4,608</u> |

**FLYTECH TECHNOLOGY CO., LTD. AND SUBSIDIARIES**

**Notes to the Consolidated Financial Statements**

(iii) Other gains and losses

|   | <b>2020</b>        | <b>2019</b>     |
|---|--------------------|-----------------|
| Disposal of investments loss  | \$ -               | (641)           |
| Foreign currency exchange loss  | (13,413)           | (46,076)        |
| Loss on financial assets and liabilities at fair value through profit or loss | (1,330)            | (1,147)         |
| Loss on disposal of property, plant and equipment                             | (63)               | (382)           |
| Others  | (362)              | (40)            |
|   | <b>\$ (15,168)</b> | <b>(48,286)</b> |

(iv) Finance costs

|   | <b>2020</b>     | <b>2019</b>  |
|---|-----------------|--------------|
| Interest expense from bank loans        | \$ 1,332        | 1,408        |
| Interest expense from lease liabilities | 877             | 1,431        |
|   | <b>\$ 2,209</b> | <b>2,839</b> |

(v) Financial instruments

(i) Categories of financial instruments

1) Financial assets

|  | <b>December 31,<br/>2020</b> | <b>December 31,<br/>2019</b> |
|--|------------------------------|------------------------------|
| Financial assets at fair value through profit or loss:                     |                              |                              |
| Financial assets mandatorily measured at fair value through profit or loss | <b>\$ 12,213</b>             | <b>120</b>                   |
| Financial assets measured at amortized cost:                               |                              |                              |
| Cash and cash equivalents  | \$ 2,540,079                 | 2,210,850                    |
| Financial assets measured at amortized cost                                | 203,873                      | 304,795                      |
| Notes and accounts receivable  | 581,181                      | 858,194                      |
| Other receivables(classified as other current assets)                      | 5,488                        | 9,839                        |
| Other financial assets – current   | 41,341                       | 224                          |
| Other financial assets – non-current                                       | 3,679                        | 3,460                        |
|  | <b>\$ 3,375,641</b>          | <b>3,387,362</b>             |



**FLYTECH TECHNOLOGY CO., LTD. AND SUBSIDIARIES**

**Notes to the Consolidated Financial Statements**

2) Financial liabilities

|   | <b>December 31,<br/>2020</b> | <b>December 31,<br/>2019</b> |
|---|------------------------------|------------------------------|
| Financial liabilities at fair value through profit or loss:                 |                              |                              |
| Financial liabilities held-for-trading – foreign currency forward contracts | \$ 882                       | 417                          |
| Financial liabilities measured at amortized cost:                           |                              |                              |
| Short term borrowings   | 7,810                        | 8,530                        |
| Notes and accounts payable  | 264,780                      | 394,221                      |
| Lease liabilities (including non-current)                                   | 61,883                       | 54,057                       |
| Other payables  | 244,448                      | 285,809                      |
|   | <b><u>\$ 578,921</u></b>     | <b><u>742,617</u></b>        |

(ii) Fair value valuation-financial instruments not measured at fair value

The Group considers that the carrying amounts of financial assets and financial liabilities measured at amortized cost approximate their fair values.

(iii) Financial instruments that are measured at fair value

The table below analyzes financial instruments that are measured at fair value subsequent to initial recognition, grouped into Levels 1 to 3 based on the degree to which the fair value is observable. The different levels have been defined as follows:

- 1) Level 1: quoted prices (unadjusted) in active markets for identified assets or liabilities.
- 2) Level 2: inputs other than quoted prices included within Level 1 that are observable for the asset or liability, either directly (i.e., as prices) or indirectly (i.e., derived from prices).
- 3) Level 3: inputs for the assets or liabilities that are not based on observable market data (unobservable inputs).

|   | <b>December 31, 2020</b>   |                   |                     |                     |                      |
|---|----------------------------|-------------------|---------------------|---------------------|----------------------|
|   | <b>Carrying<br/>Amount</b> | <b>Fair Value</b> |                     |                     | <b>Total</b>         |
|   |                            | <b>Level 1</b>    | <b>Level 2</b>      | <b>Level 3</b>      |                      |
| Financial assets mandatorily measured at fair value through profit or loss: |                            |                   |                     |                     |                      |
| Foreign currency forward contracts  | \$ 2,697                   | -                 | 2,697               | -                   | 2,697                |
| Convertible bonds   | 9,516                      | -                 | -                   | 9,516               | 9,516                |
|   | <b><u>\$ 12,213</u></b>    | <b><u>-</u></b>   | <b><u>2,697</u></b> | <b><u>9,516</u></b> | <b><u>12,213</u></b> |

**FLYTECH TECHNOLOGY CO., LTD. AND SUBSIDIARIES**

**Notes to the Consolidated Financial Statements**

|   |    | December 31, 2020 |            |            |         |            |
|---|----|-------------------|------------|------------|---------|------------|
|   |    | Carrying          | Fair Value |            |         |            |
|   |    | Amount            | Level 1    | Level 2    | Level 3 | Total      |
| Financial liabilities at fair value through profit or loss: |    |                   |            |            |         |            |
| Financial liabilities                                       |    |                   |            |            |         |            |
| held-for-trading– foreign                                   |    |                   |            |            |         |            |
| currency forward contracts                                  | \$ | <u>882</u>        | -          | <u>882</u> | -       | <u>882</u> |
|   |    | December 31, 2019 |            |            |         |            |
|   |    | Carrying          | Fair Value |            |         |            |
|   |    | Amount            | Level 1    | Level 2    | Level 3 | Total      |
| Financial assets at fair value through profit or loss:      |    |                   |            |            |         |            |
| Foreign currency forward                                    |    |                   |            |            |         |            |
| contracts   | \$ | <u>120</u>        | -          | <u>120</u> | -       | <u>120</u> |
| Financial liabilities                                       |    |                   |            |            |         |            |
| held-for-trading– foreign                                   |    |                   |            |            |         |            |
| currency forward contracts                                  | \$ | <u>417</u>        | -          | <u>417</u> | -       | <u>417</u> |

There were no transfers between fair value levels for the years ended December 31, 2020 and 2019.

Movement in financial assets included Level 3 fair value hierarchy:

|                        | 2020            | 2019     |
|------------------------|-----------------|----------|
| Balance at January 1   | \$ -            | -        |
| Additions              | 10,000          | -        |
| Recognized in loss     | (484)           | -        |
| Balance at December 31 | <u>\$ 9,516</u> | <u>-</u> |

(iv) Valuation techniques and assumptions used in fair value measurement

1) Non-derivative financial instruments

A financial instrument is regarded as being quoted in an active market if quoted prices are readily available. For unquoted equity instruments which cannot be transferred freely in public market, their fair values are determined by using the valuation techniques adopted by the Corporation based on the information from the Market Observation Post System, Taiwan Stock Exchange, etc., and calculated by using the BlackScholes Model. The Company uses the quoted market prices and the price-book ratios of similar publicly traded companies into consideration by using the market comparison approach. The estimates had been adjusted by the depreciation from lack of market liquidity.

2) Derivative financial instruments

The fair value of foreign currency forward contracts is computed individually by each contract using the valuation technique.

## FLYTECH TECHNOLOGY CO., LTD. AND SUBSIDIARIES

### Notes to the Consolidated Financial Statements

(w) Financial risk management

The Group is exposed to credit risk, liquidity risk, and market risk (including currency risk and interest rate risk). The Group has disclosed the information on exposure to the aforementioned risks, the Group's policies and procedures to measure and manage those risks, and the quantitative information below.

The Company's Board of Directors is responsible for developing and monitoring the Group's risk management policies. The Group's risk management policies are established to identify and analyze the risks faced by the Group, to set appropriate risk limits and controls, and to monitor adherence to the controls. Risk management policies and systems are reviewed regularly to reflect changes in market conditions and the Group's operations.

The Group's management monitors and reviews the financial activities in accordance with procedures required by relevant regulations and internal controls. Internal auditors undertake both regular and ad hoc reviews of risk management controls and procedures, the results of which are reported to the Company's Board of Directors.

(i) Credit risk

Credit risk is the risk of financial loss to the Group if a customer or counterparty of a financial instrument fails to meet its contractual obligations, and arises principally from the Group's cash and cash equivalents, receivables from customers, and other receivables. The maximum exposure to credit risk is equal to the carrying amount of the Group's financial assets.

The Group maintains cash and cash equivalents with reputable financial institutions. Therefore, the exposure related to potential default by those counter-parties is not considered significant.

As of December 31, 2020 and 2019, four clients accounted to a total of 39% and 58%, respectively, of the Group's notes and accounts receivable. In order to reduce credit risk, the Group has established a credit policy under which each customer is analyzed individually for creditworthiness for the purpose of setting the credit limit. Additionally, the Group continuously evaluates the credit quality of customers and utilizes insurance to minimize the credit risk.

For credit risk exposure and loss allowance of notes and accounts receivables, please refer to note 6(d). Cash, other receivable, financial assets measured at amortized cost and other financial assets are considered as low-credit-risk financial assets, and thus, the loss allowance are measured using 12-months ECL. As of December 31, 2020 and 2019, no loss allowance was provided for these financial assets after management's assessment.

## FLYTECH TECHNOLOGY CO., LTD. AND SUBSIDIARIES

### Notes to the Consolidated Financial Statements

(ii) Liquidity risk

Liquidity risk is the risk that the Group will encounter difficulty in settling its financial liabilities by delivering cash or other financial assets. The Group manages liquidity risk by monitoring regularly the current and mid- to long-term cash demand, and maintaining adequate cash and banking facilities. As of December 31, 2020 and 2019, the Group had unused credit facilities of \$1,648,057 and \$1,703,957, respectively.

The table below summarizes the maturity profile of the Group's financial liabilities based on contractual undiscounted payments.

|                                       | <u>Contractual<br/>cash flows</u> | <u>Within 1<br/>years</u> | <u>1-2 years</u> | <u>More than<br/>2 years</u> |
|---------------------------------------|-----------------------------------|---------------------------|------------------|------------------------------|
| <b>December 31, 2020</b>              |                                   |                           |                  |                              |
| Non-derivative financial liabilities: |                                   |                           |                  |                              |
| Short-term borrowings                 | \$ 7,810                          | 7,810                     | -                | -                            |
| Notes and accounts payable            | 264,780                           | 264,780                   | -                | -                            |
| Lease liabilities                     | 64,980                            | 29,073                    | 9,537            | 26,370                       |
| Other payables                        | 244,448                           | 244,448                   | -                | -                            |
|                                       | <u>\$ 582,018</u>                 | <u>546,111</u>            | <u>9,537</u>     | <u>26,370</u>                |
| Derivative financial instruments:     |                                   |                           |                  |                              |
| Foreign currency forward contracts:   |                                   |                           |                  |                              |
| Outflow                               | \$ 401,617                        | 401,617                   | -                | -                            |
| Inflow                                | (403,432)                         | (403,432)                 | -                | -                            |
|                                       | <u>\$ (1,815)</u>                 | <u>(1,815)</u>            | <u>-</u>         | <u>-</u>                     |
| <b>December 31, 2019</b>              |                                   |                           |                  |                              |
| Non-derivative financial liabilities: |                                   |                           |                  |                              |
| Short-term borrowings                 | \$ 8,530                          | 8,530                     | -                | -                            |
| Notes and accounts payable            | 394,221                           | 394,221                   | -                | -                            |
| Lease liabilities                     | 55,117                            | 24,242                    | 17,512           | 13,363                       |
| Other payables                        | 285,809                           | 285,809                   | -                | -                            |
|                                       | <u>\$ 743,677</u>                 | <u>712,802</u>            | <u>17,512</u>    | <u>13,363</u>                |
| Derivative financial instruments:     |                                   |                           |                  |                              |
| Foreign currency forward contracts:   |                                   |                           |                  |                              |
| Outflow                               | \$ 88,539                         | 88,539                    | -                | -                            |
| Inflow                                | (88,242)                          | (88,242)                  | -                | -                            |
|                                       | <u>\$ 297</u>                     | <u>297</u>                | <u>-</u>         | <u>-</u>                     |

The Group does not expect that the cash flows included in the maturity analysis would occur significantly earlier or at significantly different amounts.

## FLYTECH TECHNOLOGY CO., LTD. AND SUBSIDIARIES

### Notes to the Consolidated Financial Statements

(iii) Market risk

Market risk is the risk that changes in market prices, such as foreign exchange rates and interest rates, will affect the Group's income or the value of its financial instruments. The objective of market risk management is to manage and control market risk exposures within acceptable parameters, while optimizing the return.

The Group utilizes derivative financial instruments to manage market risk and the volatility of profit or loss. All such transactions are carried out within the guidelines set by the Company's Board of Directors.

1) Foreign currency risk

The Group's exposure to foreign currency risk arises from cash and cash equivalents, notes and accounts receivable(payables), other payables and other long-term liabilities. At the reporting date, the carrying amounts of the Group's significant monetary assets and liabilities denominated in a currency other than the respective functional currencies of Group entities were as follows (including the monetary items that have been eliminated in the accompanying consolidated financial statements):

(Amount in Thousands of Dollars)

**December 31, 2020**

|                              | <b>Foreign<br/>currency</b> | <b>Exchang<br/>e rate</b> | <b>NTD</b> | <b>Change in<br/>magnitude</b> | <b>Pre-tax<br/>effect on<br/>profit or loss</b> |
|------------------------------|-----------------------------|---------------------------|------------|--------------------------------|---|
| <u>Financial assets</u>      |                             |                           |            |                                |   |
| <u>Monetary items</u>        |                             |                           |            |                                |   |
| USD                          | \$ 26,177                   | 28.10                     | 735,574    | 1%                             | 7,356   |
| EUR                          | 1,697                       | 35.02                     | 59,429     | 1%                             | 594   |
| GBP                          | 3,536                       | 38.90                     | 137,550    | 1%                             | 1,376   |
| <u>Financial liabilities</u> |                             |                           |            |                                |   |
| <u>Monetary items</u>        |                             |                           |            |                                |   |
| USD                          | 5,580                       | 28.10                     | 156,798    | 1%                             | 1,568   |
| GBP                          | 412                         | 38.90                     | 16,027     | 1%                             | 160   |

**FLYTECH TECHNOLOGY CO., LTD. AND SUBSIDIARIES**

**Notes to the Consolidated Financial Statements**

| <b>December 31, 2019</b>     |                             |                          |            |                                |   |
|------------------------------|-----------------------------|--------------------------|------------|--------------------------------|---|
|                              | <b>Foreign<br/>currency</b> | <b>Exchange<br/>rate</b> | <b>NTD</b> | <b>Change in<br/>magnitude</b> | <b>Pre-tax effect<br/>on profit or<br/>loss</b> |
| <u>Financial assets</u>      |                             |                          |            |                                |   |
| <u>Monetary items</u>        |                             |                          |            |                                |   |
| USD                          | \$ 52,249                   | 29.98                    | 1,566,425  | 1%                             | 15,664  |
| RMB                          | 33,542                      | 4.31                     | 144,566    | 1%                             | 1,446   |
| EUR                          | 1,918                       | 33.59                    | 64,426     | 1%                             | 644   |
| GBP                          | 4,039                       | 39.36                    | 158,975    | 1%                             | 1,590   |
| <u>Financial liabilities</u> |                             |                          |            |                                |   |
| <u>Monetary items</u>        |                             |                          |            |                                |   |
| USD                          | 6,018                       | 29.98                    | 180,420    | 1%                             | 1,804   |
| GBP                          | 143                         | 39.36                    | 5,628      | 1%                             | 56  |

Due to the varieties of functional currency within the Group, the Group disclosed foreign exchange gain (loss) on monetary items in aggregate. For the years ended December 31, 2020 and 2019, the aggregate of realized and unrealized foreign exchange loss amounted to \$(13,413) and \$(46,076), respectively.

2) Interest rate risk

The Group's short-term borrowings carried floating interest rates, and the Group has not entered into interest rate swap contracts to convert floating interest rates to fixed interest rates. To manage the interest rate risk, the Group periodically assesses the interest rates of bank loans and maintains good relationships with financial institutions to obtain lower financing costs. The Group also strengthens the management of working capital to reduce the dependence on bank loans as well as the risk arising from fluctuation of interest rates.

The following sensitivity analysis is based on the risk exposure to floating-interest-rate liabilities on the reporting date. The sensitivity analysis assumes the liabilities recorded at the reporting date had been outstanding for the entire period. The change in interest rate reported to the key management in the Group is based on 100 basis points (1%), which is consistent with the assessment made by the key management in respect of the possible change in interest rate.

If the interest rate had been 100 basis points (1%) higher/lower with all other variables held constant, pre-tax income for the years ended December 31, 2020 and 2019, would have been \$78 and \$85, respectively, lower/higher, which mainly resulted from the borrowings with floating interest rates.

**FLYTECH TECHNOLOGY CO., LTD. AND SUBSIDIARIES**

**Notes to the Consolidated Financial Statements**

(x) Capital management

In consideration of industry dynamics and future development, as well as external environment factors, the Group maintains an optimal capital structure to enhance long-term shareholder value by managing its capital in a manner to ensure that it has sufficient and necessary financial resources to fund its working capital needs, dividend payments, and other business requirements for continuing operations and to reward shareholders and take into consideration the interests of other stakeholders.

(y) Investing and financing activities not affecting current cash flow

(i) For acquisition of right-of-use assets under operating lease for the year ended December 31, 2020, please refer to note 6(j).

(ii) Reconciliation of liabilities arising from financing activities were as follows:

|   | <b>January 1,<br/>2020</b> | <b>Cash flows</b>      | <b>Change in<br/>lease</b> | <b>Non-cash changes<br/>Foreign<br/>currency<br/>exchange<br/>movement</b> | <b>December 31,<br/>2020</b> |
|---|----------------------------|------------------------|----------------------------|--|------------------------------|
| Short-term borrowings                       | \$ 8,530                   | (1,024)                | -                          | 304  | 7,810                        |
| Lease liabilities                           | 54,057                     | (25,497)               | 33,160                     | 163  | 61,883                       |
| Total liabilities from financing activities | <b><u>\$ 62,587</u></b>    | <b><u>(26,521)</u></b> | <b><u>33,160</u></b>       | <b><u>467</u></b>  | <b><u>69,693</u></b>         |

|   | <b>January 1,<br/>2020</b> | <b>Cash flows</b>      | <b>Change in<br/>lease</b> | <b>Non-cash changes<br/>Foreign<br/>currency<br/>exchange<br/>movement</b> | <b>December 31,<br/>2019</b> |
|---|----------------------------|------------------------|----------------------------|--|------------------------------|
| Short-term borrowings                       | \$ 8,800                   | 52                     | -                          | (322)  | 8,530                        |
| Lease liabilities                           | 63,608                     | (27,155)               | 18,180                     | (576)  | 54,057                       |
| Total liabilities from financing activities | <b><u>\$ 72,408</u></b>    | <b><u>(27,103)</u></b> | <b><u>18,180</u></b>       | <b><u>(898)</u></b>  | <b><u>62,587</u></b>         |

**7. Related-party transactions**

(a) Significant related-party transactions: None.

(b) Compensation of key management personnel

|                              | <b>2020</b>             | <b>2019</b>          |
|------------------------------|-------------------------|----------------------|
| Short-term employee benefits | \$ 63,497               | 72,510               |
| Post-employment benefits     | 2,019                   | 4,077                |
|                              | <b><u>\$ 65,516</u></b> | <b><u>76,587</u></b> |

**FLYTECH TECHNOLOGY CO., LTD. AND SUBSIDIARIES**

**Notes to the Consolidated Financial Statements**

**8. Pledged assets**

The carrying amounts of assets pledged as collateral are detailed below:

| <b>Pledged assets</b>                              | <b>Pledged to secure</b>  | <b>December 31,<br/>2020</b> | <b>December 31,<br/>2019</b> |
|--|---|------------------------------|------------------------------|
| Inventory  | Credit lines of short-term borrowings                             | \$ 66,440                    | 74,277                       |
| Time deposits (classified as other current assets) | Guarantee deposit for custom duties and government grants project | 526                          | 224                          |
| Time deposits (classified as other current assets) | Guarantee for oversea sales project                               | 40,815                       | -                            |
| IT equipment (classified as office equipment)      | Secured bank loans  | 922                          | 1,132                        |
|  |   | <u>\$ 108,703</u>            | <u>75,633</u>                |

**9. Significant commitments and contingencies**

As of December 31, 2020 and 2019, the Group had outstanding stand-by letters of credit provided by banks totaling \$53,890 and \$0, respectively, for the purposes of oversea sales project.

**10. Significant losses due to major disasters: None**

**11. Significant subsequent events: None**

**12. Others**

Employee benefits, depreciation, and amortization expenses, categorized by function, were as follows:

| <b>By function</b> | <b>2020</b>          |                           |              | <b>2019</b>          |                           |              |
|--------------------|----------------------|---------------------------|--------------|----------------------|---------------------------|--------------|
|                    | <b>Cost of sales</b> | <b>Operating expenses</b> | <b>Total</b> | <b>Cost of sales</b> | <b>Operating expenses</b> | <b>Total</b> |
| <b>By item</b>     |                      |                           |              |                      |                           |              |
| Employee benefits: |                      |                           |              |                      |                           |              |
| Salaries           | 130,250              | 454,072                   | 584,322      | 149,865              | 491,114                   | 640,979      |
| Insurance          | 11,901               | 26,376                    | 38,277       | 13,066               | 27,000                    | 40,066       |
| Pension            | 4,894                | 19,687                    | 24,581       | 5,159                | 19,566                    | 24,725       |
| Others             | 5,247                | 12,649                    | 17,896       | 5,546                | 12,243                    | 17,789       |
| Depreciation       | 75,519               | 46,051                    | 121,570      | 76,119               | 43,107                    | 119,226      |
| Amortization       | 597                  | 48,653                    | 49,250       | 690                  | 92,123                    | 92,813       |



**FLYTECH TECHNOLOGY CO., LTD. AND SUBSIDIARIES**  
**Notes to the Consolidated Financial Statements**

**13. Additional disclosures**

(a) Information on significant transactions:

The following is the information on significant transactions required by the “Regulations Governing the Preparation of Financial Reports by Securities Issuers” for the Group:

(i) Financing provided to other parties:

(Amounts in Thousands of New Taiwan Dollars/Euro)

| No.<br>(Note 1) | Financing<br>Company | Counter-party                       | Financial<br>Statement<br>Account | Related<br>Parties | Maximum<br>Balance for<br>the Period | Ending<br>Balance   | Actual<br>Drawdown<br>Amounts | Interest<br>Rate | Nature of<br>Financing<br>(Note 2) | Transaction<br>Amounts | Reasons<br>for<br>Short-term<br>Financing | Allowance<br>for<br>Doubtful<br>Accounts | Collateral |       | Financing<br>Limits for<br>Each<br>Borrowing<br>Company<br>(Note 3) | Financing<br>Company's<br>Total Financing<br>Amount Limits<br>(Note 3) |
|-----------------|----------------------|-------------------------------------|-----------------------------------|--------------------|--------------------------------------|---------------------|-------------------------------|------------------|------------------------------------|------------------------|---|--|------------|-------|---|--|
|                 |                      |                                     |                                   |                    |                                      |                     |                               |                  |                                    |                        |   |  | Item       | Value |   |  |
| 1               | Poindus<br>Systems   | Adasys                              | Long term<br>other<br>receivables | Yes                | 22,802<br>(EUR650)                   | 22,763<br>(EUR 650) | 22,763<br>(EUR 650)           | 4%               | 1                                  | 108,779                |   | -  |            | -     | 52,949  | 211,794  |
| 1               | Poindus<br>Systems   | Poindus<br>Systems<br>UK<br>Limited | Long term<br>other<br>receivable  | Yes                | 31,416<br>(GBP 800)                  | 31,120<br>(GBP 800) | 31,120<br>(BGP 800)           | 1%               | 1                                  | 17,031                 |   | -  |            | -     | 17,031  | 211,794  |

Note 1: Represents the Company.

1. "0" represents the Company
2. Subsidiaries are numbered from "1"

Note 2: Nature of financing

1. Business transaction purpose
2. Short-term financing

Note 3: The individual financing amounts shall not exceed the lower amounts of transaction amounts of the most recent year and 10% of the most recent audited or reviewed net worth of Poindus Systems. The aggregate financing amount shall not exceed 40% of the most recent audited or reviewed net worth of Poindus Systems.

(ii) Guarantees and endorsements provided to other parties:

(Amount in Thousands of New Taiwan Dollars)

| No. | Endorsemen<br>Guarantee<br>Provider | Guaranteed Party               |                                       | Limits on<br>Endorsement/<br>Guarantee<br>Amount<br>Provided to<br>Each<br>Guaranteed<br>Party<br>(Note 3) | Maximum<br>Balance<br>for the Period | Ending<br>Balance | Amount<br>Actually<br>Drawn | Amount of<br>Endorsement/<br>Guarantee<br>Collateralized<br>by Properties | Ratio of<br>Accumulated<br>Endorsement/<br>Guarantee to<br>Net Equity per<br>Latest Financial<br>Statements | Maximum<br>Endorsement/<br>Guarantee<br>Amount<br>Allowable<br>(Note 3) | Guarantee<br>Provided by<br>Parent<br>Company | Guarantee<br>Provided by<br>A Subsidiary | Guarantee<br>Provided to<br>Subsidiaries in<br>Mainland<br>China |
|-----|-------------------------------------|--------------------------------|---------------------------------------|--|--------------------------------------|-------------------|-----------------------------|---|---|---|---|--|--|
|     |                                     | Name                           | Nature of<br>Relationship<br>(Note 2) |  |                                      |                   |                             |   |   |   |   |  |  |
| 0   | The<br>Company                      | Box<br>Technologies<br>limited | 2                                     | 866,834  | 80,000                               | 80,000            | -                           | -   | 1.85%   | 2,167,085   | Y   | N  | N  |

Note 1: The numbers filled in for the endorsements/guarantees provided by the Company or subsidiaries are as follows:

1. The Company is "0"
2. The subsidiaries are numbered in order starting from "1"

Note 2: Relationship between the endorser/guarantor and the party being endorsed/guaranteed is classified as "2" the endorser/guarantor which the parent company owns directly more than 50% of its voting shares.

Note 3: The Company provides guarantee to a subsidiary which the parent company owns directly 100% of its voting shares; the limit on endorsement or guarantee provided by the Company to a single party should not exceed 20% of its net worth. The total amount of endorsement or guarantee provided by the Company should not exceed 50% of its net worth.

(iii) Marketable securities held at the reporting date (excluding investments in subsidiaries, associates, and jointly controlled entities):

(Amounts in Thousands of New Taiwan Dollars and shares)

| Investing<br>Company | Marketable<br>Securities<br>Type and Name           | Relationship<br>with the<br>Securities<br>Issuer | Financial<br>Statement<br>Account  | Ending Balance      |                   |                               |            | Maximum Percentage<br>of Ownership during<br>2020 |                               | Note |
|----------------------|---|--|--|---------------------|-------------------|-------------------------------|------------|---|-------------------------------|------|
|                      |   |  |  | Number of<br>Shares | Carrying<br>Value | Percentage<br>of<br>Ownership | Fair value | Number of<br>Shares                               | Percentage<br>of<br>Ownership |      |
| The Company          | Convertible bond;<br>Nextronics<br>engineering core | -  | Financial assets<br>at fair value<br>through profit or<br>loss – current | 0.1                 | 9,516             | -                             | 9,516      | 0.1   | -                             | -    |
| Flytech CN<br>BVI    | Convertible bond;<br>Astra cloud<br>holdings        | -  | Financial assets<br>at fair value<br>through profit or<br>loss – current | -                   | -                 | -                             | -          | -   | -                             | -    |

**FLYTECH TECHNOLOGY CO., LTD. AND SUBSIDIARIES**  
**Notes to the Consolidated Financial Statements**

- (iv) Marketable securities for which the accumulated purchase or sale amounts for the year exceed \$300 million or 20% of the paid-in capital: None
- (v) Acquisition of real estate which exceeds \$300 million or 20% of the paid-in capital: None
- (vi) Disposal of real estate which exceeds \$300 million or 20% of the paid-in capital: None
- (vii) Total purchases from and sales to related parties which exceed \$100 million or 20% of the paid-in capital:

(Amounts in Thousands of New Taiwan Dollars)

| Company Name | Related Party   | Relationship | Transaction Details |                 |                               |               | Transactions with Terms Different from Others |               | Notes/Accounts Receivable (Payable) |  | Note |
|--------------|-----------------|--------------|---------------------|-----------------|-------------------------------|---------------|---|---------------|-------------------------------------|--|------|
|              |                 |              | Purchases/ (Sales)  | Amount (Note 3) | % of Total Purchases/ (Sales) | Payment Terms | Unit Price                                    | Payment Terms | Ending Balance                      | % of Total Notes/Accounts Receivable (Payable) |      |
| The Company  | Poindus Systems | Subsidiary   | (Sales)             | 304,931         | 6.88%                         | EM 60         | (Note 1)                                      | (Note 2)      | 45,379                              | 7.81%  |      |
| The Company  | Box UK          | Subsidiary   | (Sales)             | 202,313         | 4.56%                         | EM 180        | (Note 1)                                      | (Note 2)      | 80,097                              | 13.78%   |      |

Note 1: The selling prices with related parties are influenced by the economic environment and market competitiveness in each regions.  
Note 2: The trade terms of sales with related parties are EOM 60~180 days, and the trade terms with third parties are OA 30~75 days.  
Note 3: The intercompany transactions are disclosed only for the amounts of sales; the corresponding purchases are not disclosed.

- (viii) Receivables from related parties which exceed \$100 million or 20% of the paid-in capital: None

(Amounts in Thousands of New Taiwan Dollars)

- (ix) Transactions in derivative instruments: Refer to note 6(b)
- (x) Business relationships and significant intercompany transactions:

(Amounts in Thousands of New Taiwan Dollars)

| Number (Note 1) | Company Name   | Counter-party  | Relationship | Transaction Details |         |                   | Percentage of Consolidated Total Revenues or Total Assets (Note 3) |
|-----------------|----------------|----------------|--------------|---------------------|---------|-------------------|--|
|                 |                |                |              | Account (Note 2)    | Amount  | Transaction Terms |  |
| 0               | The Company    | Box UK         | Subsidiary   | Sales               | 202,313 | EM 180            | 4.60%  |
| 0               | The Company    | Poindus System | Subsidiary   | Sales               | 304,931 | EM 60             | 6.90%  |
| 0               | The Company    | Flytech CN     | Subsidiary   | Sales               | 69,703  | EM 90             | 1.60%  |
| 0               | The Company    | Box UK         | Subsidiary   | Accounts receivable | 80,097  | EM 180            | 1.40%  |
| 1               | Poindus System | Adasys         | Subsidiary   | Sales               | 108,779 | 90~150 days       | 2.50%  |

Note 1: Parties to intercompany transactions are identified and numbered as follows:

1. "0" represents the Company.
2. Subsidiaries are numbered from "1"

Note 2: Intercompany relationships and significant intercompany transactions are disclosed only for the amounts that exceed 1% of consolidated revenue or total assets. The corresponding purchases and accounts payables are not disclosed.

Note 3: Based on the transaction amount divided by consolidated revenue or total assets.

Note 4: The above intercompany transactions have been eliminated when preparing the consolidated financial statements.

- (b) Information on investees:

The following is the information on investees for the years ended December 31, 2020 (excluding information on investees in Mainland China):

(Amounts in Thousands of shares/ foreign currency and New Taiwan Dollars)

| Investor    | Investee        | Location               | Main Businesses and Products    | Original Investment Amount |                   | Balance as of December 31, 2020 |                         |                | Maximum Percentage of Ownership during 2019 |                         | Net Income (Loss) of the Investee | Investment Income (Loss) (note 3) | Note (note 1) |
|-------------|-----------------|------------------------|---------------------------------|----------------------------|-------------------|---------------------------------|-------------------------|----------------|---|-------------------------|-----------------------------------|-----------------------------------|---------------|
|             |                 |                        |                                 | December 31, 2020          | December 31, 2019 | Shares                          | Percentage of Ownership | Carrying value | Shares                                      | Percentage of Ownership |                                   |                                   |               |
| The Company | Flytech USA BVI | British Virgin Islands | Investment and holding activity | 38,652                     | 38,652            | 100                             | 100.00%                 | 17,227         | 100   | 100.00%                 | (224)                             | (224)                             |               |
| The Company | Flytech HK BVI  | British Virgin Islands | Investment and holding activity | 10,392                     | 10,392            | 50                              | 100.00%                 | 133,517        | 50  | 100.00%                 | 5,249                             | 5,249                             |               |
| The Company | Flytech CN BVI  | British Virgin Islands | Investment and holding activity | 90,601                     | 90,601            | 200                             | 100.00%                 | 126,805        | 350   | 100.00%                 | 4,047                             | 4,047                             |               |

**FLYTECH TECHNOLOGY CO., LTD. AND SUBSIDIARIES**

**Notes to the Consolidated Financial Statements**

| Investor             | Investee             | Location       | Main Businesses and Products   | Original Investment Amount |                       | Balance as of December 31, 2020 |                         |                        | Maximum Percentage of Ownership during 2019 |                         | Net Income (Loss) of the Investee | Investment Income (Loss) (note 3) | Note (note 1) |
|----------------------|----------------------|----------------|--|----------------------------|-----------------------|---------------------------------|-------------------------|------------------------|---|-------------------------|-----------------------------------|-----------------------------------|---------------|
|                      |                      |                |  | December 31, 2020          | December 31, 2019     | Shares                          | Percentage of Ownership | Carrying value         | Shares                                      | Percentage of Ownership |                                   |                                   |               |
| The Company          | Fei Shiun Investment | Taiwan         | Investment and holding activity  | 428,000                    | 428,000               | 19,000                          | 100.00%                 | 374,689                | 19,000                                      | 100.00%                 | (3,535)                           | (3,535)                           |               |
| The Company          | Box Holdings         | United Kingdom | Investment and holding activity  | 511,307                    | 511,307               | 4                               | 100.00%                 | 434,484                | 4   | 100.00%                 | 9,406                             | (20,579)                          |               |
| Flytech USA BVI      | Flytech USA          | USA            | Sale of computers and peripherals  | 36,358<br>(USD1,072)       | 36,358<br>(USD1,072)  | 700                             | 100.00%                 | 16,262<br>(USD579)     | 700   | 100.00%                 | (224)<br>(USD8)                   | -                                 |               |
| Flytech HK BVI       | Flytech HK           | Hong Kong      | Sale of computers and peripherals  | 10,433<br>(USD298)         | 10,433<br>(USD298)    | 1,000                           | 100.00%                 | 135,135<br>(USD4,809)  | 1,000                                       | 100.00%                 | 5,249<br>(USD178)                 | -                                 |               |
| Flytech HK           | iSAPPOS              | Hong Kong      | Sale of computers and peripherals  | 31,690<br>(HKD7,500)       | 31,690<br>(HKD7,500)  | (Note 2)                        | 100.00%                 | 2,486<br>(HKD677)      | (Note 2)                                    | 100.00%                 | (36)<br>(HKD9)                    | -                                 |               |
| Fei Shiun Investment | Berry AI             | Taiwan         | Operating software design and data processing services, and integrating software and hardware services | 42,000                     | 42,000                | 4,200                           | 70.00%                  | 15,030                 | 4,200                                       | 70.00%                  | (27,245)                          | -                                 |               |
| Fei Shiun Investment | iRUGGY System        | Taiwan         | Sale of computers and peripherals  | 60,000                     | 48,000                | 6,000                           | 100.00%                 | 25,976                 | 6,000                                       | 100.00%                 | 167                               | -                                 |               |
| Fei Shiun Investment | Poindus Systems      | Taiwan         | Sale of computers and peripherals  | 308,070                    | 308,070               | 10,354                          | 49.31%                  | 270,178                | 10,354                                      | 49.31%                  | 37,518                            | -                                 |               |
| Poindus Systems      | Poindus Investment   | Taiwan         | Investment and holding activity  | 4,100                      | 4,100                 | (Note 2)                        | 100.00%                 | 752                    | (Note 2)                                    | 100.00%                 | (95)                              | -                                 |               |
| Poindus Systems      | Adasys               | Germany        | Sale of computers and peripherals  | 57,712<br>(EUR 1,730)      | 57,712<br>(EUR 1,730) | 0.002                           | 100.00%                 | 13,003                 | (Note 1)                                    | 100.00%                 | 2,537                             | -                                 |               |
| Poindus Systems      | Poindus UK           | United Kingdom | Sale of computers and peripherals  | 14,297<br>(GBP 300)        | 14,297<br>(GBP 300)   | 300                             | 100.00%                 | (10,450)               | 300   | 100.00%                 | (3,735)                           | -                                 |               |
| Poindus Investment   | Poindus GmbH         | Germany        | Sale of computers and peripherals  | 1,721<br>(EUR 40)          | 1,721<br>(EUR 40)     | (Note 2)                        | 100.00%                 | 303                    | (Note 2)                                    | 100.00%                 | (95)                              | -                                 |               |
| Box Holdings         | Box UK               | United Kingdom | Sale of computers and peripherals  | 472<br>(GBP 10)            | 472<br>(GBP 10)       | 10                              | 100.00%                 | 243,133<br>(GBP 6,250) | 10  | 100.00%                 | 9,795<br>(GBP 257)                | -                                 |               |
| Box Holdings         | Box Nordic           | Sweden         | Sale of computers and peripherals  | 2,330<br>(GBP 49)          | 2,330<br>(GBP 49)     | 5                               | 100.00%                 | 7,928<br>(GBP 204)     | 5   | 100.00%                 | 729<br>(GBP 19)                   | -                                 |               |

Note 1: The intercompany transactions have been eliminated when preparing the consolidated financial statements.

Note 2: There were no shares as the company is a limited liability company.

Note 3: Included the movement in unrealized gross profit or loss.

(c) Information on investments in Mainland China:

(i) Information on investment in Mainland China

(Amounts in Thousands of New Taiwan Dollars and US Dollars)

| Investee   | Main Businesses and Products      | Total Amount of Paid-in Capital | Method of Investment | Accumulated Outflow of Investment from Taiwan as of January 1, 2020 | Investment Flows      |        | Accumulated Outflow of Investment from Taiwan as of December 31, 2020 | Net Income (Loss) of Investee | % of Ownership of Direct and Indirect Investment | Maximum Percentage of Ownership during 2017 |                         | Investment Income (Loss) (Note 2) | Carrying Value as of December 31, 2020 | Accumulated Inward Remittance of Earnings as of December 31, 2020 |
|------------|-----------------------------------|---------------------------------|----------------------|---|-----------------------|--------|---|-------------------------------|--|---|-------------------------|-----------------------------------|--|---|
|            |                                   |                                 |                      |   | Outflow               | Inflow |   |                               |  | Shares (in thousands)                       | Percentage of Ownership |                                   |  |   |
| Flytech CN | Sale of computers and peripherals | 69,089<br>(USD 2,000)           | (Note 1)             | 69,089<br>(USD 2,000)   | -                     | -      | 69,089<br>(USD 2,000)   | 7,800<br>(USD 262)            | 100.00%  | (Note 3)                                    | 100.00%                 | 7,800<br>(USD 262)                | 116,225<br>(USD 3,994)                 | -   |
| Qijie      | Sale of computers and peripherals | 30,850<br>(USD 1,000)           | (Note 2)             | 6,258<br>(USD 200)  | 29,630<br>(USD 1,000) | -      | 35,888<br>(USD 1,200)   | (2,772)                       | 49.31%   | (Note 3)                                    | 60.00%                  | (2,275)                           | 25,918                                 | -   |

Note 1: Indirect investment in Mainland China through a holding company, Flytech CN BVI, established in a third country

Note 2: (1) Flytech CN BVI reinvested the amount of USD 392 thousand it incurred from the liquidation of Flytech BI, together with its own funds, and acquired 40% ownership of Qijie.

(2) In 2019, the Company acquired an additional 20% share ownership of Qijie through Flytech CN BVI.

(3) The 60% and 40% ownership of Flytech CN BVI and the third parties amounting to USD600 and USD400, respectively, in Qijie were acquired by Poindus Systems in 2020, resulting in Poindus System to fully own Qijie.

(ii) Limits on investment in Mainland China

(Amounts in Thousands of New Taiwan Dollars and US Dollars)

| Accumulated investment in Mainland China as of December 31, 2020 | Investment amount authorized by Ministry of Economic Affairs Investment Commission | Upper Limit on Investment |
|--|--|---------------------------|
| 120,397<br>(USD 3,700)   | 121,617<br>(USD 4,100)   | 2,600,502                 |

(iii) Significant transactions with the investee in Mainland China: None

**FLYTECH TECHNOLOGY CO., LTD. AND SUBSIDIARIES**

**Notes to the Consolidated Financial Statements**

(d) Major shareholders:

| Shareholder's Name | Shareholding | Shares     | Percentage |
|--------------------|--------------|------------|------------|
| Lam Tai Seng       |              | 16,423,263 | 11.47%     |
| Wang Wei Wei       |              | 11,040,443 | 7.71%      |

**14. Segment information**

(a) General information

The three current reportable segments of the Group are: (i) the domestic sales segment, (ii) the European sales segment and (iii) the Poindus Systems. The domestic sales segment engages mainly in the development, design, manufacture, sales and provide after sale service of the products; the European sales segment engages mainly in the sales and provide after sales service of the products in Europe; and the Poindus Systems engages mainly in the sales and provide after sale service for Poindus Systems' products globally.

The classification of the segments is based on the products, services or geographical location of each respective segment. Each segment manages and caters to the different needs of their customers, as well as needs different marketing strategies, and thus, should be managed separately.

The Group uses income (loss) before income tax as the measurement for each segment's profit and the basis of resource allocation and performance assessment. The reporting amount is consistent with the report used by chief operating decision maker. Sales and transfers among reportable segments are recorded in line with sales to third-party customers.

The Group's operating segment information and reconciliation are as follows:

|                                     | 2020                     |                          |                    |                 |                                    |                  |
|-------------------------------------|--------------------------|--------------------------|--------------------|-----------------|------------------------------------|------------------|
|                                     | Domestic sale<br>segment | European<br>sale segment | Poindus<br>Systems | Others          | Adjustments<br>and<br>eliminations | Total            |
| Revenues from external customers\$  | 2,665,483                | 571,984                  | 1,007,585          | 187,909         | -                                  | 4,432,961        |
| Intra-group revenue                 | 613,249                  | 6,307                    | 11,731             | 13,769          | (645,056)                          | -                |
| Total segment revenue               | <b>\$ 3,278,732</b>      | <b>578,291</b>           | <b>1,019,316</b>   | <b>201,678</b>  | <b>(645,056)</b>                   | <b>4,432,961</b> |
| Segment income before<br>income tax | <b>\$ 725,900</b>        | <b>11,052</b>            | <b>49,571</b>      | <b>(18,900)</b> | <b>(27,661)</b>                    | <b>739,962</b>   |
|                                     | 2019                     |                          |                    |                 |                                    |                  |
|                                     | Domestic sale<br>segment | European<br>sale segment | Poindus<br>Systems | Others          | Adjustments<br>and<br>eliminations | Total            |
| Revenues from external customers\$  | 3,370,389                | 943,734                  | 777,653            | 238,696         | -                                  | 5,330,472        |
| Intra-group revenue                 | 556,344                  | 13,870                   | 22,461             | 13,063          | (605,738)                          | -                |
| Total segment revenue               | <b>\$ 3,926,733</b>      | <b>957,604</b>           | <b>800,114</b>     | <b>251,759</b>  | <b>(605,738)</b>                   | <b>5,330,472</b> |
| Segment income before<br>income tax | <b>\$ 883,096</b>        | <b>44,576</b>            | <b>31,677</b>      | <b>3,019</b>    | <b>(79,864)</b>                    | <b>882,504</b>   |

**FLYTECH TECHNOLOGY CO., LTD. AND SUBSIDIARIES**  
**Notes to the Consolidated Financial Statements**

(b) Product information

Revenues from external customers are detailed below:

| <u>Products</u>        | <u>2020</u>         | <u>2019</u>      |
|------------------------|---------------------|------------------|
| Industrial computers   | \$ 3,591,909        | 4,403,277        |
| Peripherals and others | 841,052             | 927,195          |
|                        | <u>\$ 4,432,961</u> | <u>5,330,472</u> |

(c) Geographic information

In presenting information on the basis of geography, segment revenue is based on the geographical location of customers, and segment assets are based on the geographical location of the assets.

Revenues:

| <u>Region</u>     | <u>2020</u>         | <u>2019</u>      |
|-------------------|---------------------|------------------|
| Europe and Africa | \$ 1,832,485        | 2,497,120        |
| Americas          | 1,698,518           | 2,043,572        |
| Asia              | 783,211             | 643,314          |
| Taiwan            | 118,747             | 146,466          |
|                   | <u>\$ 4,432,961</u> | <u>5,330,472</u> |

Non-current assets:

| <u>Region</u> | <u>December 31,<br/>2020</u> | <u>December 31,<br/>2019</u> |
|---------------|------------------------------|------------------------------|
| Taiwan        | \$ 1,097,969                 | 1,131,363                    |
| Asia          | 25,847                       | 28,923                       |
| Americas      | 3,829                        | 6,130                        |
| Europe        | 340,943                      | 380,419                      |
|               | <u>\$ 1,468,588</u>          | <u>1,546,835</u>             |

Non-current assets include property, plant and equipment, right-of-use assets, intangible assets, and other assets — non-current, but do not include financial instruments and deferred income tax assets.

(d) Major customer information

|  | <u>2020</u>       | <u>2019</u>    |
|--|-------------------|----------------|
| Total consolidated revenue from Customer A | <u>\$ 751,310</u> | <u>776,298</u> |

## **Independent Auditors' Report**

To the Board of Directors  
Flytech Technology Co., Ltd.:

### **Opinion**

We have audited the accompanying parent-company-only financial statements of Flytech Technology Co., Ltd. (the "Company"), which comprise the accompanying parent-company-only balance sheets as of December 31, 2020 and 2019, and the statements of comprehensive income, changes in equity and cash flows for the years then ended, and notes to the parent-company-only financial statements, including a summary of significant accounting policies.

In our opinion, the accompanying parent-company-only financial statements present fairly, in all material respects, the financial position of the Company as of December 31, 2020 and 2019, and its financial performance and its cash flows for the years then ended in accordance with the Regulations Governing the Preparation of Financial Reports by Securities Issuers.

### **Basis for Opinion**

We conducted our audits in accordance with the Regulations Governing Auditing and Certification of Financial Statements by Certified Public Accountants and the auditing standards generally accepted in the Republic of China. Our responsibilities under those standards are further described in the Auditors' Responsibilities for the Audit of the parent-company-only Financial Statements section of our report. We are independent of the Company in accordance with the Certified Public Accountants Code of Professional Ethics in the Republic of China (the "Code"), and we have fulfilled our other ethical responsibilities in accordance with the Code. We believe that the audit evidence we have obtained is sufficient and appropriate to provide a basis of our opinion.

### **Key Audit Matters**

Key audit matters are those matters that, in our professional judgment, were of most significance in our audit of the parent-company-only financial statements of the current period. These matters were addressed in the context of our audit of parent-company-only financial statements as a whole, and in forming our opinion thereon, and we do not provide a separate opinion on these matters.

#### **1. Revenue Recognition**

Please refer to Note 4(n) "Revenue from contracts with customer" for the accounting policy on revenue recognition and Note 6(o) "Revenue from contracts with customers" for the significant account disclosures of revenue.

Description of key audit matter:

The Company redognizes its revenue depending on the various trade terms in each individual sale transaction and service rendered, which are considered to be complex in determining the timing of revenue recognition. Therefore, revenue recognition has been identified as one of the key audit matters.

How the matter was addressed in our audit:

In relation to the key audit matter above, our principal audit procedures included testing the design and operating effectiveness of the Company's internal controls over financial reporting on sales; assessing whether revenue is recognized based on the trade terms with customers through reviewing the related sales contracts or other trade documents; performing a simple test on the sales transactions that took place before and after the balance sheet date, as well as reviewing and understanding the reasonableness for any identified significant sales returns and allowances that took place after the balance sheet date to ensure that revenue was recognized in the appropriate period.

2.Impairment of Goodwill included in investments in subsidiaries accounted for using equity method

Please refer to Note 4(l) “Impairment of non-financial assets” for the significant accounting policy on goodwill impairment, Note 5(b) “Critical accounting judgments and key sources of estimation uncertainty” for estimation uncertainty of impairment of goodwill, and Note 6(f) “Intangible assets” for the related disclosures.

Description of key audit matter:

For impairment test, the recoverable amount of goodwill of relevant cash-generating units involves management’s judgment and estimation with respect to the future cash flows and key assumptions which are complex and involve significant uncertainty. Accordingly, the assessment of impairment of goodwill has been identified as one of the key audit matters.

How the matter was addressed in our audit:

In relation to the key audit matter above, our principal audit procedures included: obtaining the assessment of goodwill impairment provided by the management; assessing the appropriateness of the valuation model and key assumptions, including the discount rate, expected sales growth rate and future cash flow projections, used by the management in measuring the recoverable amount; and assessing the adequacy of the Company’s disclosures with respect to the related information.

**Responsibilities of Management and Those Charged with Governance for the Parent-Company-Only Financial Statements**

Management is responsible for the preparation and fair presentation of the parent-company-only financial statements in accordance with Regulations Governing the Preparation of Financial Reports by Securities Issuers and for such internal control as management determines is necessary to enable the preparation of parent-company-only financial statements that are free from material misstatement, whether due to fraud or error.

In preparing the parent-company-only financial statements, management is responsible for assessing the Company’s ability to continue as a going concern, disclosing, as applicable, matters related to going concern and using the going concern basis of accounting unless management either intends to liquidate the Company or to cease operations, or has no realistic alternative but to do so.

Those charged with governance (including the Audit Committee) are responsible for overseeing the Company's financial reporting process.

### **Auditors' Responsibilities for the Audit of the Parent-Company-Only Financial Statements**

Our objectives are to obtain reasonable assurance about whether the parent-company-only financial statements as a whole are free from material misstatement, whether due to fraud or error, and to issue an auditors' report that includes our opinion. Reasonable assurance is a high level of assurance, but is not a guarantee that an audit conducted in accordance with the auditing standards generally accepted in the Republic of China will always detect a material misstatement when it exists. Misstatements can arise from fraud or error and are considered material if, individually or in the aggregate, they could reasonably be expected to influence the economic decisions of users taken on the basis of these parent-company-only financial statements.

As part of an audit in accordance with auditing standards generally accepted in the Republic of China, we exercise professional judgment and maintained professional skepticism throughout the audit. We also:

1. Identify and assess the risks of material misstatement of the parent-company-only financial statements, whether due to fraud or error, design and perform audit procedures responsive to those risks, and obtain audit evidence that is sufficient and appropriate to provide a basis for our opinion. The risk of not detecting a material misstatement resulting from fraud is higher than for one resulting from error, as fraud may involve collusion, forgery, intentional omissions, misrepresentations, or the override of internal control.
2. Obtain an understanding of internal control relevant to the audit in order to design audit procedures that are appropriate in the circumstances, but not for the purpose of expressing an opinion on the effectiveness of the Company's internal control.
3. Evaluate the appropriateness of accounting policies used and the reasonableness of accounting estimates and related disclosures made by management.
4. Conclude on the appropriateness of management's use of the going concern basis of accounting and, based on the audit evidence obtained, whether a material uncertainty exists related to events or conditions that may cast significant doubt on the Company's ability to continue as a going concern. If we conclude that a material uncertainty exists, we are required to draw attention in our auditors' report to the related disclosures in the parent-company-only financial statements or, if such disclosures are inadequate, to modify our opinion. Our conclusions are based on the audit evidence obtained up to the date of our auditors' report. However, future events or conditions may cause the Company to cease to continue as a going concern.
5. Evaluate the overall presentation, structure and content of the parent-company-only financial statements, including the disclosures, and whether the financial statements represent the underlying transactions and events in a manner that achieves fair presentation.
6. Obtain sufficient appropriate audit evidence regarding the financial information of the investment in other entities accounted for using equity method to express an opinion on these parent-company-only financial statements. We are responsible for the direction, supervision and performance of the audit. We remained solely responsible for our audit opinion.



We communicated with those charged with governance regarding, among other matters, the planned scope and timing of the audit and significant audit findings, including any significant deficiencies in internal control that we identified during our audit.

We also provide those charged with governance with a statement that we have complied with relevant ethical requirements regarding independence, and to communicate with them all relationships and other matters that may reasonably be thought to bear on our independence, and where applicable, related safeguards.

From the matters communicated with those charged with governance, we determined those matters that were of most significance in the audit of the parent-company-only financial statements of the current period and are therefore the key audit matters. We described these matters in our auditors' report unless law or regulation precludes public disclosure about the matter or when, in extremely rare circumstances, we determined that a matter should not be communicated in our report because the adverse consequences of doing so would reasonably be expected to outweigh the public interest benefits of such communication.

The engagement partners on the audit resulting in this independent auditors' report are Wei-Ming Shih and Yung-Sheng Wang.

KPMG  
Taipei, Taiwan (Republic of China)  
March 18, 2021

#### **Notes to Readers**

The accompanying parent-company-only financial statements are intended only to present the financial position, financial performance and cash flows in accordance with the accounting principles and practices generally accepted in the Republic of China and not those of any other jurisdictions. The standards, procedures and practices to audit such parent-company-only financial statements are those generally accepted and applied in the Republic of China.

The independent auditors' report and the accompanying parent-company-only financial statements are the English translation of the Chinese version prepared and used in the Republic of China. If there is any conflict between, or any difference in the interpretation of the English and Chinese language independent auditors' report and parent-company-only financial statements, the Chinese version shall prevail.

(English Translation of Financial Statements Originally Issued in Chinese)  
**FLYTECH TECHNOLOGY CO., LTD.**  
**Balance Sheets**  
**December 31, 2020 and 2019**  
(Expressed in Thousands of New Taiwan Dollars)

|                                 |  | <u>December 31, 2020</u> |            | <u>December 31, 2019</u> |            |
|---------------------------------|--|--------------------------|------------|--------------------------|------------|
|                                 |  | <u>Amount</u>            | <u>%</u>   | <u>Amount</u>            | <u>%</u>   |
| <b>Assets</b>                   |  |                          |            |                          |            |
| <b>Current assets:</b>          |  |                          |            |                          |            |
| 1100                            | Cash and cash equivalents (note 6(a))  | \$ 1,837,648             | 37         | 1,624,116                | 32         |
| 1110                            | Financial assets at fair value through profit or loss – current<br>(note 6(b)) | 12,213                   | -          | 120                      | -          |
| 1136                            | Financial assets at amortised cost – current (note 6(c))                       | -                        | -          | 149,900                  | 3          |
| 1150-1170                       | Notes and accounts receivable (notes 6(d) and (o))                             | 438,262                  | 9          | 546,507                  | 11         |
| 1180                            | Accounts receivable due from related parties (notes 6(d), (o) and 7)           | 142,953                  | 3          | 132,562                  | 3          |
| 130X                            | Inventories (note 6(e))  | 386,560                  | 8          | 372,781                  | 7          |
| 1410-1470                       | Prepayments and other current assets (notes 6(d) and 8)                        | <u>9,746</u>             | <u>-</u>   | <u>17,340</u>            | <u>-</u>   |
| <b>Total current assets</b>     |  | <u>2,827,382</u>         | <u>57</u>  | <u>2,843,326</u>         | <u>56</u>  |
| <b>Non-current assets:</b>      |  |                          |            |                          |            |
| 1550                            | Investments accounted for using equity method (note 6(f))                      | 1,086,722                | 22         | 1,111,662                | 22         |
| 1600                            | Property, plant and equipment (note 6(g))                                      | 1,048,708                | 21         | 1,082,594                | 21         |
| 1755                            | Right-of-use assets (note 6(h))  | 1,560                    | -          | 2,600                    | -          |
| 1780                            | Intangible assets  | 1,273                    | -          | 3,434                    | -          |
| 1840                            | Deferred income tax assets (note 6 (l))  | 26,167                   | -          | 33,526                   | 1          |
| 1915                            | Prepayments for equipment  | 163                      | -          | 267                      | -          |
| 1980                            | Other financial assets – non-current   | <u>285</u>               | <u>-</u>   | <u>285</u>               | <u>-</u>   |
| <b>Total non-current assets</b> |  | <u>2,164,878</u>         | <u>43</u>  | <u>2,234,368</u>         | <u>44</u>  |
| <b>Total assets</b>             |  | <u>\$ 4,992,260</u>      | <u>100</u> | <u>5,077,694</u>         | <u>100</u> |

See accompanying notes to parent-company-only financial statements.

(English Translation of Financial Statements Originally Issued in Chinese)  
**FLYTECH TECHNOLOGY CO., LTD.**  
**Balance Sheets (Continued)**  
**December 31, 2020 and 2019**  
(Expressed in Thousands of New Taiwan Dollars)

|  |   | <u>December 31, 2020</u> |            | <u>December 31, 2019</u> |            |
|--|---|--------------------------|------------|--------------------------|------------|
|  |   | <u>Amount</u>            | <u>%</u>   | <u>Amount</u>            | <u>%</u>   |
| <b>Liabilities and Equity</b>            |   |                          |            |                          |            |
| <b>Current liabilities:</b>              |   |                          |            |                          |            |
| 2120                                     | Financial liabilities at fair value through profit or loss – current<br>(note 6(b)) | \$ 444                   | -          | 26                       | -          |
| 2150-2170                                | Notes and accounts payable  | 198,467                  | 4          | 284,737                  | 6          |
| 2180                                     | Accounts payable to related parties (note 7)  | 3,839                    | -          | 4,138                    | -          |
| 2200                                     | Other payables (note 6(p))  | 186,296                  | 4          | 199,789                  | 4          |
| 2230                                     | Current income tax liabilities  | 185,335                  | 4          | 103,563                  | 2          |
| 2250                                     | Provisions – current (notes 6(j))   | 8,700                    | -          | 10,646                   | -          |
| 2280                                     | Lease liabilities – current (note 6(i))   | 1,049                    | -          | 1,032                    | -          |
| 2300                                     | Other current liabilities (note 6(o))   | <u>21,287</u>            | <u>-</u>   | <u>14,904</u>            | <u>-</u>   |
|  | <b>Total current liabilities</b>  | <u>605,417</u>           | <u>12</u>  | <u>618,835</u>           | <u>12</u>  |
| <b>Non-current liabilities:</b>          |   |                          |            |                          |            |
| 2570                                     | Deferred income tax liabilities (note 6(l))   | 33,064                   | 1          | 30,822                   | 1          |
| 2640                                     | Net defined benefit liabilities (note 6(k))   | 19,077                   | -          | 23,100                   | -          |
| 2580                                     | Lease liabilities – non-current (note 6(i))   | <u>532</u>               | <u>-</u>   | <u>1,581</u>             | <u>-</u>   |
|  | <b>Total non-current liabilities</b>  | <u>52,673</u>            | <u>1</u>   | <u>55,503</u>            | <u>1</u>   |
|  | <b>Total liabilities</b>  | <u>658,090</u>           | <u>13</u>  | <u>674,338</u>           | <u>13</u>  |
| <b>Equity (notes 6(k), (l) and (m)):</b> |   |                          |            |                          |            |
| 3110                                     | Common stock  | 1,430,623                | 29         | 1,430,623                | 28         |
| 3200                                     | Capital surplus   | 597,122                  | 12         | 674,247                  | 13         |
|  | Retained earnings:  |                          |            |                          |            |
| 3310                                     | Legal reserve   | 1,069,391                | 21         | 995,739                  | 20         |
| 3320                                     | Special reserve   | 49,402                   | 1          | 40,344                   | 1          |
| 3350                                     | Unappropriated earnings   | 1,245,571                | 25         | 1,311,805                | 26         |
| 3400                                     | Other equity  | <u>(57,939)</u>          | <u>(1)</u> | <u>(49,402)</u>          | <u>(1)</u> |
|  | <b>Total equity</b>   | <u>4,334,170</u>         | <u>87</u>  | <u>4,403,356</u>         | <u>87</u>  |
|  | <b>Total liabilities and equity</b>   | <u>\$ 4,992,260</u>      | <u>100</u> | <u>5,077,694</u>         | <u>100</u> |

See accompanying notes to parent-company-only financial statements.

(English Translation of Financial Statements Originally Issued in Chinese)  
**FLYTECH TECHNOLOGY CO., LTD.**  
**Statements of Comprehensive Income**  
**For the years ended December 31, 2020 and 2019**  
**(Expressed in Thousands of New Taiwan Dollars , Except for Earnings Per Share)**

|      |  | <u>2020</u>        |             | <u>2019</u>        |             |
|------|--|--------------------|-------------|--------------------|-------------|
|      |  | <u>Amount</u>      | <u>%</u>    | <u>Amount</u>      | <u>%</u>    |
| 4000 | <b>Revenue (notes 6(o) and 7)</b>  | \$ 3,278,733       | 100         | 3,926,733          | 100         |
| 5000 | <b>Cost of revenue (notes 6(e), (g), (i), (j), (k) and (p), 7 and 12)</b>                        | <u>(2,147,158)</u> | <u>(65)</u> | <u>(2,560,450)</u> | <u>(65)</u> |
|      | <b>Gross profit before unrealized gross profit</b>   | 1,131,575          | 35          | 1,366,283          | 35          |
| 5910 | Unrealized (realized) gross profit from sales  | <u>(5,345)</u>     | <u>-</u>    | <u>1,627</u>       | <u>-</u>    |
|      | <b>Gross profit</b>  | <u>1,136,920</u>   | <u>35</u>   | <u>1,364,656</u>   | <u>35</u>   |
|      | <b>Operating expenses (notes 6(g), (h), (i), (k) and (p), 7 and 12):</b>                         |                    |             |                    |             |
| 6100 | Selling expenses   | (136,049)          | (4)         | (156,285)          | (4)         |
| 6200 | Administrative expenses  | (116,267)          | (4)         | (122,034)          | (3)         |
| 6300 | Research and development expenses  | <u>(158,736)</u>   | <u>(5)</u>  | <u>(169,628)</u>   | <u>(4)</u>  |
|      | <b>Total operating expenses</b>  | <u>(411,052)</u>   | <u>(13)</u> | <u>(447,947)</u>   | <u>(11)</u> |
|      | <b>Operating income</b>  | <u>725,868</u>     | <u>22</u>   | <u>916,709</u>     | <u>24</u>   |
|      | <b>Non-operating income and loss (note 6(i) and (q)):</b>  |                    |             |                    |             |
| 7100 | Interest income  | 6,483              | -           | 11,381             | -           |
| 7010 | Other income   | 17,879             | -           | 1,450              | -           |
| 7020 | Other gains and losses   | (9,254)            | -           | (41,050)           | (1)         |
| 7050 | Finance costs  | (35)               | -           | (30)               | -           |
| 7375 | Share of loss of associates accounted for using equity method                                    | <u>(15,042)</u>    | <u>-</u>    | <u>(5,364)</u>     | <u>-</u>    |
|      |  | <u>31</u>          | <u>-</u>    | <u>(33,613)</u>    | <u>(1)</u>  |
|      | <b>Income before income tax</b>  | 725,899            | 22          | 883,096            | 23          |
| 7950 | Less: Income tax expenses (note 6(l))  | <u>(136,255)</u>   | <u>(4)</u>  | <u>(146,574)</u>   | <u>(4)</u>  |
|      | <b>Net income</b>  | <u>589,644</u>     | <u>18</u>   | <u>736,522</u>     | <u>19</u>   |
|      | <b>Other comprehensive income:</b>   |                    |             |                    |             |
| 8310 | <b>Items that will not be reclassified subsequently to profit or loss</b>                        |                    |             |                    |             |
| 8311 | Remeasurements of defined benefit plans  | 241                | -           | 741                | -           |
| 8330 | Share of remeasurements of defined benefit plans of associates accounted for using equity method | (977)              | -           | (2,194)            | -           |
| 8349 | Income tax related to items that may be reclassified subsequently to profit or loss              | <u>(48)</u>        | <u>-</u>    | <u>(148)</u>       | <u>-</u>    |
|      |  | <u>(784)</u>       | <u>-</u>    | <u>(1,601)</u>     | <u>-</u>    |
| 8360 | <b>Items that may be reclassified subsequently to profit or loss</b>                             |                    |             |                    |             |
| 8361 | Exchange differences on translation of foreign operations  | (7,753)            | -           | (7,457)            | -           |
| 8399 | Income tax related to items that may be reclassified subsequently to profit or loss              | <u>-</u>           | <u>-</u>    | <u>-</u>           | <u>-</u>    |
|      |  | <u>(7,753)</u>     | <u>-</u>    | <u>(7,457)</u>     | <u>-</u>    |
|      | <b>Other comprehensive income (loss) for the year</b>  | <u>(8,537)</u>     | <u>-</u>    | <u>(9,058)</u>     | <u>-</u>    |
|      | <b>Total comprehensive income for the year</b>   | <u>\$ 581,107</u>  | <u>18</u>   | <u>727,464</u>     | <u>19</u>   |
|      | <b>Earnings per share (in New Taiwan dollars) (note 6(n)) :</b>                                  |                    |             |                    |             |
| 9750 | Basic earnings per share   | <u>\$ 4.12</u>     |             | <u>5.15</u>        |             |
| 9850 | Diluted earnings per share   | <u>\$ 4.09</u>     |             | <u>5.10</u>        |             |

See accompanying notes to parent-company-only financial statements.

(English Translation of Financial Statements Originally Issued in Chinese)

**FLYTECH TECHNOLOGY CO., LTD.**

**Statements of Changes in Equity**

**For the years ended December 31, 2020 and 2019**

**(Expressed in Thousands of New Taiwan Dollars)**

|   | Retained earnings   |                 |                  |                 |                         | Total other equity interest |  |   |                 | Total equity     |
|---|---------------------|-----------------|------------------|-----------------|-------------------------|-----------------------------|--|---|-----------------|------------------|
|   | Common stock        | Capital surplus | Legal reserve    | Special reserve | Unappropriated earnings | Total                       | Foreign currency translation differences | Remeasurements of defined benefit plans | Total           |                  |
| <b>Balance at January 1, 2019</b>   | \$ 1,430,623        | 745,778         | 915,594          | 37,221          | 1,302,331               | 2,255,146                   | (35,732)                                 | (4,612)                                 | (40,344)        | 4,391,203        |
| Appropriation of earnings:  |                     |                 |                  |                 |                         |                             |  |   |                 |                  |
| Legal reserve   | -                   | -               | 80,145           | -               | (80,145)                | -                           | -  | -                                       | -               | -                |
| Special reserve   | -                   | -               | -                | 3,123           | (3,123)                 | -                           | -  | -                                       | -               | -                |
| Cash dividends  | -                   | -               | -                | -               | (643,780)               | (643,780)                   | -  | -                                       | -               | (643,780)        |
| Cash dividends from capital surplus   | -                   | (71,531)        | -                | -               | -                       | -                           | -  | -                                       | -               | (71,531)         |
| Net income in 2019  | -                   | -               | -                | -               | 736,522                 | 736,522                     | -  | -                                       | -               | 736,522          |
| Other comprehensive income (loss) in 2019   | -                   | -               | -                | -               | -                       | -                           | (7,457)                                  | (1,601)                                 | (9,058)         | (9,058)          |
| Total comprehensive income (loss) in 2019   | -                   | -               | -                | -               | 736,522                 | 736,522                     | (7,457)                                  | (1,601)                                 | (9,058)         | 727,464          |
| <b>Balance at December 31, 2019</b>   | 1,430,623           | 674,247         | 995,739          | 40,344          | 1,311,805               | 2,347,888                   | (43,189)                                 | (6,213)                                 | (49,402)        | 4,403,356        |
| Appropriation of earnings:  |                     |                 |                  |                 |                         |                             |  |   |                 |                  |
| Legal reserve   | -                   | -               | 73,652           | -               | (73,652)                | -                           | -  | -                                       | -               | -                |
| Special reserve   | -                   | -               | -                | 9,058           | (9,058)                 | -                           | -  | -                                       | -               | -                |
| Cash dividends  | -                   | -               | -                | -               | (572,249)               | (572,249)                   | -  | -                                       | -               | (572,249)        |
| Cash dividends from capital surplus   | -                   | (71,531)        | -                | -               | -                       | -                           | -  | -                                       | -               | (71,531)         |
| Difference between consideration and carrying amount arising from acquisition of shares in subsidiaries | -                   | (6,683)         | -                | -               | (919)                   | (919)                       | -  | -                                       | -               | (7,602)          |
| Reorganization under common control   | -                   | 1,089           | -                | -               | -                       | -                           | -  | -                                       | -               | 1,089            |
| Net income in 2020  | -                   | -               | -                | -               | 589,644                 | 589,644                     | -  | -                                       | -               | 589,644          |
| Other comprehensive income (loss) in 2020   | -                   | -               | -                | -               | -                       | -                           | (7,753)                                  | (784)                                   | (8,537)         | (8,537)          |
| Total comprehensive income (loss) in 2020   | -                   | -               | -                | -               | 589,644                 | 589,644                     | (7,753)                                  | (784)                                   | (8,537)         | 581,107          |
| <b>Balance at December 31, 2020</b>   | <b>\$ 1,430,623</b> | <b>597,122</b>  | <b>1,069,391</b> | <b>49,402</b>   | <b>1,245,571</b>        | <b>2,364,364</b>            | <b>(50,942)</b>                          | <b>(6,997)</b>                          | <b>(57,939)</b> | <b>4,334,170</b> |

See accompanying notes to parent-company-only financial statements.

(English Translation of Financial Statements Originally Issued in Chinese)

**FLYTECH TECHNOLOGY CO., LTD.**

**Statements of Cash Flows**

**For the years ended December 31, 2020 and 2019**

**(Expressed in Thousands of New Taiwan Dollars)**

|  | <u>2020</u>      | <u>2019</u>      |
|--|------------------|------------------|
| <b>Cash flows from operating activities:</b>   |                  |                  |
| Income before income tax   | \$ 725,899       | 883,096          |
| <b>Adjustments for:</b>  |                  |                  |
| <b>Adjustments to reconcile profit (loss):</b>   |                  |                  |
| Depreciation   | 79,044           | 81,268           |
| Amortization   | 2,414            | 3,189            |
| Valuation (gain) loss on financial assets and liabilities at fair value<br>through profit or loss, net | (1,675)          | 650              |
| Share of loss of subsidiaries accounted for using equity method  | 15,042           | 5,364            |
| Loss on disposal of property, plant and equipment  | 287              | -                |
| Interest expense   | 35               | 30               |
| Interest income  | (6,483)          | (11,381)         |
| Unrealized (realized) gross profit on sales to subsidiaries  | (5,345)          | 1,627            |
| <b>Total non-cash profit and loss</b>  | <u>83,319</u>    | <u>80,747</u>    |
| <b>Changes in operating assets and liabilities:</b>  |                  |                  |
| <b>Changes in operating assets:</b>  |                  |                  |
| Notes and accounts receivable  | 108,245          | 36,994           |
| Accounts receivable from related parties   | (10,391)         | 36,652           |
| Inventories  | (13,779)         | 97,210           |
| Prepayments and other current assets   | 5,449            | 6,411            |
| <b>Net changes in operating assets</b>   | <u>89,524</u>    | <u>177,267</u>   |
| <b>Changes in operating liabilities:</b>   |                  |                  |
| Notes and accounts payable   | (86,270)         | (126,284)        |
| Accounts payable to related parties  | (299)            | (4,047)          |
| Other payables   | (16,948)         | 4,691            |
| Provisions – current   | (1,946)          | (2,089)          |
| Other current liabilities  | 6,383            | (7,943)          |
| Net defined benefit liabilities  | (3,782)          | (2,146)          |
| <b>Net changes in operating liabilities</b>  | <u>(102,862)</u> | <u>(137,818)</u> |
| <b>Total changes in operating assets and liabilities</b>   | <u>(13,338)</u>  | <u>39,449</u>    |
| Cash provided by operations  | 795,880          | 1,003,292        |
| Income taxes paid  | (44,930)         | (146,464)        |
| <b>Net cash provided by operating activities</b>   | <u>750,950</u>   | <u>856,828</u>   |

(Continued)

See accompanying notes to parent-company-only financial statements.

(English Translation of Financial Statements Originally Issued in Chinese)

**FLYTECH TECHNOLOGY CO., LTD.**

**Statements of Cash Flows (Continued)**

**For the years ended December 31, 2020 and 2019**

**(Expressed in Thousands of New Taiwan Dollars)**

|  | <u>2020</u>                | <u>2019</u>             |
|--|----------------------------|-------------------------|
| <b>Cash flows from investing activities:</b>                                     |                            |                         |
| Acquisition of financial assets at amortised cost                                | -                          | (149,900)               |
| Proceeds from disposal of financial assets at amortised cost                     | 149,900                    | -                       |
| Acquisition of financial assets at fair value through profit or loss             | (10,000)                   | -                       |
| Acquisition of investments accounted for using equity method                     | -                          | (6,258)                 |
| Additions to property, plant and equipment (including prepayments for equipment) | (41,115)                   | (54,757)                |
| Proceeds from disposal of property, plant and equipment                          | 269                        | -                       |
| Additions of intangible assets   | (253)                      | (2,786)                 |
| Decrease in other financial assets   | -                          | 2,001                   |
| Interest received  | 8,628                      | 9,234                   |
| <b>Net cash flows provided by (used in) investing activities</b>                 | <u>107,429</u>             | <u>(202,466)</u>        |
| <b>Cash flows from financing activities:</b>                                     |                            |                         |
| Payment of lease liabilities   | (1,032)                    | (970)                   |
| Cash dividends   | (643,780)                  | (715,311)               |
| Interest paid  | (35)                       | (30)                    |
| <b>Net cash flows used in financing activities</b>                               | <u>(644,847)</u>           | <u>(716,311)</u>        |
| <b>Net increase (decrease) in cash and cash equivalents</b>                      | 213,532                    | (61,949)                |
| <b>Cash and cash equivalents at beginning of year</b>                            | <u>1,624,116</u>           | <u>1,686,065</u>        |
| <b>Cash and cash equivalents at end of year</b>                                  | <u><b>\$ 1,837,648</b></u> | <u><b>1,624,116</b></u> |

See accompanying notes to parent-company-only financial statements.

(English Translation of Financial Statements Originally Issued in Chinese)  
**FLYTECH TECHNOLOGY CO., LTD.**  
**Notes to the Financial Statements**  
**For the years ended December 31, 2020 and 2019**  
(Expressed in Thousands of New Taiwan Dollars, Unless Otherwise Specified)

**1. Organization and business**

Flytech Technology Co., Ltd. (the “Company”) was incorporated on August 13, 1984, as a company limited by shares under the Company Act of the Republic of China (“R.O.C.”) and registered under the Ministry of Economic Affairs, R.O.C. The address of the Company’s registered office is No. 168, Sing-Ai Road, Neihu, Taipei, Taiwan. The Company is engaged in the design, manufacture and sale of computers and peripherals.

**2. Authorization of the parent company only financial statements**

These parent-company-only financial statements were authorized for issue by the Board of Directors on March 18, 2021.

**3. Application of new and revised accounting standards and interpretations:**

- (a) The impact of the International Financial Reporting Standards (“IFRSs”) endorsed by the Financial Supervisory Commission, R.O.C. (“FSC”) which have already been adopted.

The Company has initially adopted the following new amendments, which do not have a significant impact on its financial statements, from January 1, 2020:

- Amendments to IFRS 3 “Definition of a Business”
- Amendments to IFRS 9, IAS 39 and IFRS 7 “Interest Rate Benchmark Reform”
- Amendments to IAS 1 and IAS 8 “Definition of Material”
- Amendments to IFRS 16 “COVID-19-Related Rent Concessions”

- (b) The impact of IFRS endorsed by the FSC but not yet effective

The Company assesses that the adoption of the following new amendments, effective for annual period beginning on January 1, 2021, would not have a significant impact on its financial statements:

- Amendments to IFRS 4 “Extension of the Temporary Exemption from Applying IFRS 9”
- Amendments to IFRS 9, IAS 39, IFRS 7, IFRS 4 and IFRS 16 “Interest Rate Benchmark Reform – Phase 2”

- (c) The impact of IFRS issued by IASB but not yet endorsed by the FSC

The Company does not expect the following new and amended standards, which have yet to be endorsed by the FSC, to have a significant impact on its financial statements:

- Amendments to IFRS 10 and IAS 28 “Sale or Contribution of Assets Between an Investor and Its Associate or Joint Venture”



## FLYTECH TECHNOLOGY CO., LTD.

### Notes to the Financial Statements

- IFRS 17 “Insurance Contracts” and amendments to IFRS 17 “Insurance Contracts”
- Amendments to IAS 1 “Classification of Liabilities as Current or Non-current”
- Amendments to IAS 16 “Property, Plant and Equipment – Proceeds before Intended Use”
- Amendments to IAS 37 “Onerous Contracts – Cost of Fulfilling a Contract”
- Annual Improvements to IFRS Standards 2018-2020
- Amendments to IFRS 3 “Reference to the Conceptual Framework”
- Amendments to IAS 1 “Disclosure of Accounting Policies”
- Amendments to IAS 8 “Definition of Accounting Estimates”

#### 4. Summary of significant accounting policies

The significant accounting policies presented in the parent-company-only financial statements are summarized as follows and have been applied consistently to all periods presented in these financial statements.

(a) Statement of compliance

The accompanying parent-company-only financial statements have been prepared in accordance with the “Regulations Governing the Preparation of Financial Reports by Securities Issuers”.

(b) Basis of preparation

(i) Basis of measurement

The accompanying parent-company-only financial statements have been prepared on a historical cost basis except for the following items in the balance sheets:

- 1) Financial instruments at fair value through profit or loss (including derivative financial instruments and contingent consideration);
- 2) The defined benefit liabilities are measured at present value of the benefit obligation less the fair value of plan assets.

(ii) Functional and presentation currency

The functional currency is determined based on the primary economic environment in which the entity operates. The parent-company-only financial statements are presented in New Taiwan dollars, which is the Company’s functional currency. Except when otherwise indicated, all financial information presented in New Taiwan dollars has been rounded to the nearest thousand.

## FLYTECH TECHNOLOGY CO., LTD.

### Notes to the Financial Statements

(c) Foreign currency

(i) Foreign currency transactions

Foreign currency transactions are translated into the functional currency using the exchange rates prevailing at the dates of the transactions. At the end of each subsequent reporting period, monetary items denominated in foreign currencies are translated into the functional currencies using the exchange rate at that date. Non-monetary items denominated in foreign currencies that are measured at fair value are translated into the functional currencies using the exchange rate at the date that the fair value was determined. Non-monetary items denominated in foreign currencies that are measured based on historical cost are translated using the exchange rate at the date of the transaction.

Exchange differences are generally recognized in profit or loss, except for an investment in equity securities designated as at fair value through other comprehensive income are recognized in other comprehensive income.

(ii) Foreign operations

The assets and liabilities of foreign operations, including goodwill and fair value adjustments arising on acquisition, are translated into the presentation currency at the exchange rates at the reporting date. The income and expenses of foreign operations are translated into the presentation currency at the average exchange rate. Exchange differences are recognized in other comprehensive income.

On the disposal of a foreign operation which involves a loss of control over a subsidiary or loss of significant influence over an associate that includes a foreign operation, all of the exchange differences accumulated in equity in respect of that operation attributable to the shareholders of the Company are entirely reclassified to profit or loss. In the case of a partial disposal that does not result in the Company losing control over a subsidiary, the proportionate share of accumulated exchange differences is reclassified to non-controlling interests. For a partial disposal of the Company's ownership interest in an associate or joint venture, the proportionate share of the accumulated exchange differences in equity is reclassified to profit or loss.

(d) Classification of current and non-current assets and liabilities

An asset is classified as current when one of following criteria is met; all other assets are classified as non-current assets.

- (i) It is expected to be realized, or intended to be sold or consumed in the normal operating cycle;
- (ii) It is held primarily for the purpose of trading;
- (iii) It is expected to be realized within twelve months after the reporting date; or
- (iv) The asset is cash or a cash equivalent unless the asset is restricted from being exchanged or used to settle a liability for at least twelve months after the reporting period.

A liability is classified as current when one of following criteria is met; all other liabilities are classified as non-current liabilities:

- (i) It is expected to be settled in the normal operating cycle;
- (ii) It is held primarily for the purpose of trading;
- (iii) It is due to be settled within twelve months after the reporting period; or

## FLYTECH TECHNOLOGY CO., LTD.

### Notes to the Financial Statements

(iv) The Company does not have an unconditional right to defer settlement of the liability for at least twelve months after the reporting period.

(e) Cash and cash equivalents

Cash comprises cash on hand, demand deposits and checking deposits. Cash equivalents are short-term and highly liquid investments that are readily convertible to known amounts of cash and are subject to an insignificant risk of changes in value. Time deposits that meet the aforesaid criteria and are not held for investing purposes are also classified as cash equivalents.

(f) Financial instruments

Trade receivables are initially recognized when they are originated. All other financial assets and financial liabilities are initially recognized when the Company becomes a party to the contractual provisions of the instrument. A financial asset (unless it is a trade receivable without a significant financing component) or financial liability is initially measured at fair value plus, for an item not at fair value through profit or loss (FVTPL), transaction costs that are directly attributable to its acquisition or issue. A trade receivable without a significant financing component is initially measured at the transaction price.

(i) Financial assets

On initial recognition, financial assets are classified into the following categories: measured at amortized cost and fair value through profit or loss (FVTPL). Regular way purchases or sales of financial assets are recognized or derecognized on a trade-date basis.

The Company shall reclassify all affected financial assets on the first day of the first reporting period only when it changes its business model for managing its financial assets.

1) Financial assets measured at amortized cost

A financial asset is measured at amortized cost if it meets both of the following conditions and is not designated as at FVTPL:

- it is held within a business model whose objective is to hold assets to collect contractual cash flows; and
- its contractual terms give rise on specified dates to cash flows that are solely payments of principal and interest on the principal amount outstanding.

These assets are subsequently measured at amortized cost, which is the amount at which the financial asset is measured at initial recognition, plus/minus, the cumulative amortization using the effective interest method, adjusted for any loss allowance. Interest income, foreign exchange gains and losses, and impairment loss, are recognized in profit or loss. Any gain or loss on derecognition is recognized in profit or loss.

## FLYTECH TECHNOLOGY CO., LTD.

### Notes to the Financial Statements

#### 2) Fair value through profit or loss (FVTPL)

All financial assets not classified as amortized cost described as above are measured at FVTPL, including derivative financial assets. On initial recognition, the Company may irrevocably designate a financial asset, which meets the requirements to be measured at amortized cost, as at FVTPL if doing so eliminates or significantly reduces an accounting mismatch that would otherwise arise.

These assets are subsequently measured at fair value. Net gains and losses, including any interest or dividend income, are recognized in profit or loss.

#### 3) Impairment of financial assets

The Company recognizes loss allowances for expected credit losses (ECL) on financial assets measured at amortized cost (including cash and cash equivalents, financial assets at amortized cost, notes and accounts receivable, accounts receivable from related parties and other financial assets).

The Company measures loss allowances at an amount equal to lifetime ECL, except for the following financial assets which are measured as 12-month ECL:

- bank balances for which credit risk (i.e. the risk of default occurring over the expected life of the financial instrument) has not increased significantly since initial recognition.

Loss allowance for accounts receivables are always measured at an amount equal to lifetime ECL.

Lifetime ECL are the ECL that result from all possible default events over the expected life of a financial instrument. 12-month ECL are the portion of ECL that result from default events that are possible within the 12 month after the reporting date (or a shorter period if the expected life of the instrument is less than 12 months).

The maximum period considered when estimating ECL is the maximum contractual period over which the Company is exposed to credit risk.

When determining whether the credit risk of a financial asset has increased significantly since initial recognition and when estimating ECL, the Company considers reasonable and supportable information that is relevant and available without undue cost or effort. This includes both quantitative and qualitative information and analysis based on the Company's historical experience and informed credit assessment as well as forward-looking information.

ECL are a probability-weighted estimate of credit losses. Credit losses are measured as the present value of all cash shortfalls (i.e., the difference between the cash flows due to the Company in accordance with the contract and the cash flows that the Company expects to receive). ECL are discounted at the effective interest rate of the financial asset.

Loss allowances for financial assets measured at amortized cost are deducted from the gross carrying amount of the assets.

The gross carrying amount of a financial asset is written off, either partially or in full, to

## **FLYTECH TECHNOLOGY CO., LTD.**

### **Notes to the Financial Statements**

the extent that there is no realistic prospect of recovery. The Company individually makes an assessment with respect to the timing and amount of write-off based on whether there is a reasonable expectation of recovery. The Company expects no significant recovery from the amount written off. However, financial assets that are written off could still be subject to enforcement activities in order to comply with the Company's procedures for recovery of amounts due.

#### 4) Derecognition of financial assets

The Company derecognized a financial asset when the contractual rights to the cash flows from the financial asset expire, or it transfers the rights to receive the contractual cash flows in a transaction in which substantially all of the risks and rewards of ownership of the financial asset are transferred or in which the Company neither transfers nor retains substantially all of the risks and rewards of ownership and it does not retain control of the financial asset.

The Company enters into transactions whereby it transfers assets recognized in its statement of balance sheet, but retains either all or substantially all of the risks and rewards of the transferred assets. In these cases, the transferred assets are not derecognized.

#### (ii) Financial liabilities

##### 1) Financial liabilities

Financial liabilities are classified as measured at amortized cost or FVTPL. A financial liability is classified as at FVTPL if it is classified as held-for-trading, it is a derivative or it is designated as such on initial recognition. Financial liabilities at FVTPL are measured at fair value and net gains and losses, including any interest expense, are recognized in profit or loss.

Other financial liabilities are subsequently measured at amortized cost using the effective interest method. Interest expense and foreign exchange gains and losses are recognized in profit or loss. Any gain or loss on derecognition is also recognized in profit or loss.

##### 2) Derecognition of financial liabilities

The Company derecognizes a financial liability when its contractual obligation has been fulfilled or cancelled, or has expired. The Company also derecognizes a financial liability when its terms are modified and the cash flows of the modified liability are substantially different, in which case a new financial liability based on the modified terms is recognized at fair value.

On derecognition of a financial liability, the difference between the carrying amount of a financial liability extinguished and the consideration paid (including any non-cash assets transferred or liabilities assumed) is recognized in profit or loss.

## FLYTECH TECHNOLOGY CO., LTD.

### Notes to the Financial Statements

#### 3) Offsetting of financial assets and liabilities

Financial assets and financial liabilities are offset and the net amount presented in the statement of balance sheet when, and only when, the Company has the legally enforceable right to set off the amounts and it intends either to settle them on a net basis or to realize the asset and settle the liability simultaneously.

#### (iii) Derivative financial instruments

The Company holds derivative financial instruments to hedge its foreign currency exposures. Derivatives are initially measured at fair value, and attributable transaction costs are recognized in profit or loss as incurred. Subsequent to initial recognition, derivatives are measured at fair value, and changes therein are recognized in profit or loss. If the valuation of a derivative instrument results in a positive fair value, it is classified as a financial asset; otherwise, it is classified as a financial liability.

#### (g) Inventories

Inventories are measured at the lower of cost and net realizable value. The cost of inventories is calculated based on the weighted-average method and includes expenditure incurred in acquiring the inventories, production or conversion costs, and other cost incurred in bringing them to a location and condition ready for sale. Fixed manufacturing overhead is allocated to finished products and work in process based on the higher of normal capacity or actual capacity; variable manufacturing overhead is allocated based on the actual capacity of machinery and equipment. Net realizable value represents the estimated selling price in the ordinary course of business, less all estimated costs of completion and necessary selling expenses.

#### (h) Investments in subsidiaries

When preparing the parent-company-only financial statements, investments in subsidiaries, which are controlled by the Company, are accounted for using the equity method. Under equity method, the net income, other comprehensive income and equity in the parent-company-only financial statement are the same as those attributable to the shareholders of the Company in the consolidated financial statements. Changes in the Company's ownership interest in a subsidiary that do not result in the loss of control are accounted for as equity transactions.

The Company uses acquisition method for the acquisitions of its new subsidiaries. Goodwill is measured at the excess of the acquisition-date fair value of consideration transferred (including any non-controlling interest in the acquired) over the net of the acquisition-date amounts of the identifiable assets acquired and liabilities assumed (generally at fair value). If the residual balance is negative, the Company shall re-assess whether it has correctly identified all of the assets acquired and liabilities assumed, and recognize any additional assets or liabilities that are identified in that review, and shall recognize a gain on the bargain purchase thereafter.

## FLYTECH TECHNOLOGY CO., LTD.

### Notes to the Financial Statements

Contingent consideration as part of the consideration transferred is measured at the acquisition date fair value. Any fluctuation of the fair value during the measurement period after the acquisition date is retrospectively adjusted to the acquisition cost and goodwill. The adjustments are to reflect new information obtained about facts and circumstances that existed as of the acquisition date. The measurement period shall not exceed one year from the acquisition date. For the fair value adjustments of the contingent consideration that occurred not during the measurement period, the accounting treatment will be based on the classification of contingent consideration. Contingent consideration classified as equity can not be re-measured and has to be adjusted under owner's equity.

Other contingent consideration will be measured at fair value at each reporting date and changes in fair value will be recognized in profit or loss or other comprehensive income.

Acquisition-related costs are expensed as incurred except for the costs related to issuance of debt or equity instruments.

#### (i) Property, plant and equipment

##### (i) Recognition and measurement

Items of property, plant and equipment are measured at cost, which includes capitalized borrowing costs, less accumulated depreciation and accumulated impairment losses.

If significant parts of an item of property, plant and equipment have different useful lives, they are accounted for as separate items (major components) of property, plant and equipment.

Any gain or loss on disposal of an item of property, plant and equipment is recognized in profit or loss.

##### (ii) Subsequent costs

Subsequent expenditure is capitalized only if it is probable that the future economic benefits associated with the expenditure will flow to the Company.

##### (iii) Depreciation

Depreciation is calculated on the cost of an asset less its residual value and is recognized in profit or loss on a straight-line basis over the estimated useful lives of each component of an item of property, plant and equipment. Land is not depreciated.

The estimated useful lives for property, plant and equipment are as follows: machinery and equipment - 3 to 12 years; mold equipment - 4 to 10 years; office equipment - 3 to 15 years; other equipment - 2 to 10 years; buildings are depreciated over the following useful lives of significant individual components: main structure - 50 years; mechanical & electrical power equipment - 20 years; and air-conditioning system - 10 years.

Depreciation methods, useful lives, and residual values are reviewed at each reporting date, with the effect of any changes in estimate accounted for on a prospective basis.

## FLYTECH TECHNOLOGY CO., LTD.

### Notes to the Financial Statements

#### (j) Leases

##### (i) Identifying a lease

At inception of a contract, the Company assesses whether a contract is, or contains, a lease. A contract is, or contains, a lease if the contract conveys the right to control the use of an identified asset for a period of time in exchange for consideration. To assess whether a contract conveys the right to control the use of an identified asset, the Company assesses whether:

- 1) the contract involves the use of an identified asset – this may be specified explicitly or implicitly, and should be physically distinct or represent substantially all of the capacity of a physically distinct asset. If the supplier has a substantive substitution right, then the asset is not identified; and
- 2) the customer has the right to obtain substantially all of the economic benefits from use of the asset throughout the period of use; and
- 3) the customer has the right to direct the use of the asset if either:
  - the customer has the right to direct how and for what purpose the asset is used throughout the period of use; or
  - the relevant decisions about how and for what purpose the asset is used are predetermined and:
    - the customer has the right to operate the asset throughout the period of use, without the supplier having the right to change those operating instructions; or
    - the customer designed the asset in a way that predetermines how and for what purpose it will be used throughout the period of use.

At inception or on reassessment of a contract that contains a lease component, the Company allocates the consideration in the contract to each lease component on the basis of their relative stand-alone prices. However, for the leases of land and buildings in which it is a lessee, the Company has elected not to separate non-lease components and account for each lease component and any associated non-lease components as a single lease component.

##### (ii) As a lessee

The Company recognizes a right-of-use asset and a lease liability at the lease commencement date. The right-of-use asset is initially measured at cost, which comprises the initial amount of the lease liability adjusted for any lease payments made at or before the commencement date, plus any initial direct costs incurred and an estimate of costs to dismantle and remove the underlying asset or to restore the underlying asset or the site on which it is located, less any lease incentives received.

The right-of-use asset is subsequently depreciated using the straight-line method from the commencement date to the earlier of the end of the useful life of the right-of-use asset or the end of the lease term. In addition, the right-of-use asset is periodically reduced by impairment losses, if any, and adjusted for certain remeasurements of the lease liability.



## FLYTECH TECHNOLOGY CO., LTD.

### Notes to the Financial Statements

The lease liability is initially measured at the present value of the lease payments that are not paid at the commencement date, discounted using the interest rate implicit in the lease or, if that rate cannot be reliably determined, the Company's incremental borrowing rate. Generally, the Company uses its incremental borrowing rate as the discount rate.

Lease payments included in the measurement of the lease liability comprise the following:

- fixed payments, including in-substance fixed payments;
- variable lease payments that depend on an index or a rate, initially measured using the index or rate as at the commencement date.

The lease liability is measured at amortized cost using the effective interest method. It is remeasured when:

- there is a change in future lease payments arising from the change in an index or rate; or
- there is a change of its assessment on whether it will exercise a purchase, extension or termination option; or
- there is any lease modifications in lease subject, scope of the lease or other terms

When the lease liability is remeasured, other than lease modifications, a corresponding adjustment is made to the carrying amount of the right-of-use asset, or in profit and loss if the carrying amount of the right-of-use asset has been reduced to zero.

When the lease liability is remeasured to reflect the partial or full termination of the lease for lease modifications that decrease the scope of the lease, the Company accounts for the remeasurement of the lease liability by decreasing the carrying amount of the right-of-use asset to reflect the partial or full termination of the lease, and recognize in profit or loss any gain or loss relating to the partial or full termination of the lease.

The Company presents right-of-use assets that do not meet the definition of investment and lease liabilities as a separate line item respectively in the balance sheets.

The Company has elected not to recognize right-of-use assets and lease liabilities for short-term leases and leases of low-value assets. The Company recognizes the lease payments associated with these leases as an expense on a straight-line basis over the lease term.

#### (k) Intangible assets

The Company's intangible assets are acquired software, which are carried at cost less accumulated amortization and accumulated impairment losses. Amortization is recognized in profit or loss on a straight-line basis over 2 to 5 years.

Amortization methods, useful lives and residual values are reviewed at each reporting date and adjusted if appropriate.

## **FLYTECH TECHNOLOGY CO., LTD.**

### **Notes to the Financial Statements**

#### **(l) Impairment of non-financial assets**

At each reporting date, the Company reviews the carrying amounts of its non-financial assets (other than inventories and deferred tax assets) to determine whether there is any indication of impairment. If any such indication exists, then the asset's recoverable amount is estimated. Goodwill is tested annually for impairment.

For impairment testing, assets are grouped together into the smallest Company of assets that generates cash inflows from continuing use that are largely independent of the cash inflows of other assets or CGUs. Goodwill arising from a business combination is allocated to CGUs or groups of CGUs that are expected to benefit from the synergies of the combination.

The recoverable amount of an asset or CGU is the greater of its value in use and its fair value less costs to sell. Value in use is based on the estimated future cash flows, discounted to their present value using a pre-tax discount rate that reflects current market assessments of the time value of money and the risks specific to the asset or CGU.

An impairment loss is recognized if the carrying amount of an asset or CGU exceeds its recoverable amount. Impairment losses are recognized in profit or loss. They are allocated first to reduce the carrying amount of any goodwill allocated to the CGU, and then to reduce the carrying amounts of the other assets in the CGU on a pro rata basis.

An impairment loss in respect of goodwill is not reversed. For other assets, an impairment loss is reversed only to the extent that the asset's carrying amount does not exceed the carrying amount that would have been determined, net of depreciation or amortization, if no impairment loss had been recognized.

#### **(m) Provisions**

Provisions are recognized when the Company has a present obligation as a result of a past event, it is probable that the Company will be required to settle the obligation, and a reliable estimate can be made of the amount of the obligation.

A provision for warranties is recognized when the underlying products or services are sold, based on historical warranty data and the weighting of all possible outcomes against their associated probabilities.

#### **(n) Revenue from contracts with customers**

Revenue is measured based on the consideration to which the Company expects to be entitled in exchange for transferring goods or services to a customer. The Company recognizes revenue when it satisfies a performance obligation by transferring its control of goods or services to a customer.

## FLYTECH TECHNOLOGY CO., LTD.

### Notes to the Financial Statements

(i) Sale of goods

The Company recognizes revenue when its control of the products has been transferred, being when the products are delivered to the customer, the customer has full discretion over the channel and price to sell the products, and there is no unfulfilled obligation that could affect the customer's acceptance of the products. Delivery occurs when the products have been shipped to the specific location, the risks of obsolescence and loss have been transferred to the customer, and either the customer has accepted the products in accordance with the sales contract or the Company has objective evidence that all criteria for acceptance have been satisfied.

The Company grants its customers the right to return the faulty goods under the standard warranty terms and has recognized warranty provisions for this obligation, please refer to note 6(j).

A receivable is recognized when the goods are delivered as this is the point in time that the Company has a right to an amount of consideration that is unconditional.

(ii) Revenue from service rendered

Revenue from service rendered is recognized by reference to the stage of completion at the reporting date.

(o) Government grants

The Company recognizes an unconditional government grant related to its operation and salary as other income when the grant becomes receivable.

(p) Employee benefits

(i) Defined contribution plans

Obligations for contributions to defined contribution plans are expensed as the related service is provided.

(ii) Defined benefit plans

The Company's net obligation in respect of defined benefit plans is calculated separately for each the plan by estimating the amount of future benefit that employees have earned in the current and prior periods, discounting that amount and deducting the fair value of any plan assets. The discount rate for calculating the present value of the defined benefit obligation refers to the interest rate of high-quality government bonds that are denominated in the currency in which the benefits will be paid, and that have terms to maturity approximating the term of the related pension obligation. The defined benefit obligation is calculated annually by qualified actuaries using the projected unit credit method.

## FLYTECH TECHNOLOGY CO., LTD.

### Notes to the Financial Statements

The remeasurements of the net defined benefit liability (asset) comprise (i) actuarial gains and losses; (ii) return on plan assets, excluding amounts included in net interest on the net defined benefit liability (asset); and (iii) any change in the effect of the asset ceiling, excluding amounts included in net interest on the net defined benefit liability (asset). The remeasurements of the net defined benefit liability (asset) are recognized in other comprehensive income and reflected in other equity.

The Company recognizes gains or losses on the curtailment or settlement of a defined benefit plan when the curtailment or settlement occurs. The gain or loss on curtailment or settlement comprises any resulting change in the fair value of plan assets and any change in the present value of the defined benefit obligation.

(iii) Short-term employee benefits

Short-term employee benefit obligations are measured on an undiscounted basis and are expensed during the period in which employees render services. A liability is recognized for the amount expected to be paid under short-term cash bonus or profit-sharing plans if the Company has a present legal or constructive obligation to make such payments as a result of past service provided by the employees, and the obligation can be estimated reliably.

(q) Share-based payment

The grant-date fair value of equity-settled share-based payment arrangements granted to employees is generally recognized as an expense, with a corresponding increase in equity, over the vesting period of the awards. The amount recognized as an expense is adjusted to reflect the number of awards for which the related service and non-market performance conditions are expected to be met, such that the amount ultimately recognized is based on the number of awards that meet the related service and non-market performance conditions at the vesting date.

(r) Income taxes

Income taxes comprise current taxes and deferred taxes. All current and deferred taxes are recognized in profit or loss except for expenses related to business combinations or recognized directly in equity or other comprehensive income.

Current taxes comprise the expected tax payables or receivables on the taxable profits (losses) for the year and any adjustment to the tax payable or receivable in respect of previous years. The amount of current tax payables or receivables are the best estimate of the tax amount expected to be paid or received that reflects uncertainty related to income taxes, if any. It is measured using tax rates enacted or substantively enacted at the reporting date.

Deferred income taxes are recognized in respect of temporary differences between the carrying amounts of assets and liabilities for financial reporting purposes and their respective tax bases. Deferred taxes are not recognized for:

- (i) Temporary differences on the initial recognition of assets or liabilities in a transaction that is not a business combination and that affects neither accounting nor taxable profit (losses) at the time of transaction;

## FLYTECH TECHNOLOGY CO., LTD.

### Notes to the Financial Statements

- (ii) Temporary differences related to investments in subsidiaries, associates and joint arrangements to the extent that the Company is able to control the timing of the reversal of the temporary differences and it is probable that they will not reverse in the foreseeable future; and
- (iii) Taxable temporary differences arising on the initial recognition of goodwill.

Deferred taxes are measured at tax rates that are expected to be applied to temporary differences when they reverse, using tax rates enacted or substantively enacted at the reporting date, and reflect uncertainty related to income taxes, if any.

Deferred tax assets and liabilities are offset if the following criteria are met:

- (i) the Company has a legally enforceable right to set off current tax assets against current tax liabilities; and
- (ii) the deferred tax assets and the deferred tax liabilities relate to income taxes levied by the same taxation authority on either:
  - 1) the same taxable entity; or
  - 2) different taxable entities which intend to settle current tax assets and liabilities on a net basis, or to realize the assets and liabilities simultaneously, in each future period in which significant amounts of deferred tax liabilities or assets are expected to be settled or recovered.

Deferred tax assets are recognized for unused tax losses, tax credits, and deductible temporary differences to the extent that it is probable that future taxable profits will be available against which they can be utilized. Deferred tax assets are reviewed at each reporting date and reduced to the extent that it is no longer probable that the related tax benefit will be realized; such reductions are reversed when the probability of future taxable profits improves.

- (s) Earnings per share (“EPS”)

The basic and diluted EPS attributable to shareholders of the Company are disclosed in the parent-company-only financial statements. Basic EPS are calculated by dividing net income attributable to shareholders of the Company by the weighted-average number of common shares outstanding during the year. In calculating diluted EPS, the net income attributable to shareholders of the Company and weighted-average number of common shares outstanding during the year are adjusted for the effects of dilutive potential common shares. The Company’s dilutive potential common shares include profit sharing for employees to be settled in the form of common stock.

- (t) Operating segments

The Company discloses the operating segment information in the consolidated financial statements. Therefore, it does not disclose the operating segment information in the parent-company-only financial statements.

## FLYTECH TECHNOLOGY CO., LTD.

### Notes to the Financial Statements

#### 5. Critical accounting judgments and key sources of estimation uncertainty

The preparation of the parent-company-only financial statements in conformity with the Regulations and IFRSs endorsed by FSC requires management to make judgments, estimates and assumptions that affect the application of the accounting policies and the reported amount of assets, liabilities, income and expenses. Actual results may differ from these estimates. The estimates and underlying assumptions are reviewed on an ongoing basis. Revisions to accounting estimates are recognized in the period in which the estimates are revised and in the future periods affected.

There is no information involving critical judgments in applying the accounting policies in the parent-company-only financial statements.

Information about assumptions and estimation uncertainties that have a significant risk of resulting in a material adjustment within the next financial year is as follows:

(a) Valuation of inventory

Inventories are measured at the lower of cost or net realizable value, and the Company uses judgment and estimates to determine the net realizable value of inventory at each reporting date. Due to inventories are stated at the lower of cost or net realizable value, the Company estimates the net realizable value of inventory, taking into account of obsolescence and unmarketable items at the reporting date, and then writes down the cost of inventories to net realizable value. The net realizable value of the inventory is mainly determined based on assumptions of future demand within a specific time horizon, which could result in significant adjustments. Refer to note 6(e) for more details of the valuation of inventories.

(b) Impairment of goodwill

The entire carrying amount of investments in subsidiaries includes goodwill arising from initial recognition. The assessment of impairment of goodwill requires the Company to make subjective judgments to identify cash-generating units, allocate the goodwill to relevant cash-generating units, and estimate the recoverable amount of relevant cash-generating units. Any changes in these estimates based on changed economic conditions or business strategies could result in significant adjustments in future years. Refer to note 6(f) for more details of the impairment of goodwill.

#### 6. Significant account disclosures

(a) Cash and cash equivalents

|   | <b>December 31,<br/>2020</b> | <b>December<br/>31, 2019</b> |
|---|------------------------------|------------------------------|
| Cash on hand  | \$ 738                       | 774                          |
| Demand deposits and checking accounts                     | 1,826,910                    | 1,613,342                    |
| Time deposits with original maturities less than 3 months | 10,000                       | 10,000                       |
|   | <b>\$ 1,837,648</b>          | <b>1,624,116</b>             |

**FLYTECH TECHNOLOGY CO., LTD.**

**Notes to the Financial Statements**

- (b) Financial assets and liabilities at fair value through profit or loss — current

|  | <b>December 31,<br/>2020</b> | <b>December 31,<br/>2019</b> |
|--|------------------------------|------------------------------|
| Mandatorily measured at fair value through profit or loss: |                              |                              |
| Derivative instruments not used for hedging                |                              |                              |
| Foreign currency forward contracts                         | \$ 2,697                     | 120                          |
| Non-derivative financial assets                            |                              |                              |
| Convertible bonds  | 9,516                        | -                            |
|  | <b>\$ 12,213</b>             | <b>120</b>                   |
|  | <b>December 31,<br/>2020</b> | <b>December<br/>31, 2019</b> |
| Held for trading financial liabilities:                    |                              |                              |
| Foreign currency forward contracts                         | <b>\$ (444)</b>              | <b>(26)</b>                  |

Refer to note 6(q) for the detail of the changes in fair value recognized in profit or loss.

The Company entered into derivative contracts to manage its foreign currency exchange risk resulting from its operating activities. The derivative financial instruments that did not conform to the criteria for hedge accounting were classified as financial assets and liabilities at fair value through profit or loss:

| <b>December 31, 2020</b>   |     |  |                   |                        |
|--|-----|--|-------------------|------------------------|
|  |     | <b>Contract amount<br/>( in thousands)</b> | <b>Sell / Buy</b> | <b>Maturity period</b> |
| Financial assets — foreign<br>currency forward contracts         | USD | 12,000                                     | USD/NTD           | 2021.1.11~2021.3.10    |
| Financial liabilities — foreign<br>currency forward contracts    | GBP | 1,410                                      | GBP/NTD           | 2021.2.26~2021.4.29    |
| <b>December 31, 2019</b>   |     |  |                   |                        |
|  |     | <b>Contract amount<br/>( in thousands)</b> | <b>Sell / Buy</b> | <b>Maturity period</b> |
| Financial assets — foreign<br>currency forward contracts         | GBP | 1,400                                      | GBP/NTD           | 2020.1.31~2020.2.27    |
| Financial liabilities —<br>foreign currency forward<br>contracts | GBP | 650  | GBP/NTD           | 2020.1.31              |

- (c) Financial assets measured at amortised cost — current

|   | <b>December 31,<br/>2020</b> | <b>December<br/>31, 2019</b> |
|---|------------------------------|------------------------------|
| Time deposits with original maturities more than 3 months | <b>\$ -</b>                  | <b>149,900</b>               |

**FLYTECH TECHNOLOGY CO., LTD.**

**Notes to the Financial Statements**

The Company intended to hold to maturity in order to receive the contractual cash flows and the contractual cash flows were solely payments of principal and interest on the principal outstanding.

- (d) Notes and accounts receivable (including related parties), and other receivables

|  | <b>December 31,<br/>2020</b> | <b>December 31,<br/>2019</b> |
|--|------------------------------|------------------------------|
| Notes receivable – from operating activities           | \$ 4,879                     | 4,061                        |
| Accounts receivable – measured as amortized cost       | 441,682                      | 550,745                      |
| Less: loss allowance                                   | (8,299)                      | (8,299)                      |
|  | 438,262                      | 546,507                      |
| Accounts receivable from related parties               | 142,953                      | 132,562                      |
| Other receivables (classified as other current assets) | 172                          | 2,194                        |
|  | <b>\$ 581,387</b>            | <b>681,263</b>               |

The Company applies the simplified approach to provide for its expected credit losses, i.e. the use of life time expected loss provision for all receivables. To measure the expected credit losses, trade receivables have been based on shared credit risk characteristics and the days past due, as well as incorporated forward looking information. The loss allowance provision was determined as follows:

|                           | <b>December 31, 2020</b>         |  |   |
|---------------------------|----------------------------------|--|---|
|                           | <b>Gross carrying<br/>amount</b> | <b>Weighted-ave<br/>rage loss rate</b> | <b>Loss<br/>allowance<br/>provision</b> |
| Current                   | \$ 362,927                       | 1.33%                                  | 4,809                                   |
| Past due 0-30 days        | 81,243                           | 1.35%                                  | 1,099                                   |
| Past due 31-60 days       | 18                               | 100.00%                                | 18                                      |
| Past due 181 days or over | 2,373                            | 100.00%                                | 2,373                                   |
|                           | <b>\$ 446,561</b>                |  | <b>8,299</b>                            |
|                           | <b>December 31, 2019</b>         |  |   |
|                           | <b>Gross carrying<br/>amount</b> | <b>Weighted-ave<br/>rage loss rate</b> | <b>Loss<br/>allowance<br/>provision</b> |
| Current                   | \$ 424,962                       | 0.04%                                  | 166                                     |
| Past due 0-30 days        | 78,776                           | 1.45%                                  | 1,141                                   |
| Past due 31-60 days       | 51,068                           | 13.69%                                 | 6,992                                   |
|                           | <b>\$ 554,806</b>                |  | <b>8,299</b>                            |

There were no loss allowance provision for accounts receivable from related parties after the assessment.



**FLYTECH TECHNOLOGY CO., LTD.**

**Notes to the Financial Statements**

Movements of the loss allowance for notes and accounts receivable were as follows:

|   | <b>2020</b>     | <b>2019</b>  |
|---|-----------------|--------------|
| Balance at January 1, 2020 (also as the balance at December 31, 2020) | <b>\$ 8,299</b> | <b>8,299</b> |

(e) Inventories

(i) The information of inventories was as follows:

|                 | <b>December 31,<br/>2020</b> | <b>December<br/>31, 2019</b> |
|-----------------|------------------------------|------------------------------|
| Raw materials   | \$ 226,971                   | 204,398                      |
| Work in process | 137,791                      | 119,423                      |
| Finished goods  | 21,798                       | 48,960                       |
|                 | <b>\$ 386,560</b>            | <b>372,781</b>               |

(ii) The amounts of inventories recognized as cost of revenue were as follows:

|                                | <b>2020</b>         | <b>2019</b>      |
|--------------------------------|---------------------|------------------|
| Costs of inventories sold      | \$ 2,117,095        | 2,527,840        |
| Losses on scrap in inventories | 18,062              | 21,779           |
| Transfer for repairment costs  | 3,531               | 7,954            |
|                                | <b>\$ 2,138,688</b> | <b>2,557,573</b> |

(f) Investments accounted for using equity method

|              | <b>December 31,<br/>2020</b> | <b>December<br/>31, 2019</b> |
|--------------|------------------------------|------------------------------|
| Subsidiaries | <b>\$ 1,086,722</b>          | <b>1,111,662</b>             |

(i) Please refer to the consolidated financial statements for the year ended December 31, 2020.

(ii) Impairment test on goodwill

At the end of each reporting period, the carrying amount of goodwill included in the investments in subsidiaries is tested for impairment. No impairment losses were recognized. Please refer to the consolidated financial statements for the year ended December 31, 2020.

**FLYTECH TECHNOLOGY CO., LTD.**

**Notes to the Financial Statements**

(g) Property, plant and equipment

|                              | Land              | Buildings      | Machinery      | Mold<br>equipment | Furniture<br>and<br>fixtures | Other<br>equipment | Construction<br>in progress | Total            |
|------------------------------|-------------------|----------------|----------------|-------------------|------------------------------|--------------------|-----------------------------|------------------|
| Cost:                        |                   |                |                |                   |                              |                    |                             |                  |
| Balance at January 1, 2020   | \$ 319,238        | 729,469        | 291,315        | 424,570           | 50,503                       | 17,580             | -                           | 1,832,675        |
| Additions                    | -                 | 2,318          | 4,142          | 36,822            | 1,125                        | -                  | -                           | 44,407           |
| Reclassification             | -                 | -              | -              | 267               | -                            | -                  | -                           | 267              |
| Disposals                    | -                 | -              | (2,997)        | -                 | (106)                        | (2,000)            | -                           | (5,103)          |
| Balance at December 31, 2020 | <u>\$ 319,238</u> | <u>731,787</u> | <u>292,460</u> | <u>461,659</u>    | <u>51,522</u>                | <u>15,580</u>      | <u>-</u>                    | <u>1,872,246</u> |
| Balance at January 1, 2019   | \$ 382,446        | 613,347        | 284,239        | 390,728           | 48,189                       | 17,580             | 41,887                      | 1,778,416        |
| Additions                    | -                 | -              | 7,076          | 29,088            | 2,314                        | -                  | 11,027                      | 49,505           |
| Reclassification             | (63,208)          | 116,122        | -              | 4,754             | -                            | -                  | (52,914)                    | 4,754            |
| Balance at December 31, 2019 | <u>\$ 319,238</u> | <u>729,469</u> | <u>291,315</u> | <u>424,570</u>    | <u>50,503</u>                | <u>17,580</u>      | <u>-</u>                    | <u>1,832,675</u> |
| Accumulated depreciation:    |                   |                |                |                   |                              |                    |                             |                  |
| Balance at January 1, 2020   | \$ -              | 142,045        | 202,236        | 355,468           | 36,975                       | 13,357             | -                           | 750,081          |
| Depreciation                 | -                 | 16,649         | 19,972         | 36,256            | 4,196                        | 931                | -                           | 78,004           |
| Disposals                    | -                 | -              | (2,997)        | -                 | (106)                        | (1,444)            | -                           | (4,547)          |
| Balance at December 31, 2020 | <u>\$ -</u>       | <u>158,694</u> | <u>219,211</u> | <u>391,724</u>    | <u>41,065</u>                | <u>12,844</u>      | <u>-</u>                    | <u>823,538</u>   |
| Balance at January 1, 2019   | \$ -              | 128,078        | 180,698        | 316,511           | 32,487                       | 12,022             | -                           | 669,796          |
| Depreciation                 | -                 | 13,967         | 21,538         | 38,957            | 4,488                        | 1,335              | -                           | 80,285           |
| Balance at December 31, 2019 | <u>\$ -</u>       | <u>142,045</u> | <u>202,236</u> | <u>355,468</u>    | <u>36,975</u>                | <u>13,357</u>      | <u>-</u>                    | <u>750,081</u>   |
| Carrying amount:             |                   |                |                |                   |                              |                    |                             |                  |
| Balance at December 31, 2020 | <u>\$ 319,238</u> | <u>573,093</u> | <u>73,249</u>  | <u>69,935</u>     | <u>10,457</u>                | <u>2,736</u>       | <u>-</u>                    | <u>1,048,708</u> |
| Balance at December 31, 2019 | <u>\$ 319,238</u> | <u>587,424</u> | <u>89,079</u>  | <u>69,102</u>     | <u>13,528</u>                | <u>4,223</u>       | <u>-</u>                    | <u>1,082,594</u> |
| Balance at January 1, 2019   | <u>\$ 382,446</u> | <u>485,269</u> | <u>103,541</u> | <u>74,217</u>     | <u>15,702</u>                | <u>5,558</u>       | <u>41,887</u>               | <u>1,108,620</u> |

(h) Right-of-use assets

|   | Other<br>equipment |
|---|--------------------|
| Cost:   |                    |
| Balance at January 1, 2020 (also as the balance at December 31, 2020) | <u>\$ 3,583</u>    |
| Balance at January 1, 2019  | \$ 926             |
| Additions   | <u>2,657</u>       |
| Balance at December 31, 2019  | <u>\$ 3,583</u>    |
| Accumulated depreciation:   |                    |
| Balance at January 1, 2020  | \$ 983             |
| Depreciation  | <u>1,040</u>       |
| Balance at December 31, 2020  | <u>\$ 2,023</u>    |
| Balance at January 1, 2019  | \$ -               |
| Depreciation  | <u>983</u>         |
| Balance at December 31, 2019  | <u>983</u>         |
| Carrying amount:  |                    |
| Balance at December 31, 2020  | <u>\$ 1,560</u>    |
| Balance at December 31, 2019  | <u>\$ 2,600</u>    |
| Balance at January 1, 2019  | <u>\$ 926</u>      |

**FLYTECH TECHNOLOGY CO., LTD.**

**Notes to the Financial Statements**

(i) Lease liabilities

|             | <b>December 31,<br/>2020</b> | <b>December 31,<br/>2019</b> |
|-------------|------------------------------|------------------------------|
| Current     | <u>\$ 1,049</u>              | <u>1,032</u>                 |
| Non-current | <u>\$ 532</u>                | <u>1,581</u>                 |

For the maturity analysis, please refer to note 6(s).

The amounts recognized in profit or loss were as follows:

|   | <b>2020</b>  | <b>2019</b> |
|---|--------------|-------------|
| Interest on lease liabilities                   | <u>\$ 35</u> | <u>30</u>   |
| Expenses relating to leases of low-value assets | <u>\$ 34</u> | <u>17</u>   |

The amounts recognized in the statement of cash flows for the Company was as follows:

|                               | <b>2020</b>     | <b>2019</b>  |
|-------------------------------|-----------------|--------------|
| Total cash outflow for leases | <u>\$ 1,101</u> | <u>1,017</u> |

The Company lease other equipment, with lease terms of three years. These leases are short-term or low-value assets, the Company apply the exemption and not to recognize right-of-use assets and lease liabilities for these leases.

(j) Provision for warranties

|                        | <b>2020</b>     | <b>2019</b>    |
|------------------------|-----------------|----------------|
| Balance at January 1   | \$ 10,646       | 12,735         |
| Provisions made        | 2,229           | 2,898          |
| Amount utilized        | <u>(4,175)</u>  | <u>(4,987)</u> |
| Balance at December 31 | <u>\$ 8,700</u> | <u>10,646</u>  |

The provision for warranties is estimated based on historical warranty data associated with similar products. The Company expects to settle most of the warranty liability in one to three years from the date of the sale of the product.

**FLYTECH TECHNOLOGY CO., LTD.**

**Notes to the Financial Statements**

(k) Employee benefits

(i) Defined benefit plans

The present value of defined benefit obligations and the fair value of plan assets were as follows:

|                                      | <b>December 31,<br/>2020</b> | <b>December 31,<br/>2019</b> |
|--------------------------------------|------------------------------|------------------------------|
| Present value of benefit obligations | \$ 44,329                    | 52,083                       |
| Fair value of plan assets            | <u>(25,252)</u>              | <u>(28,983)</u>              |
| Net defined benefit liabilities      | <b><u>\$ 19,077</u></b>      | <b><u>23,100</u></b>         |

The Company makes defined benefit plan contributions to the pension fund account at Bank of Taiwan that provides pension benefits for employees upon retirement. The plans (covered by the Labor Standards Law) entitle a retired employee to receive a payment based on years of service and average salary for the six months prior to the employee's retirement.

1) Composition of plan assets

The pension fund (the "Fund") contributed by the Company is managed and administered by the Bureau of Labor Funds of the Ministry of Labor (the Bureau of Labor Funds). According to the Regulations for Revenues, Expenditures, Safeguard and Utilization of the Labor Retirement Fund, with regard to the utilization of the Fund, minimum earnings shall be no less than the earnings attainable from two-year time deposits with interest rates offered by local banks.

As of December 31, 2020 and 2019, the Company's labor pension fund account balance at Bank of Taiwan amounted to \$25,252 and \$28,983, respectively. Refer to the website of the Bureau of Labor Funds for information on the labor pension fund assets including the asset portfolio and yield of the fund.

2) Movements in present value of defined benefit obligations

|   | <b>2020</b>             | <b>2019</b>          |
|---|-------------------------|----------------------|
| Defined benefit obligations at January 1                      | \$ 52,083               | 53,338               |
| Current service costs and interest expense                    | 659                     | 917                  |
| Remeasurement of net defined benefit liabilities:             |                         |                      |
| –Actuarial loss arising from changes in financial assumptions | 626                     | 234                  |
| Benefits paid by plan - by the Company                        | (1,000)                 | -                    |
| Benefits paid by plan - by the plan assets                    | <u>(8,039)</u>          | <u>(2,406)</u>       |
| Defined benefit obligations at December 31                    | <b><u>\$ 44,329</u></b> | <b><u>52,083</u></b> |

**FLYTECH TECHNOLOGY CO., LTD.**

**Notes to the Financial Statements**

3) Movements of fair value of plan assets

|   | <b>2020</b>      | <b>2019</b>   |
|---|------------------|---------------|
| Fair value of plan assets at January 1                      | \$ 28,983        | 27,351        |
| Interest income   | 293              | 304           |
| Remeasurement on net defined benefit liabilities:           |                  |               |
| –Return on plan assets (excluding current interest expense) | 867              | 975           |
| Contributions by plan participants                          | 3,148            | 2,759         |
| Benefits paid by the plan                                   | (8,039)          | (2,406)       |
| Fair value of plan assets at December 31                    | <b>\$ 25,252</b> | <b>28,983</b> |

4) Changes in the effect of the asset ceiling

In 2020 and 2019, there was no effect of the asset ceiling.

5) Expenses recognized in profit or loss

|                      | <b>2020</b>   | <b>2019</b> |
|----------------------|---------------|-------------|
| Current service cost | \$ 138        | 331         |
| Net interest expense | 228           | 282         |
|                      | <b>\$ 366</b> | <b>613</b>  |
| Operating expenses   | <b>\$ 366</b> | <b>613</b>  |

6) Actuarial assumptions

The principal assumptions of the actuarial valuation were as follows:

|                              | <b>December 31,<br/>2020</b> | <b>December 31,<br/>2019</b> |
|------------------------------|------------------------------|------------------------------|
| Discount rate                | 0.75%                        | 1.00%                        |
| Future salary increases rate | 2.00%                        | 2.00%                        |

The weighted-average duration of the defined benefit plans was 12.2 years. The Company expects to make contribution of \$360 to the defined benefit plans in the year following December 31, 2020.

7) Sensitivity analysis

When calculating the present value of the defined benefit obligations, the Company uses judgments and estimations to determine the actuarial assumptions for each measurement date, including discount rates and future salary changes. Any changes in the actuarial assumptions may significantly impact the amount of the defined benefit obligations.

## FLYTECH TECHNOLOGY CO., LTD.

### Notes to the Financial Statements

The following table summarizes the impact of a change in the assumptions on the present value of the defined benefit obligation:

|                              | <b>Impact on defined benefit obligation</b> |                       |
|------------------------------|---|-----------------------|
|                              | <u>0.25% Increase</u>                       | <u>0.25% Decrease</u> |
| Balance at December 31, 2020 |   |                       |
| Discount rate                | (807)                                       | 838                   |
| Future salary                | 867   | (763)                 |
| Balance at December 31, 2019 |   |                       |
| Discount rate                | (883)                                       | 919                   |
| Future salary                | 958   | (837)                 |

Each sensitivity analysis considers the change in one assumption at a time, leaving the other assumptions unchanged. This approach shows the isolated effect of changing one individual assumption but does not take into account that some assumptions are related. The method used to carry out the sensitivity analysis is the same as the calculation of the net defined benefit liabilities recognized in the balance sheets. The method used to carry out the sensitivity analysis is the same as in the prior year.

(ii) Defined contribution plans

The Company contribute monthly an amount equal to 6% of each employee's monthly wages to the employee's individual pension fund account at the Bureau of Labor Insurance in accordance with the provisions of the Labor Pension Act. Under this defined contribution plans, the Company has no legal or constructive obligation to pay additional amounts after contributing a fixed amount.

The Company recognized expense of the defined contribution plans were as follow:

|                    | <u>2020</u>             | <u>2019</u>          |
|--------------------|-------------------------|----------------------|
| Cost of revenue    | \$ 4,218                | 4,510                |
| Operating expenses | 8,949                   | 8,454                |
|                    | <u><b>\$ 13,167</b></u> | <u><b>12,964</b></u> |

(l) Income taxes

(i) The components of income tax expense were as follows:

|   | <u>2020</u>              | <u>2019</u>           |
|---|--------------------------|-----------------------|
| Current income tax expense                        |                          |                       |
| Current period                                    | \$ 130,397               | 152,470               |
| Adjustments for prior years                       | (3,695)                  | (3,173)               |
| Deferred tax benefit                              |                          |                       |
| Origination and reversal of temporary differences | 9,553                    | (2,723)               |
| Income tax expense                                | <u><b>\$ 136,255</b></u> | <u><b>146,574</b></u> |

**FLYTECH TECHNOLOGY CO., LTD.**

**Notes to the Financial Statements**

The Company's income tax expenses recognized in other comprehensive income were as follows:

|  | <b>2020</b>           | <b>2019</b>         |
|--|-----------------------|---------------------|
| Items that will not be reclassified to profit or loss: |                       |                     |
| Remeasurement of defined benefit plans                 | <u><u>\$ (48)</u></u> | <u><u>(148)</u></u> |

The reconciliation of the expected income tax expense calculated based on the R.O.C. statutory tax rate and the actual income tax expense reported in the parent-company-only statements of comprehensive income were as follows:

|   | <b>2020</b>              | <b>2019</b>           |
|---|--------------------------|-----------------------|
| Income before income tax                          | <u><u>\$ 725,899</u></u> | <u><u>883,096</u></u> |
| Income tax using the Company's statutory tax rate | \$ 145,180               | 176,619               |
| Tax-exempt income                                 | (2,881)                  | (34,077)              |
| Investment tax credits                            | (11,250)                 | (872)                 |
| Changes in unrecognized temporary differences     | 4,823                    | 4,357                 |
| Adjustments for prior years                       | (3,695)                  | (3,173)               |
| Undistributed earnings additional tax             | <u>4,078</u>             | <u>3,720</u>          |
|   | <u><u>\$ 136,255</u></u> | <u><u>146,574</u></u> |

(ii) Deferred income tax assets and liabilities

1) Unrecognized deferred income tax assets

As the Company is able to control the timing of the reversal of temporary differences associated with the loss on its investments in its subsidiaries, and concludes that the temporary differences will not reverse in the foreseeable future, such temporary differences were not recognized as deferred income tax assets.

|   | <b>December 31,<br/>2020</b> | <b>December 31,<br/>2019</b> |
|---|------------------------------|------------------------------|
| Loss related to investments in subsidiaries | <u><u>\$ 13,463</u></u>      | <u><u>9,347</u></u>          |

2) Recognized deferred income tax assets and liabilities

Deferred income tax assets:

|  | <b>Defined<br/>benefit plans</b> | <b>Inventory<br/>provisions</b> | <b>Others</b>        | <b>Total</b>         |
|--|----------------------------------|---------------------------------|----------------------|----------------------|
| <b>Balance at January 1, 2020</b>                  | \$ 5,067                         | 6,500                           | 21,959               | 33,526               |
| Recognized in profit or loss                       | (757)                            | -                               | (6,554)              | (7,311)              |
| Recognized in other comprehensive income<br>(loss) | <u>(48)</u>                      | <u>-</u>                        | <u>-</u>             | <u>(48)</u>          |
| <b>Balance at December 31, 2020</b>                | <u><u>\$ 4,262</u></u>           | <u><u>6,500</u></u>             | <u><u>15,405</u></u> | <u><u>26,167</u></u> |
| <b>Balance at January 1, 2019</b>                  | \$ 5,644                         | 6,500                           | 15,620               | 27,764               |
| Recognized in profit or loss                       | (429)                            | -                               | 6,339                | 5,910                |
| Recognized in other comprehensive income<br>(loss) | <u>(148)</u>                     | <u>-</u>                        | <u>-</u>             | <u>(148)</u>         |
| <b>Balance at December 31, 2019</b>                | <u><u>\$ 5,067</u></u>           | <u><u>6,500</u></u>             | <u><u>21,959</u></u> | <u><u>33,526</u></u> |

**FLYTECH TECHNOLOGY CO., LTD.**

**Notes to the Financial Statements**

Deferred income tax liabilities:

|                                     | <b>Unremitted<br/>earnings<br/>from<br/>subsidiaries</b> | <b>Others</b> | <b>Total</b>  |
|-------------------------------------|--|---------------|---------------|
| <b>Balance at January 1, 2020</b>   | \$ 30,434  | 388           | 30,822        |
| Recognized in profit or loss        | 1,815  | 427           | 2,242         |
| <b>Balance at December 31, 2020</b> | <b>\$ 32,249</b>   | <b>815</b>    | <b>33,064</b> |
| <b>Balance at January 1, 2019</b>   | \$ 27,154  | 481           | 27,635        |
| Recognized in profit or loss        | 3,280  | (93)          | 3,187         |
| <b>Balance at December 31, 2019</b> | <b>\$ 30,434</b>   | <b>388</b>    | <b>30,822</b> |

(iii) The Tax Authority has examined the Company's income tax returns through 2017 expect for 2016.

(m) Capital and other equity

(i) Common stock

As of December 31, 2020 and 2019, the Company's authorized shares of common stock consisted of 220,000 thousand shares and 180,000 thousand shares, respectively, with par value of \$10 (dollars) per share, both of which 143,062 thousand shares were issued and outstanding.

(ii) Capital surplus

|  | <b>December 31,<br/>2020</b> | <b>December 31,<br/>2019</b> |
|--|------------------------------|------------------------------|
| Premium derived from the issuance of share in excess of par value:   |                              |                              |
| Premium on common stock issued for conversion of convertible bonds   | \$ 593,692                   | 665,223                      |
| Forfeited employee stock options   | 2,433                        | 2,433                        |
| Difference between the consideration and the carrying amounts arising from the acquisition or disposal of shares in subsidiaries | 982                          | 982                          |
| Changes in ownership interest in subsidiaries  | -                            | 5,594                        |
| Gain on disposal of assets   | 15                           | 15                           |
|  | <b>\$ 597,122</b>            | <b>674,247</b>               |



## FLYTECH TECHNOLOGY CO., LTD.

### Notes to the Financial Statements

Pursuant to the Company Act, any realized capital surplus is initially used to cover an accumulated deficit, and the balance, if any, could be transferred to common stock dividends or dividends as cash dividends based on the original shareholding ratio. Realized capital surplus includes the premium derived from the issuance of shares in excess of par value and donations from stockholders received by the Company. In accordance with the Regulations Governing the Offering and Issuance of Securities by Securities Issuers, distribution of stock dividends from capital surplus in any one year shall not exceed 10% of paid-in capital.

(iii) Retained earnings and dividend policy

The Company's Articles of Incorporation stipulate that at least 10% of annual net income after deducting an accumulated deficit, if any, must be retained as a legal reserve until such retention equals the amount of paid-in capital. In addition, a special reserve should be set aside in accordance with applicable laws and regulations. The remaining balance of annual net income, together with the unappropriated earnings from the previous years, should be distributed according to the proposal by the board of directors to be approved in the shareholders' meeting. Appropriation of earnings should not be less than 60% of the net income after deducting an accumulated deficit, legal reserve, and special reserve.

In accordance with Ruling No. 1010012865 issued by the Financial Supervisory Commission on April 6, 2012, a special reserve equal to the total amount of items that were accounted for as deductions from stockholders' equity was set aside from current and prior-year earnings. This special reserve shall revert to the retained earnings and be made available for distribution when the items that are accounted for as deductions from stockholders' equity are reversed in subsequent periods.

In view of the overall economic environment and the development of the industry, and in order to meet the Company's long-term financial planning and cash requirements of stockholders, the Company has adopted a stable dividend policy in which a cash dividend comprises at least 10% of total distribution of dividends.

The distribution of earnings for 2019 and 2018 had been approved in the meetings of shareholders held on June 10, 2020, and June 12, 2019, respectively. The relevant dividend distributions to shareholders were as follows:

|  | <b>2019</b>                                     |                         | <b>2018</b>                                     |                         |
|--|---|-------------------------|---|-------------------------|
|  | <b>Dividends<br/>per share<br/>(in dollars)</b> | <b>Total<br/>amount</b> | <b>Dividends<br/>per share<br/>(in dollars)</b> | <b>Total<br/>amount</b> |
| Dividends distributed to shareholders: |   |                         |   |                         |
| Cash                                   | \$ 4.00   | <b>572,249</b>          | 4.50  | <b>643,780</b>          |

## FLYTECH TECHNOLOGY CO., LTD.

### Notes to the Financial Statements

On June 10, 2020 and June 12, 2019, the Company's shareholders decided to distribute cash of \$0.5 dollars per share from capital surplus for both years. Total distributed cash dividend for 2019 and 2018 are \$4.5 and \$5.0 per share, respectively.

(iv) Other equity items (net after tax)

|  | Foreign<br>currency<br>translation<br>differences | Remeasureme<br>nt of defined<br>benefit plans | Total           |
|--|---|---|-----------------|
| Balance at January 1, 2020   | \$ (43,189)                                       | (6,213)                                       | (49,402)        |
| Exchange differences on subsidiaries<br>accounted for using equity method<br>(net of tax)      | (7,753)   | -   | (7,753)         |
| Remeasurement of defined benefit<br>plans (net of tax)   | -   | 193   | 193             |
| Remeasurement of defined benefit<br>plans on subsidiaries accounted for<br>using equity method | -   | (977)   | (977)           |
| Balance at December 31, 2020   | <u>\$ (50,942)</u>                                | <u>(6,997)</u>                                | <u>(57,939)</u> |
| Balance at January 1, 2019   | \$ (35,732)                                       | (4,612)                                       | (40,344)        |
| Exchange differences on subsidiaries<br>accounted for using equity method<br>(net of tax)      | (7,457)   | -   | (7,457)         |
| Remeasurement of defined benefit<br>plans (net of tax)   | -   | 593   | 593             |
| Remeasurement of defined benefit<br>plans on subsidiaries accounted for<br>using equity method | -   | (2,194)                                       | (2,194)         |
| Balance at December 31, 2019   | <u>\$ (43,189)</u>                                | <u>(6,213)</u>                                | <u>(49,402)</u> |

(n) Earnings per share ("EPS")

(i) Basic EPS

|   | 2020           | 2019        |
|---|----------------|-------------|
| Profit attributable to shareholders of the Company                          | \$ 589,644     | 736,522     |
| Weighted-average number of ordinary shares<br>outstanding<br>(in thousands) | 143,062        | 143,062     |
| Basic EPS (dollars)   | <u>\$ 4.12</u> | <u>5.15</u> |

**FLYTECH TECHNOLOGY CO., LTD.**

**Notes to the Financial Statements**

(ii) Diluted EPS

|   | <b>2020</b>    | <b>2019</b> |
|---|----------------|-------------|
| Profit attributable to shareholders of the Company (diluted)  | \$ 589,644     | 736,522     |
| Weighted-average number of ordinary shares outstanding (in thousands)   | 143,062        | 143,062     |
| Effect of employee bonuses  | 1,115          | 1,295       |
| Weighted-average number of ordinary shares outstanding (in thousands) (including effect of dilutive potential common stock) | 144,177        | 144,357     |
| Diluted EPS (dollars)   | <b>\$ 4.09</b> | <b>5.10</b> |

(o) Revenue from contracts with customers

(i) Disaggregation of revenue

|                               | <b>2020</b>         | <b>2019</b>      |
|-------------------------------|---------------------|------------------|
| Primary geographical markets: |                     |                  |
| Domestic sales                | \$ 404,459          | 300,982          |
| Export:                       |                     |                  |
| Asia                          | 297,801             | 401,848          |
| America                       | 1,634,296           | 1,936,531        |
| Europe and Africa             | 942,177             | 1,287,372        |
|                               | 2,874,274           | 3,625,751        |
|                               | <b>\$ 3,278,733</b> | <b>3,926,733</b> |
| Major products:               |                     |                  |
| Industrial computers          | \$ 2,901,451        | 3,434,820        |
| Peripherals                   | 353,478             | 468,312          |
| Others                        | 23,804              | 23,601           |
|                               | <b>\$ 3,278,733</b> | <b>3,926,733</b> |

(ii) Contract balances

|   | <b>December 31,<br/>2020</b> | <b>December 31,<br/>2019</b> | <b>January 1,<br/>2019</b> |
|---|------------------------------|------------------------------|----------------------------|
| Notes and accounts receivable (including related parties)         | \$ 589,514                   | 687,368                      | 761,014                    |
| Less: loss allowance  | (8,299)                      | (8,299)                      | (8,299)                    |
|   | <b>\$ 581,215</b>            | <b>679,069</b>               | <b>752,715</b>             |
| Contract liabilities (classified under other current liabilities) | <b>\$ 17,771</b>             | <b>11,765</b>                | <b>18,775</b>              |

## FLYTECH TECHNOLOGY CO., LTD.

### Notes to the Financial Statements

Please refer to note 6(d) for details on notes and accounts receivable and its loss allowance.

The amount of revenue recognized for the year ended December 31, 2020 and 2019, that was included in the contract liability balance at the beginning of period were \$7,266 and \$15,606, respectively.

(p) Remuneration of employees and directors and supervisors

Pursuant to the Company's articles of incorporation, the Company shall distribute 3% to 15% of its profits in the current period as compensation to its employees and no more than 3% to its directors and supervisors. Nevertheless, the profits in the current period should be reserved for offsetting the accumulated deficit, if any, prior to distributing the compensation to the employees and directors and supervisors. The aforementioned compensation of employees could be distributed in the form of cash or stock to the employees of the Company's subsidiaries conforming to certain requirements.

For the year ended December 31, 2020 and 2019, the Company accrued the remuneration to its employees amounting to \$51,500 and \$77,000, respectively, and the remuneration to its directors amounting to \$3,500 for both years, which were calculated based on the net profits before tax of each period (excluding the remuneration to employees and directors), multiplied by the distribution ratio of remuneration to employees and directors under the Company's articles of incorporation, and recognized as cost of revenue and operating expenses. If the actual amounts differ from the estimated amounts, the differences shall be accounted as changes in accounting estimates and recognized as profit or loss in following year. The abovementioned estimated remuneration to employees, directors and supervisors is the same as the amount approved by the Board of Directors and will be paid in cash. The related information would be available at the Market Observation Post System website.

(q) Non-operating income and loss

(i) Interest income

|                                    | <u>2020</u>     | <u>2019</u>   |
|------------------------------------|-----------------|---------------|
| Interest income from bank deposits | <u>\$ 6,483</u> | <u>11,381</u> |

(ii) Other income

|                   | <u>2020</u>      | <u>2019</u>  |
|-------------------|------------------|--------------|
| Government grants | \$ 16,502        | -            |
| Others            | <u>1,377</u>     | <u>1,450</u> |
|                   | <u>\$ 17,879</u> | <u>1,450</u> |

**FLYTECH TECHNOLOGY CO., LTD.**

**Notes to the Financial Statements**

(iii) Other gains and losses

|  | <b>2020</b>       | <b>2019</b>     |
|--|-------------------|-----------------|
| Gain (Loss) on financial assets and liabilities at fair value through profit or loss | \$ 1,675          | (650)           |
| Foreign currency exchange loss   | (11,017)          | (40,360)        |
| Loss on disposal of property, plant and equipment                                    | (287)             | -               |
| Others   | 375               | (40)            |
|  | <b>\$ (9,254)</b> | <b>(41,050)</b> |

(iv) Finance costs

|   | <b>2020</b>  | <b>2019</b> |
|---|--------------|-------------|
| Interest expense from lease liabilities | <b>\$ 35</b> | <b>30</b>   |

(r) Categories and fair value of financial instruments

(i) Categories of financial instruments

1) Financial assets

|   | <b>December 31,<br/>2020</b> | <b>December<br/>31, 2019</b> |
|---|------------------------------|------------------------------|
| Financial assets at fair value through profit or loss:  |                              |                              |
| Financial assets mandatorily measured at fair value through profit or loss – foreign currency forward contracts | <b>\$ 12,213</b>             | <b>120</b>                   |
| Financial assets measured at amortized cost:  |                              |                              |
| Cash and cash equivalents   | \$ 1,837,648                 | 1,624,116                    |
| Financial assets measured at amortized cost–current   | -                            | 149,900                      |
| Notes and accounts receivable (including related parties)   | 581,215                      | 679,069                      |
| Other receivables (classified as other current assets)  | 172                          | 2,194                        |
| Other financial assets – current (classified as other current assets)   | 226                          | 224                          |
| Other financial assets – non-current  | 285                          | 285                          |
|   | <b>\$ 2,419,546</b>          | <b>2,455,788</b>             |

**FLYTECH TECHNOLOGY CO., LTD.**

**Notes to the Financial Statements**

2) Financial liabilities

|   | <b>December 31,<br/>2020</b> | <b>December<br/>31, 2019</b> |
|---|------------------------------|------------------------------|
| Financial liabilities at fair value through profit or loss :                |                              |                              |
| Financial liabilities held-for-trading – foreign currency forward contracts | <b><u>\$ 444</u></b>         | <b><u>26</u></b>             |
| Financial liabilities measured at amortized cost:                           |                              |                              |
| Notes and accounts payable (including related parties)                      | \$ 202,306                   | 288,875                      |
| Lease liabilities (including non-current)                                   | 1,581                        | 2,613                        |
| Other payables  | <u>186,296</u>               | <u>199,789</u>               |
|   | <b><u>\$ 390,183</u></b>     | <b><u>491,277</u></b>        |

(ii) Fair value information—financial instruments not measured at fair value

The Company considers that the carrying amounts of financial assets and financial liabilities measured at amortized cost approximate their fair values.

(iii) Financial instruments that are measured at fair value

The table below analyzes financial instruments that are measured at fair value subsequent to initial recognition, grouped into Levels 1 to 3 based on the degree to which the fair value is observable. The different levels have been defined as follows:

- 1) Level 1: quoted prices (unadjusted) in active markets for identified assets or liabilities.
- 2) Level 2: inputs other than quoted prices included within Level 1 that are observable for the asset or liability, either directly (i.e., as prices) or indirectly (i.e., derived from prices).
- 3) Level 3: inputs for the assets or liabilities that are not based on observable market data (unobservable inputs).

**FLYTECH TECHNOLOGY CO., LTD.**

**Notes to the Financial Statements**

|   |           | December 31, 2020    |                 |                     |                     |                      |
|---|-----------|----------------------|-----------------|---------------------|---------------------|----------------------|
|   |           | Carrying             | Fair Value      |                     |                     |                      |
|   |           | Amount               | Level 1         | Level 2             | Level 3             | Total                |
| Financial assets mandatorily measured at fair value through profit or loss:       |           |                      |                 |                     |                     |                      |
| Foreign currency forward contracts  |           |                      |                 |                     |                     |                      |
|   | \$        | 2,697                | -               | 2,697               | -                   | 2,697                |
| Convertible bonds   |           |                      |                 |                     |                     |                      |
|   |           | <u>9,516</u>         | <u>-</u>        | <u>-</u>            | <u>9,516</u>        | <u>9,516</u>         |
|   | <b>\$</b> | <b><u>12,213</u></b> | <b><u>-</u></b> | <b><u>2,697</u></b> | <b><u>9,516</u></b> | <b><u>12,213</u></b> |
| Financial liabilities mandatorily measured at fair value through profit or loss:  |           |                      |                 |                     |                     |                      |
| Foreign currency forward contracts  |           |                      |                 |                     |                     |                      |
|   | <b>\$</b> | <b><u>444</u></b>    | <b><u>-</u></b> | <b><u>444</u></b>   | <b><u>-</u></b>     | <b><u>444</u></b>    |
|   |           | December 31, 2019    |                 |                     |                     |                      |
|   |           | Carrying             | Fair Value      |                     |                     |                      |
|   |           | Amount               | Level 1         | Level 2             | Level 3             | Total                |
| Financial assets mandatorily measured at fair value through profit or loss:       |           |                      |                 |                     |                     |                      |
| Foreign currency forward contracts  |           |                      |                 |                     |                     |                      |
|   | <b>\$</b> | <b><u>120</u></b>    | <b><u>-</u></b> | <b><u>120</u></b>   | <b><u>-</u></b>     | <b><u>120</u></b>    |
| Financial liabilities mandatorily measured at fair value through profit or loss : |           |                      |                 |                     |                     |                      |
| Foreign currency forward contracts  |           |                      |                 |                     |                     |                      |
|   | <b>\$</b> | <b><u>26</u></b>     | <b><u>-</u></b> | <b><u>26</u></b>    | <b><u>-</u></b>     | <b><u>26</u></b>     |

There were no transfers between fair value levels for the years ended December 31, 2020 and 2019.

Movement in financial assets included Level 3 fair value hierarchy:

|                        | 2020                   | 2019            |
|------------------------|------------------------|-----------------|
| Balance at January 1   | \$ -                   | -               |
| Additions              | 10,000                 | -               |
| Recognized in loss     | <u>(484)</u>           | <u>-</u>        |
| Balance at December 31 | <b><u>\$ 9,516</u></b> | <b><u>-</u></b> |

## FLYTECH TECHNOLOGY CO., LTD.

### Notes to the Financial Statements

(iv) Valuation techniques and assumptions used in fair value measurement

1) Non-derivative financial instruments

A financial instrument is regarded as being quoted in an active market if quoted prices are readily available. For unquoted equity instruments which cannot be transferred freely in public market, their fair values are determined by using the valuation techniques adopted by the Corporation based on the information from the Market Observation Post System, the Taiwan Stock Exchange, etc. and calculated by using the Black-Scholes Model. The Company uses the quoted market prices and the price-book ratios of similar publicly traded companies into consideration by using the market comparison approach. The estimates had been adjusted by the depreciation from lack of market liquidity.

2) Derivative financial instruments

The fair value of foreign currency forward contracts is computed individually by each contract using the valuation technique.

(s) Financial risk management

The Company is exposed to credit risk, liquidity risk, and market risk (including currency risk and interest rate risk). The Company has disclosed the information on exposure to the aforementioned risks, the Company's policies and procedures to measure and manage those risks, and the quantitative information below.

The Company's Board of Directors is responsible for developing and monitoring the Company's risk management policies. The Company's risk management policies are established to identify and analyze the risks faced by the Company, to set appropriate risk limits and controls, and to monitor adherence to the controls. Risk management policies and systems are reviewed regularly to reflect changes in market conditions and the Company's operations.

The Company's management monitors and reviews the financial activities in accordance with procedures required by relevant regulations and internal controls. Internal auditors undertake both regular and ad hoc reviews of risk management controls and procedures, the results of which are reported to the Company's Board of Directors.

(i) Credit risk

Credit risk is the risk of financial loss to the Company if a customer or counterparty of a financial instrument fails to meet its contractual obligations, and arises principally from the Company's cash and cash equivalents, notes and receivables from customers (including related parties). The maximum exposure to credit risk is equal to the carrying amount of the Company's financial assets.

The Company maintains cash and cash equivalents with reputable financial institutions. Therefore, the exposure related to potential default by those counter-parties is not considered significant.



## FLYTECH TECHNOLOGY CO., LTD.

### Notes to the Financial Statements

As of December 31, 2020 and 2019, four clients accounted to a total of 49% and 58%, respectively, of the Company's notes and accounts receivable (including related parties). In order to reduce credit risk, the Company has established a credit policy under which each customer is analyzed individually for creditworthiness for the purpose of setting the credit limit. Additionally, the Company continuously evaluates the credit quality of customers and utilizes insurance to minimize the credit risk.

For credit risk exposure and loss allowance of notes and accounts receivables, please refer to note 6(d). Cash, accounts receivable from related parties and other financial assets are considered as low-credit-risk financial assets, and thus, the loss allowance are measured using 12-months ECL, please refer to note 4(f) for descriptions about how the Company determines the credit risk. As of December 31, 2020 and 2019, no loss allowance was provided for these financial assets after management's assessment.

(ii) Liquidity risk

Liquidity risk is the risk that the Company will encounter difficulty in settling its financial liabilities by delivering cash or other financial assets. The Company manages liquidity risk by monitoring regularly the current and estimated mid-term to long-term cash demand, and maintaining adequate cash and cash equivalents, and banking facilities. As of December 31, 2020 and 2019, the Company had unused credit facilities of \$1,174,600 and \$1,179,880, respectively.

The table below summarizes the maturity profile of the Company's financial liabilities based on contractual undiscounted payments.

|  | <u>Contractual<br/>cash flows</u> | <u>Within 1<br/>years</u> | <u>1-2 years</u>    | <u>More than<br/>2 years</u> |
|--|-----------------------------------|---------------------------|---------------------|------------------------------|
| <b>December 31, 2020</b>                     |                                   |                           |                     |                              |
| Non-derivative financial liabilities:        |                                   |                           |                     |                              |
| Accounts payable (including related parties) | 202,306                           | 202,306                   | -                   | -                            |
| Lease liabilities                            | 1,600                             | 1,067                     | 533                 | -                            |
| Other payables                               | 186,296                           | 186,296                   | -                   | -                            |
|  | <u><b>\$ 390,202</b></u>          | <u><b>389,669</b></u>     | <u><b>533</b></u>   | <u><b>-</b></u>              |
| Derivative financial instruments:            |                                   |                           |                     |                              |
| Foreign currency forward contracts:          |                                   |                           |                     |                              |
| Outflow                                      | \$ 391,228                        | 391,228                   | -                   | -                            |
| Inflow                                       | (393,481)                         | (393,481)                 | -                   | -                            |
|  | <u><b>\$ (2,253)</b></u>          | <u><b>(2,253)</b></u>     | <u><b>-</b></u>     | <u><b>-</b></u>              |
| <b>December 31, 2019</b>                     |                                   |                           |                     |                              |
| Non-derivative financial liabilities:        |                                   |                           |                     |                              |
| Accounts payable (including related parties) | \$ 288,875                        | 288,875                   | -                   | -                            |
| Lease liability                              | 2,667                             | 1,067                     | 1,067               | 533                          |
| Other payables                               | 199,789                           | 199,789                   | -                   | -                            |
|  | <u><b>\$ 491,331</b></u>          | <u><b>489,731</b></u>     | <u><b>1,067</b></u> | <u><b>533</b></u>            |
| Derivative financial instruments:            |                                   |                           |                     |                              |
| Foreign currency forward contracts:          |                                   |                           |                     |                              |
| Outflow                                      | \$ 80,673                         | 80,673                    | -                   | -                            |
| Inflow                                       | (80,767)                          | (80,767)                  | -                   | -                            |
|  | <u><b>\$ (94)</b></u>             | <u><b>(94)</b></u>        | <u><b>-</b></u>     | <u><b>-</b></u>              |

## FLYTECH TECHNOLOGY CO., LTD.

### Notes to the Financial Statements

The Company does not expect that the cash flows included in the maturity analysis would occur significantly earlier or at significantly different amounts.

(iii) Market risk

Market risk is the risk that changes in market prices, such as foreign exchange rates and interest rates will affect the Company's income or the value of its financial instruments. The objective of market risk management is to manage and control market risk exposures within acceptable parameters, while optimizing the return.

The Company utilizes derivative financial instruments to manage market risk and the volatility of profit or loss. All such transactions are carried out within the guidelines set by the Company's Board of Directors.

1) Foreign currency risk

The Company's exposure to foreign currency risk arises from cash and cash equivalents, notes and accounts receivable (payables)(including related parties). At the reporting date, the carrying amounts of the Company's significant monetary assets and liabilities denominated in a currency other than the respective functional currencies of Company entities were as follows:

| (Amount in Thousands of Dollars) |                             |                           |            |                                |   |
|----------------------------------|-----------------------------|---------------------------|------------|--------------------------------|---|
| <b>December 31, 2020</b>         |                             |                           |            |                                |   |
|                                  | <b>Foreign<br/>currency</b> | <b>Exchang<br/>e rate</b> | <b>NTD</b> | <b>Change in<br/>magnitude</b> | <b>Pre-tax<br/>effect on<br/>profit or loss</b> |
| <u>Financial assets</u>          |                             |                           |            |                                |   |
| <u>Monetary items</u>            |                             |                           |            |                                |   |
| USD                              | \$ 20,357                   | 28.10                     | 572,032    | 1%                             | 5,720   |
| GBP                              | 2,174                       | 38.90                     | 84,569     | 1%                             | 846   |
| <u>Financial liabilities</u>     |                             |                           |            |                                |   |
| <u>Monetary items</u>            |                             |                           |            |                                |   |
| USD                              | 3,372                       | 28.10                     | 94,753     | 1%                             | 948   |

**FLYTECH TECHNOLOGY CO., LTD.**

**Notes to the Financial Statements**

**December 31, 2019**

|                              | <b>Foreign<br/>currency</b> | <b>Exchang<br/>e rate</b> | <b>NTD</b> | <b>Change in<br/>magnitude</b> | <b>Pre-tax<br/>effect on<br/>profit or<br/>loss</b> |
|------------------------------|-----------------------------|---------------------------|------------|--------------------------------|---|
| <u>Financial assets</u>      |                             |                           |            |                                |   |
| <u>Monetary items</u>        |                             |                           |            |                                |   |
| USD                          | \$ 42,621                   | 29.98                     | 1,277,778  | 1%                             | 12,778  |
| RMB                          | 33,542                      | 4.31                      | 144,566    | 1%                             | 1,446   |
| GBP                          | 2,100                       | 39.36                     | 82,656     | 1%                             | 827   |
| <u>Financial liabilities</u> |                             |                           |            |                                |   |
| <u>Monetary items</u>        |                             |                           |            |                                |   |
| USD                          | 4,681                       | 29.98                     | 140,336    | 1%                             | 1,403   |

For the years ended December 31, 2020 and 2019, the aggregate of realized and unrealized foreign exchange gain (loss) amounted to \$(11,017) and \$(40,360), respectively.

2) Interest rate risk

The Company operates primarily with its own working capital and there is no liabilities bearing floating interest rates at the end of the reporting period.

The changes in interest rate would not cause significant potential financial impact on the Company's financial assets, and therefore the management believes that there is no significant interest risk.

(t) Capital management

In consideration of industry dynamics and future development, as well as external environment factors, the Company maintains an optimal capital structure to enhance long-term shareholder value by managing its capital in a manner to ensure that it has sufficient and necessary financial resources to fund its working capital needs, dividend payments, and other business requirements for continuing operations and to reward shareholders and take into consideration the interests of other stakeholders.

(u) Investing and financing activities not affecting current cash flow

(i) For acquisition of right-of-use assets under operating lease for the year ended December 31, 2020, please refer to note 6(i).

(ii) Reconciliation of liabilities arising from financing activities were as follows:

|                   | <b>January 1,<br/>2020</b> | <b>Cash<br/>flows</b> | <b>Non-cash<br/>changes<br/>Changes in<br/>lease<br/>liabilities</b> | <b>December 31,<br/>2020</b> |
|-------------------|----------------------------|-----------------------|--|------------------------------|
| Lease liabilities | <u>\$ 2,613</u>            | <u>(1,032)</u>        | <u>-</u>   | <u>1,581</u>                 |

**FLYTECH TECHNOLOGY CO., LTD.**

**Notes to the Financial Statements**

|                   | January 1,<br>2019 | Cash<br>flows | Non-cash<br>changes<br>Changes in<br>lease<br>liabilities | December 31,<br>2019 |
|-------------------|--------------------|---------------|---|----------------------|
| Lease liabilities | \$ 926             | (970)         | 2,657   | 2,613                |

**7. Related-party transactions**

- (a) Name and relationship with related parties

The following are the Company's subsidiaries:

| Name of related parties   | Relationship with the<br>Company |
|---|----------------------------------|
| Flytech USA International Co., Ltd. (Flytech USA BVI)             | The Company's subsidiary         |
| Flytech HK International Co., Ltd. (Flytech HK BVI)               | The Company's subsidiary         |
| Flytech CN International Co., Ltd. (Flytech CN BVI)               | The Company's subsidiary         |
| Fei Shiun Investment Co., Ltd. (Fei Shiun Investment)             | The Company's subsidiary         |
| Box Technologies (Holdings) Ltd. (Box Holdings)                   | The Company's subsidiary         |
| Flytech Technology (U.S.A.) Inc. (Flytech USA)                    | The Company's subsidiary         |
| Flytech Technology Hong Kong Ltd. (Flytech HK)                    | The Company's subsidiary         |
| Flytech Technology (Shanghai) Co., Ltd. (Flytech CN)              | The Company's subsidiary         |
| Berry AI Inc. (Berry AI)  | The Company's subsidiary         |
| iRugby System Co., Ltd. (iRugby System)                           | The Company's subsidiary         |
| Poindus Systems Corporation (Poindus Systems)                     | The Company's subsidiary         |
| Poindus Investment Co., Ltd. (Poindus Investment)                 | The Company's subsidiary         |
| Poindus Systems UK Limited (Poindus UK)                           | The Company's subsidiary         |
| Adasys GmbH Elektronische Komponenteas (Adasys)                   | The Company's subsidiary         |
| Qijie Electronics (Shenzhen) Co., Ltd                             | The Company's subsidiary         |
| Poindus Systems GmbH GroBhandel mit EDV. Oberursel (Poindus GmbH) | The Company's subsidiary         |
| Box Technologies Limited (Box UK)                                 | The Company's subsidiary         |
| BTechnologies AB (Box Nordic)                                     | The Company's subsidiary         |

- (b) Significant related-party transactions:

- (i) Revenue

|                 | 2020       | 2019    |
|-----------------|------------|---------|
| Subsidiaries:   |            |         |
| Box UK          | \$ 202,313 | 250,092 |
| Poindus Systems | 304,931    | 162,906 |
| Others          | 106,005    | 143,346 |
|                 | \$ 613,249 | 556,344 |

**FLYTECH TECHNOLOGY CO., LTD.**

**Notes to the Financial Statements**

The selling price and payment terms of sales offered to related parties depend on the economic environment and market competition, the trade terms of sales to related parties are EOM 60~180 days, and there are occasional late collections from related parties in consideration of their working capital management. In addition, the trade terms offered to third parties are OA 30~75 days. Receivables from related parties were not secured with collateral and did not require provisions for expected credit loss.

(ii) Purchases

|              | <b>2020</b>      | <b>2019</b>   |
|--------------|------------------|---------------|
| Subsidiaries | <b>\$ 15,823</b> | <b>19,168</b> |

The purchases price for the abovementioned transactions were not comparable to the purchases price for third-party vendors as the specifications of products were different. The payment terms of 60 days shows no significant difference between related parties and third-party vendors.

(iii) Operating expenses

Operating expenses related to the commissions and product development by related parties were as below:

| <b>Account</b>     | <b>Related-party categories</b> | <b>2020</b>      | <b>2019</b>   |
|--------------------|---------------------------------|------------------|---------------|
| Operating expenses | Subsidiaries                    | <b>\$ 23,157</b> | <b>26,677</b> |

(iv) Receivables from related parties

| <b>Account</b>                      | <b>Related party categories</b> | <b>December 31, 2020</b> | <b>December 31, 2019</b> |
|-------------------------------------|---------------------------------|--------------------------|--------------------------|
| Accounts receivable-related parties | Subsidiaries—Box UK             | \$ 80,097                | 78,349                   |
| Accounts receivable-related parties | Other subsidiaries              | 62,856                   | 54,213                   |
|                                     |                                 | <b>\$ 142,953</b>        | <b>132,562</b>           |

(v) Payables to related parties

| <b>Account</b>                   | <b>Related party categories</b> | <b>December 31, 2020</b> | <b>December 31, 2019</b> |
|----------------------------------|---------------------------------|--------------------------|--------------------------|
| Accounts payable related parties | Subsidiaries                    | <b>\$ 3,839</b>          | <b>4,138</b>             |

**FLYTECH TECHNOLOGY CO., LTD.**

**Notes to the Financial Statements**

(c) Compensation of key management personnel

|                              | <b>2020</b>      | <b>2019</b>   |
|------------------------------|------------------|---------------|
| Short-term employee benefits | \$ 35,540        | 41,820        |
| Post-employment benefits     | 1,585            | 1,158         |
|                              | <b>\$ 37,125</b> | <b>42,978</b> |

**8. Pledged assets**

The carrying amounts of assets pledged as collateral are detailed below:

|  |                                     | <b>December 31,<br/>2020</b> | <b>December 31,<br/>2019</b> |
|--|-------------------------------------|------------------------------|------------------------------|
| <b>Pledged assets</b>                              | <b>Pledged to secure</b>            |                              |                              |
| Time deposits (classified as other current assets) | Guarantee deposit for custom duties | <b>\$ 226</b>                | <b>224</b>                   |

**9. Significant commitments and contingencies: None**

**10. Significant losses due to major disasters: None**

**11. Significant subsequent events :None**

**12. Others**

Employee benefits, depreciation, and amortization expenses, categorized by function, were as follows:

| By function               | 2020            |                    |         | 2019            |                    |         |
|---------------------------|-----------------|--------------------|---------|-----------------|--------------------|---------|
|                           | Cost of revenue | Operating expenses | Total   | Cost of revenue | Operating expenses | Total   |
| <b>By item</b>            |                 |                    |         |                 |                    |         |
| Employee benefits:        |                 |                    |         |                 |                    |         |
| Salaries                  | 116,768         | 225,104            | 341,872 | 136,982         | 239,489            | 376,471 |
| Insurance                 | 10,632          | 16,560             | 27,192  | 11,849          | 16,380             | 28,229  |
| Pension                   | 4,218           | 9,315              | 13,533  | 4,510           | 9,067              | 13,577  |
| Remuneration to directors | -               | 4,480              | 4,480   | -               | 5,040              | 5,040   |
| Others                    | 4,471           | 5,412              | 9,883   | 4,829           | 5,119              | 9,948   |
| Depreciation              | 68,106          | 10,938             | 79,044  | 69,275          | 11,993             | 81,268  |
| Amortization              | -               | 2,414              | 2,414   | 62              | 3,127              | 3,189   |

**FLYTECH TECHNOLOGY CO., LTD.**

**Notes to the Financial Statements**

|  | <b>2020</b>    | <b>2019</b>  |
|--|----------------|--------------|
| The number of employees                | <b>411</b>     | <b>428</b>   |
| The number of non-employee directors   | <b>5</b>       | <b>5</b>     |
| Average employee benefits              | <b>\$ 967</b>  | <b>1,012</b> |
| Average employee salaries              | <b>\$ 842</b>  | <b>890</b>   |
| Average employee salaries decreased by | <b>(5.39)%</b> |              |
| Supervisors' remuneration (note)       | <b>\$ -</b>    | <b>-</b>     |

(Note) As the Company had established an Audit Committee, there was no remuneration policy for supervisor.

The Company's salary and remuneration policy, including directors, supervisors, managers and employees, is as follows:

- (a) The amounts of remuneration for directors and independent directors depend on the factors including responsibilities of directors, risks bore by the directors, and their time committed to the Company. Moreover, the criteria mentioned below will also be considered to prepare a payment scheme which will be approved by the Remuneration Committee and the Board of Directors:
  - (i) Their commitment and contribution to the board meeting, including their attendance, quantity and quality of their proposals, as well as their contribution to the ordinary operation of the Company, such as discussion with external and internal auditors as well as company executives.
  - (ii) The pay levels within the domestic and overseas market.
  - (iii) Individual performance and overall performance of the board.
  - (iv) Overall operating performance of the Company.
  - (v) Pursuant to the Company's articles of incorporation, the Company shall distribute 3% to 15% of its profits in the current period as remuneration to its employees and no more than 3% to its directors.
  
- (b) The remuneration policy for managers and employees is decided by the human resource department which takes into consideration their duties, personal KPI and contribution to the Company's overall operating performance achievement rate. Furthermore, the pay levels in the domestic and overseas market will also be taken into consideration. Human resource department would also set up a remuneration policy based on the related internal guidances. A proposal will be submitted by human resource department to the remuneration committee and Board of Directors for approval. The remuneration policy is regularly reviewed to ensure its reasonableness.

**FLYTECH TECHNOLOGY CO., LTD.**

**Notes to Financial Statements**

**13. Additional disclosures**

(a) Information on significant transactions:

In accordance with the requirements of the Regulations Governing the Preparation of Financial Reports by Securities Issuers, the Company discloses the following information on significant transactions for the year ended December 31, 2019:

(i) Financing provided to other parties:

(Amounts in Thousands of New Taiwan Dollars/Euro)

| No.<br>(Note 1) | Financing<br>Company | Counter-p<br>arty | Financial<br>Statement<br>Account | Related<br>Parties | Maximum<br>Balance for<br>the Period | Ending<br>Balance   | Actual<br>Drawdown<br>Amounts | Interest<br>Rate | Nature of<br>Financing<br>(Note 2) | Transaction<br>Amounts | Reasons<br>for<br>Short-ter<br>m<br>Financing | Allowance<br>for<br>Doubtful<br>Accounts | Collateral |       | Financing<br>Limits for<br>Each<br>Borrowin<br>g<br>Company<br>(Note 3) | Financing<br>Company's<br>Total<br>Financing<br>Amount<br>Limits<br>(Note 3) |
|-----------------|----------------------|-------------------|-----------------------------------|--------------------|--------------------------------------|---------------------|-------------------------------|------------------|------------------------------------|------------------------|---|--|------------|-------|---|--|
|                 |                      |                   |                                   |                    |                                      |                     |                               |                  |                                    |                        |   |  | Item       | Value |   |  |
| 1               | Poindus<br>Systems   | Adasys            | Long term<br>other<br>receivables | Yes                | 22,802<br>(EUR 650)                  | 22,763<br>(EUR 650) | 22,763<br>(EUR 650)           | 4%               | 1                                  | 108,779                |   | -  |            | -     | 52,949  | 211,794  |
| 2               | Poindus<br>Systems   | Poindus<br>UK     | Long term<br>other<br>recievables | Yes                | 31,416<br>(GBP 800)                  | 31,120<br>(GBP 800) | 31,120<br>(GBP 800)           | 1%               | 1                                  | 17,031                 |   | -  |            | -     | 17,031  | 211,794  |

Note 1. Parties to intercompany transactions are identified and numbered as follows:

1. "0" represents the Company
2. Subsidiaries are numbered from "1".

Note 2. Nature of financing

1. Business transaction purpose
2. Short-term financing

Note 3. The individual financing amounts shall not exceed the lower amounts of transaction amounts of the most recent year and 10% of the most recent audited or reviewed net worth of Poindus Systems. The aggregate financing amount shall not exceed 40% of the most recent audited or reviewed net worth of Poindus Systems.

(ii) Guarantees and endorsements provided to other parties:

(In Thousands of New Taiwan Dollars)

| No. | Endorsement/<br>Guarantee<br>Provider | Guarantee Party                 |                                     | Limit on<br>Endorsement/<br>Guarantee<br>Amount<br>Provided to<br>Each<br>Guarantee<br>Party | Maximum<br>Balance for the<br>Period | Ending<br>Balance | Amount<br>Actually<br>Drawn | Amount of<br>Endorsement/<br>Guarantee<br>Collateralized<br>by Properties | Ratio of<br>Accumulated<br>Endorsement/<br>Guarantee to<br>Net Equity per<br>Latest Financial<br>Statements | Maximum<br>Endorsement/<br>Guarantee<br>Amount<br>Allowable<br>(Note 3) | Guarantee<br>Provided by<br>Parent<br>Company | Guarantee<br>Provided by<br>A Subsidiary | Guarantee<br>Provided to<br>Subsidiaries in<br>Mainland<br>China |
|-----|---------------------------------------|---------------------------------|-------------------------------------|--|--------------------------------------|-------------------|-----------------------------|---|---|---|---|--|--|
|     |                                       | Name                            | Name of<br>Relationship<br>(Note 2) |  |                                      |                   |                             |   |   |   |   |  |  |
| 0   | The Company                           | Box<br>Technologi<br>es limited | 2                                   | 866,834  | 80,000                               | 80,000            | -                           | -   | 1.85%   | 2,167,085   | Y   | N  | N  |

Note 1: The numbers filled in for the endorsements/guarantees provided by the Company or subsidiaries are as follows:

1. The Company is '0'
2. The subsidiaries are numbered in order starting from "1"

Note 2: Relationship between the endorser/guarantor and the party being endorsed/guaranteed is classified as "2", the endorser/guarantor which the parent company owns directly more than 50% of its voting shares.

Note 3: The Company provide guaranteed to subsidiary that the company owns directly 100% voting shares, the limit on endorsement or guarantee provided by the Company to a single party should not exceed 20% of its net worth. The total amount of endorsement or guarantee provided by the company should not exceed 50% of its net worth.

(iii) Marketable securities held at the reporting date (excluding investments in subsidiaries, associates, and jointly controlled entities):

(Amounts in Thousands of New Taiwan Dollars and shares)

| Investing<br>Company | Marketable<br>Securities<br>Type and Name           | Relationship<br>with the<br>Securities Issuer | Financial<br>Statement<br>Account  | Ending Balance      |                   |                            |            | Note |
|----------------------|---|---|--|---------------------|-------------------|----------------------------|------------|------|
|                      |   |   |  | Number of<br>Shares | Carrying<br>Value | Percentage of<br>Ownership | Fair value |      |
| The Company          | Convertible bond;<br>Nextronics<br>engineering core | -   | Financial assets at<br>fair value through<br>profit or loss —<br>current | 0.1                 | 9,516             | -                          | 9,516      | -    |
| Flytech CN BVI       | Convertible bond;<br>Astra cloud holdings           | -   | Financial assets at<br>fair value through<br>profit or loss —<br>current | -                   | -                 | -                          | -          | -    |

(iv) Marketable securities for which the accumulated purchase or sale amounts for the year exceed \$300 million or 20% of the paid-in capital: None

(v) Acquisition of real estate which exceeds \$300 million or 20% of the paid-in capital: None



**FLYTECH TECHNOLOGY CO., LTD.**

**Notes to Financial Statements**

(vi) Disposal of real estate which exceeds \$300 million or 20% of the paid-in capital: None

(vii) Total purchases from and sales to related parties which exceed \$100 million or 20% of the paid-in capital:

(Amounts in Thousands of New Taiwan Dollars)

| Company Name | Related Party   | Relationship | Transaction Details |                 |                               |               | Transactions with Terms Different from Others |               | Notes/Accounts Receivable (Payable) |  | Note |
|--------------|-----------------|--------------|---------------------|-----------------|-------------------------------|---------------|---|---------------|-------------------------------------|--|------|
|              |                 |              | Purchases/ (Sales)  | Amount (Note 3) | % of Total Purchases/ (Sales) | Payment Terms | Unit Price                                    | Payment Terms | Ending Balance                      | % of Total Notes/Accounts Receivable (Payable) |      |
| The Company  | Poindus Systems | Subsidiary   | (Sales)             | 304,931         | 6.88%                         | EM 60         | (Note 1)                                      | (Note 2)      | 45,379                              | 7.81%  |      |
| The Company  | Box UK          | Subsidiary   | (Sales)             | 202,313         | 4.56%                         | EM 180        | (Note 1)                                      | (Note 2)      | 80,097                              | 13.78%   |      |

Note 1: The selling prices with related parties are influenced by the economic environment and market competitiveness in each regions.

Note 2: The trade terms of sales with related parties are EOM 60~180 days, and the trade terms with third parties are OA 30~75 days.

Note 3: The intercompany transactions are disclosed only for the amounts of sales; the corresponding purchases are not disclosed.

(viii) Receivables from related parties which exceed \$100 million or 20% of the paid-in capital: None

(ix) Transactions in derivative instruments: Refer to note 6(b)

(b) Information on investees:

The following is the information on investees for the years ended December 31, 2020 (excluding information on investees in Mainland China):

(Amounts in Thousands of shares/ foreign currency and New Taiwan Dollars)

| Investor             | Investee             | Location               | Main Businesses and Products   | Original Investment Amount |                       | Balance as of December 31, 2020 |                         |                        | Net Income (Loss) of the Investee | Investment Income (Loss) | Note |
|----------------------|----------------------|------------------------|--|----------------------------|-----------------------|---------------------------------|-------------------------|------------------------|-----------------------------------|--------------------------|------|
|                      |                      |                        |  | December 31, 2020          | December 31, 2019     | Shares                          | Percentage of Ownership | Carrying value         |                                   |                          |      |
| The Company          | Flytech USA BVI      | British Virgin Islands | Investment and holding activity  | 38,652                     | 38,652                | 100                             | 100.00%                 | 17,227                 | (224)                             | (224)                    |      |
| The Company          | Flytech HK BVI       | British Virgin Islands | Investment and holding activity  | 10,392                     | 10,392                | 50                              | 100.00%                 | 133,517                | 5,249                             | 5,249                    |      |
| The Company          | Flytech CN BVI       | British Virgin Islands | Investment and holding activity  | 90,601                     | 90,601                | 200                             | 100.00%                 | 126,805                | 4,047                             | 4,047                    |      |
| The Company          | Fei Shiun Investment | Taiwan                 | Investment and holding activity  | 428,000                    | 428,000               | 19,000                          | 100.00%                 | 374,689                | (3,535)                           | (3,535)                  |      |
| The Company          | Box Holdings         | United Kingdom         | Investment and holding activity  | 511,307                    | 511,307               | 4                               | 100.00%                 | 434,484                | 9,406                             | (20,579)                 |      |
| Flytech USA BVI      | Flytech USA          | USA                    | Sale of computers and peripherals  | 36,358<br>(USD1,072)       | 36,358<br>(USD1,072)  | 700                             | 100.00%                 | 16,262<br>(USD579)     | (224)<br>(USD8)                   | -                        |      |
| Flytech HK BVI       | Flytech HK           | Hong Kong              | Sale of computers and peripherals  | 10,433<br>(USD298)         | 10,433<br>(USD298)    | 1,000                           | 100.00%                 | 135,135<br>(USD4,809)  | 5,249<br>(USD178)                 | -                        |      |
| Flytech HK           | iSAPPOS              | Hong Kong              | Sale of computers and peripherals  | 31,690<br>(HKD7,500)       | 31,690<br>(HKD7,500)  | (Note 1)                        | 100.00%                 | 2,486<br>(HKD677)      | (36)<br>(HKD9)                    | -                        |      |
| Fei Shiun Investment | Berry AI             | Taiwan                 | Operating software design and data processing services, and integrating software and hardware services | 42,000                     | 42,000                | 4,200                           | 70.00%                  | 15,030                 | (27,245)                          | -                        |      |
| Fei Shiun Investment | iRUGGY System        | Taiwan                 | Sale of computers and peripherals  | 60,000                     | 48,000                | 6,000                           | 100.00%                 | 25,976                 | 167                               | -                        |      |
| Fei Shiun Investment | Poindus Systems      | Taiwan                 | Sale of computers and peripherals  | 308,070                    | 308,070               | 10,354                          | 49.31%                  | 270,178                | 37,519                            | -                        |      |
| Poindus Systems      | Poindus Investment   | Taiwan                 | Investment and holding activities  | 4,100                      | 4,100                 | (Note 1)                        | 100.00%                 | 752                    | (95)                              | -                        |      |
| Poindus Systems      | Adasys               | Germany                | Sale of computers and peripherals  | 57,712<br>(EUR 1,730)      | 57,712<br>(EUR 1,730) | 0.002                           | 100.00%                 | 13,003                 | 2,537                             | -                        |      |
| Poindus Systems      | Poindus UK           | United Kingdom         | Sale of computers and peripherals  | 14,297<br>(GBP 300)        | 14,297<br>(GBP 300)   | 300                             | 100.00%                 | (10,450)               | (3,735)                           | -                        |      |
| Poindus Investment   | Poindus GmbH         | Germany                | Sale of computers and peripherals  | 1,721<br>(EUR 40)          | 1,721<br>(EUR 40)     | (Note 1)                        | 100.00%                 | 303                    | (95)                              | -                        |      |
| Box Holdings         | Box UK               | United Kingdom         | Sale of computers and peripherals  | 472<br>(GBP 10)            | 472<br>(GBP 10)       | 10                              | 100.00%                 | 243,133<br>(GBP 6,250) | 9,795<br>(GBP 257)                | -                        |      |
| Box Holdings         | Box Nordic           | Sweden                 | Sale of computers and peripherals  | 2,330<br>(GBP 49)          | 2,330<br>(GBP 49)     | 5                               | 100.00%                 | 7,928<br>(GBP 204)     | 729<br>(GBP 19)                   | -                        |      |

Note 1: There were no shares as the company is a limited liability company.

**FLYTECH TECHNOLOGY CO., LTD.**

**Notes to Financial Statements**

(c) Information on investment in mainland China:

(i) Information on investment in Mainland China

(Amounts in Thousands of New Taiwan Dollars and US Dollars)

| Investee   | Main Businesses and Products      | Total Amount of Paid-in Capital | Method of Investment | Accumulated Outflow of Investment from Taiwan as of January 1, 2020 | Investment Flows      |        | Accumulated Outflow of Investment from Taiwan as of December 31, 2020 | Net Income (Loss) of Investee | % of Ownership of Direct and Indirect Investment | Investment Income (Loss) | Carrying Value as of December 31, 2020 | Accumulated Inward Remittance of Earnings as of December 31, 2020 |
|------------|-----------------------------------|---------------------------------|----------------------|---|-----------------------|--------|---|-------------------------------|--|--------------------------|--|---|
|            |                                   |                                 |                      |   | Outflow               | Inflow |   |                               |  |                          |  |   |
| Flytech CN | Sale of computers and peripherals | 69,089<br>(USD 2,000)           | (Note 1)             | 69,089<br>(USD 2,000)   | -                     | -      | 69,089<br>(USD 2,000)   | 7,800<br>(USD 262)            | 100.00%  | 7,800<br>(USD 262)       | 116,225<br>(USD 3,944)                 | -   |
| Qijie      | Sale of computers and peripherals | 30,850<br>(USD 1,000)           | (Note 2)             | 6,258<br>(USD 200)  | 29,630<br>(USD 1,000) | -      | 35,888<br>(USD 1,200)   | (2,772)                       | 49.31%   | (2,275)                  | 25,918                                 | -   |

Note 1: Indirect investment in Mainland China through a holding company, Flytech CN BVI, established in a third country

Note 2:(1)Flytech CN BVI reinvested the amount of USD392 thousand it incurred from the liquidation of Flytech BJ, together with its own funds, and acquired 40% ownership of Qijie.

(2)In 2019, the Company acquired an additional 20% share ownership of Qijie through Flytech CN BVI.

(3)The 60% and 40% ownership of Flytech CN BVI and the third parties amounting to USD600 and USD400, respectively, in Qijie were acquired by Poindus Systems in 2020, resulting in Poindus System to fully own Qijie.

(ii) Limits on investment in Mainland China

(Amounts in Thousands of New Taiwan Dollars and US Dollars)

| Accumulated investment in Mainland China as of December 31, 2020 | Investment amount authorized by Ministry of Economic Affairs Investment Commission | Upper limit on investment |
|--|--|---------------------------|
| 120,397<br>(USD 3,700)   | 121,617<br>(USD 4,100)   | 2,600,502                 |

(iii) Significant transactions with the investee in Mainland China: None

(d) Major shareholders:

| Shareholder's Name | Shareholding | Shares     | Percentage |
|--------------------|--------------|------------|------------|
| Lam Tai Seng       |              | 16,423,263 | 11.47%     |
| Wang Wei Wei       |              | 11,040,443 | 7.71%      |

**14. Segment information**

Please refer to the consolidated financial statements for the years ended December 31, 2020 and 2019 for disclosure of segment information.

**Flytech Technology Co., Ltd.**  
**Statement of Cash and Cash Equivalents**  
**December 31, 2020**  
**(Expressed in Thousands of New Taiwan Dollars)**

| <u>Item</u>                                | <u>Description</u>                         | <u>Amount</u>              |
|--|--|----------------------------|
| Cash on hand and cash in foreign currency  |  | \$ 738                     |
| Demand deposits                            |  | 1,736,646                  |
| Checking accounts                          |  | 8                          |
| Foreign currency deposits (Note 1)         | USD : 2,992 thousand<br>CNY : 389 thousand | 90,256                     |
| Time deposits (mature within three months) |  | <u>10,000</u>              |
|  |  | <u><b>\$ 1,837,648</b></u> |

Note 1: Foreign currency deposits were translated at the spot exchange rate on December 31, 2020 as follows:

| <u>Currency</u> | <u>Exchange rate</u> |
|-----------------|----------------------|
| USD             | 28.10                |
| CNY             | 4.377                |

**Flytech Technology Co., Ltd.**  
**Statement of Notes and Accounts Receivable**  
**December 31, 2020**  
**(Expressed in Thousands of New Taiwan Dollars)**

| <u>Name of Customers</u> | <u>Description</u> | <u>Amount</u>            | <u>Note</u> |
|--------------------------|--------------------|--------------------------|-------------|
| Customer A               |                    | \$ 101,677               |             |
| Customer B               |                    | 55,000                   |             |
| Customer C               |                    | 44,851                   |             |
| Customer D               |                    | 22,923                   |             |
| Customer E               |                    | 22,293                   |             |
| Other (less than 5%)     |                    | 199,817                  |             |
| Less : Loss allowance    |                    | <u>(8,299)</u>           |             |
|                          |                    | <b><u>\$ 438,262</u></b> |             |

**Statement of Accounts Receivable From Related Parties**

| <u>Name of related parties</u> | <u>Amount</u>            |
|--------------------------------|--------------------------|
| Poindus Systems Corp.          | \$ 45,379                |
| Box Technologies Limited       | 80,097                   |
| Flytech CN                     | 9,966                    |
| Other (less than 5%)           | <u>7,511</u>             |
|                                | <b><u>\$ 142,953</u></b> |

**Flytech Technology Co., Ltd.**

**Statement of Inventories**

**December 31, 2020**

**(Expressed in Thousands of New Taiwan Dollars)**

| <b>Item</b>     | <b>Amount</b>              |                                     | <b>Note</b> |
|-----------------|----------------------------|-------------------------------------|-------------|
|                 | <b>Carrying<br/>amount</b> | <b>Net<br/>realizable<br/>value</b> |             |
| Raw materials   | \$ 226,971                 | 226,971                             |             |
| Work in porcess | 137,791                    | 184,728                             |             |
| Finished goods  | 21,798                     | 31,139                              |             |
|                 | <b><u>\$ 386,560</u></b>   | <b><u>442,838</u></b>               |             |

**Statement of Prepayments and Other Current Assets**

| <b>Item</b>               | <b>Description</b> | <b>Amount</b>          | <b>Note</b> |
|---------------------------|--------------------|------------------------|-------------|
| VAT refund                |                    | \$ 6,696               |             |
| Prepayment for purchase   |                    | 962                    |             |
| Prepaid insurance expense |                    | 883                    |             |
| Other (less than 5%)      |                    | 1,205                  |             |
|                           |                    | <b><u>\$ 9,746</u></b> |             |

Flytech Technology Co., Ltd.

Statement of Changes in Investments Accounted for Using Equity Method

For the year ended December 31, 2020

(Expressed in Thousands of New Taiwan Dollars)

| Name of investees   | Balance at January 1, 2020 |                     | Addition |              | Decrease |                | Investment income method | Foreign currency difference | Changes in remittance benefit plan | Realized (unrealized) gross profit | Balance at December 31, 2020 |         |                  | Total equity | Collateral or pledge |
|---------------------|----------------------------|---------------------|----------|--------------|----------|----------------|--------------------------|-----------------------------|------------------------------------|------------------------------------|------------------------------|---------|------------------|--------------|----------------------|
|                     | Shares                     | Amount              | Shares   | Amount       | Shares   | Amount         |                          |                             |                                    |                                    | Shares                       | %       | Amount           |              |                      |
| Flytech USA BVI     | 100                        | \$ 18,601           | -        | -            | -        | -              | (224)                    | (1,156)                     | -                                  | 6                                  | 100                          | 100.00% | 17,227           | 17,233       | No                   |
| Flytech HK BVI      | 50                         | 134,828             | -        | -            | -        | -              | 5,249                    | (6,422)                     | -                                  | (138)                              | 50                           | 100.00% | 133,517          | 135,155      | No                   |
| Flytech CN BVI      | 200                        | 116,678             | -        | 2,148        | -        | -              | 4,047                    | 412                         | -                                  | 3,520                              | 200                          | 100.00% | 126,805          | 127,809      | No                   |
| Fei-Syun Investment | 19,000                     | 384,985             | -        | -            | -        | (8,661)        | (3,535)                  | 835                         | (977)                              | 2,042                              | 19,000                       | 100.00% | 374,689          | 383,761      | No                   |
| Box Holdings        | 4                          | 456,570             | -        | -            | -        | -              | (20,579)                 | (1,422)                     | -                                  | (85)                               | 4                            | 100.00% | 434,484          | 210,865      | No                   |
|                     |                            | <u>\$ 1,111,662</u> |          | <u>2,148</u> |          | <u>(8,661)</u> | <u>(15,042)</u>          | <u>(7,753)</u>              | <u>(977)</u>                       | <u>5,345</u>                       |                              |         | <u>1,086,722</u> |              |                      |

**Flytech Technology Co., Ltd.**  
**Statement of Change in of Intangible Assets**  
**For the year ended December 31, 2020**  
**(Expressed in Thousands of New Taiwan Dollars)**

| <b>Item</b>       | <b>Begining<br/>balance</b> | <b>Increase<br/>during 2020</b> | <b>Decrease<br/>during 2020</b> | <b>Ending<br/>balance</b> | <b>Note</b>                           |
|-------------------|-----------------------------|---------------------------------|---------------------------------|---------------------------|---------------------------------------|
| Cost :            |                             |                                 |                                 |                           |                                       |
| Computer software | \$ 37,335                   | 253                             | -                               | 37,588                    |                                       |
| Amortization :    |                             |                                 |                                 |                           |                                       |
| Computer software | <u>(33,901)</u>             | <u>(2,414)</u>                  | <u>-</u>                        | <u>(36,315)</u>           | Amortizing by<br>straight-line method |
|                   | <b><u>\$ 3,434</u></b>      | <b><u>(2,161)</u></b>           | <b><u>-</u></b>                 | <b><u>1,273</u></b>       |                                       |

**Statement of Notes and Accounts Payable**

**December 31, 2020**

| <b>Name of cusomers</b> | <b>Description</b> | <b>Amount</b>            | <b>Note</b> |
|-------------------------|--------------------|--------------------------|-------------|
| Vendor A                |                    | \$ 28,800                |             |
| Vendor B                |                    | 13,710                   |             |
| Other (less than 5%)    |                    | <u>155,957</u>           |             |
|                         |                    | <b><u>\$ 198,467</u></b> |             |

**Flytech Technology Co., Ltd.**

**Statement of Other Payables**

**December 31, 2020**

**(Expressed in Thousands of New Taiwan Dollars)**

| <b>Item</b>                       | <b>Description</b> | <b>Amount</b>     | <b>Note</b> |
|-----------------------------------|--------------------|-------------------|-------------|
| Accrued remuneration to employees |                    | \$ 74,631         |             |
| Accrued Bonus                     |                    | 45,704            |             |
| Salaries and wages payable        |                    | 20,754            |             |
| Other (less than 5%)              |                    | 45,207            |             |
|                                   |                    | <u>\$ 186,296</u> |             |

**Statement of Other Current Liabilities**

| <b>Item</b>                          | <b>Description</b> | <b>Amount</b>    | <b>Note</b> |
|--------------------------------------|--------------------|------------------|-------------|
| Contract liabilities                 |                    | \$ 17,771        |             |
| Deferred revenue for extend warranty |                    | 2,748            |             |
| Receipts under custody               |                    | 768              |             |
|                                      |                    | <u>\$ 21,287</u> |             |



**Flytech Technology Co., Ltd.**

**Statement of Lease Liabilities**

**December 31, 2020**

**(Expressed in Thousands of New Taiwan Dollars)**

| <b>Item</b>     | <b>Lease period</b> | <b>Discount<br/>Rate</b> | <b>Ending<br/>balance</b> |
|-----------------|---------------------|--------------------------|---------------------------|
| Other equipment | 2019/7/15~2022/7/14 | 1.70%                    | <u><u>\$ 1,581</u></u>    |
| Current         |                     |                          | <u><u>\$ 1,049</u></u>    |
| Non-current     |                     |                          | <u><u>\$ 532</u></u>      |

**Statement of Revenue**

**For the year ended December 31, 2020**

| <b>Item</b>                          | <b>Amount</b>              | <b>Note</b> |
|--------------------------------------|----------------------------|-------------|
| Industries computers                 | \$ 2,901,451               |             |
| Other peripheral products            | 353,478                    |             |
| Service, repairs and other<br>income | <u>23,804</u>              |             |
|                                      | <u><u>\$ 3,278,733</u></u> |             |

**Flytech Technology Co., Ltd.**  
**Statement of Cost of Revenue**  
**For the year ended December 31, 2020**  
**(Expressed in Thousands of New Taiwan Dollars)**

| <u>Item</u>                              | <u>Amount</u>              |
|--|----------------------------|
| Raw materials                            |                            |
| Raw materials, beginning of year         | \$ 231,711                 |
| Add : Net purchase                       | 1,806,649                  |
| Transferred from outsourcing processing  | 11,634                     |
| Less : Ending balance                    | 259,080                    |
| Transferred to expenses and others       | 14,604                     |
| Cost of sales on raw materials           | <u>45,808</u>              |
| Raw materials used                       | 1,730,502                  |
| Direct labor                             | 54,130                     |
| Manufacturing overhead                   | <u>171,326</u>             |
| Manufacturing cost                       | 1,955,958                  |
| Add : Work in process, beginning of year | 124,394                    |
| Purchases                                | 111,555                    |
| Less : Work in process, end of year      | 137,862                    |
| Transferred to expenses and others       | 11,368                     |
| Cost of sales on work in process         | <u>147,136</u>             |
| Cost of goods manufactured               | 1,895,541                  |
| Add : Finished goods, beginning of year  | 49,175                     |
| Purchases                                | 1,726                      |
| Less : Finished goods, end of year       | 22,117                     |
| Transferred to expenses and others       | <u>174</u>                 |
| Cost of sales                            | <u>1,924,151</u>           |
| Cost of sales on raw materials           | 45,808                     |
| Cost of sales on work in process         | 147,136                    |
| Losses on scrap of inventories           | 18,062                     |
| Others                                   | <u>12,001</u>              |
| Cost of Revenue                          | <u><u>\$ 2,147,158</u></u> |

**Flytech Technology Co., Ltd.**

**Statement of Operating Expenses**

**For the year ended December 31, 2020**

**(Expressed in Thousands of New Taiwan Dollars)**

| <u>Item</u>                  | <u>Selling<br/>expenses</u> | <u>Administrative<br/>expenses</u> | <u>Research and<br/>development<br/>expenses</u> |
|------------------------------|-----------------------------|------------------------------------|--|
| Salaries and wages           | \$ 58,686                   | 63,585                             | 102,833  |
| Commission expense           | 32,914                      | -                                  | -  |
| Advertising expense          | 4,775                       | 310                                | 3  |
| Insurance expense            | 6,860                       | 4,824                              | 7,871  |
| Depreciation expense         | 1,076                       | 6,866                              | 2,996  |
| Research expense             | -                           | -                                  | 27,442   |
| Professional service expense | 7,360                       | 6,560                              | 1,018  |
| Other expense (less than 5%) | 24,378                      | 34,122                             | 16,573   |
| <b>Total</b>                 | <b><u>\$ 136,049</u></b>    | <b><u>116,267</u></b>              | <b><u>158,736</u></b>                            |

Please refer to note 6(g) for statement of movement of property, plant and equipment.

Please refer to note 6(h) for statement of movement of right-of-use assets.

Please refer to note 6(l) for deferred tax assets and liabilities.

Please refer to note 6(j) for statement of provisions.

Please refer to note 6(k) for statement of net defined benefit liabilities.

Please refer to note 6(q) for statement of other income, other gain or loss and finance costs.

Flytech Technology Co., Ltd.  
Statement of Internal Control System

Date: Mar 18<sup>th</sup> 2021

Based on the findings of a self-assessment, Flytech Technology Co., Ltd. (Flytech) states the following with regard to its internal control system during the year 2020:

1. Flytech's Board of Directors and Management are responsible for establishing, implementing, and maintaining an adequate internal control system, and Flytech has established such a system. Our internal control system is designed to provide reasonable assurance over the effectiveness and efficiency of operations (including profitability, performance, and safeguarding of assets), reliability, timeliness, transparency of reporting, and compliance with applicable laws and regulations.
2. An internal control system has its inherent limitations. No matter how perfectly designed, an effective internal control system can only provide reasonable assurance of accomplishment the objectives mentioned above. Furthermore, the effectiveness of an internal control system may be subject to changes due to circumstances beyond control. Nevertheless, the internal control system of Flytech contains self-monitoring mechanisms, and Flytech takes immediate remedial actions in response to any identified deficiencies.
3. Flytech evaluates the design and operating effectiveness of its internal control system based on the criteria provided in the "Regulations Governing the Establishment of Internal Control Systems by Public Companies" (herein below, the "Regulations"). The criteria adopted by the Regulations identify five components of managerial internal control: (1) control environment, (2) risk assessment, (3) control activities, (4) information and communication, and (5) monitoring activities. Each component further contains several items. Please refer to the Regulations for details.
4. Flytech has evaluated the design and operating effectiveness of its internal control system according to the aforesaid criteria.
5. Based on the findings of the evaluation mentioned in the preceding paragraph, Flytech believes that, on December 31, 2020, it has maintained, in all material respects, and effective internal control system (that includes the supervision and management of subsidiaries), to provide reasonable assurance over operational effectiveness and efficiency, reliability, timeliness, transparency of reporting, and compliance with applicable laws and regulations.
6. This Statement will be an integral part of Flytech's Annual Report and Prospectus and will be made public. Any falsehood, concealment, or other illegality in the content made public will entail legal liability under Articles 20, 32, 171, and 174 of the Securities and Exchange Act.
7. This Statement has been passed by the Board of Directors in their meeting on March 18th, 2021, with none of the seven attending directors expressing dissenting opinions, and remainders all affirming the content of this Statement.

Flytech Technology Co.,Ltd.

Chairman  
Lam Tai Seng

President  
Chuo Chun Hung

飛捷科技股份有限公司



負責人：林大成

